

**Robinsons**  
ALUMINIUM GREENHOUSES

# Victorian 'ROEMOOR' 15 Assembly Instructions

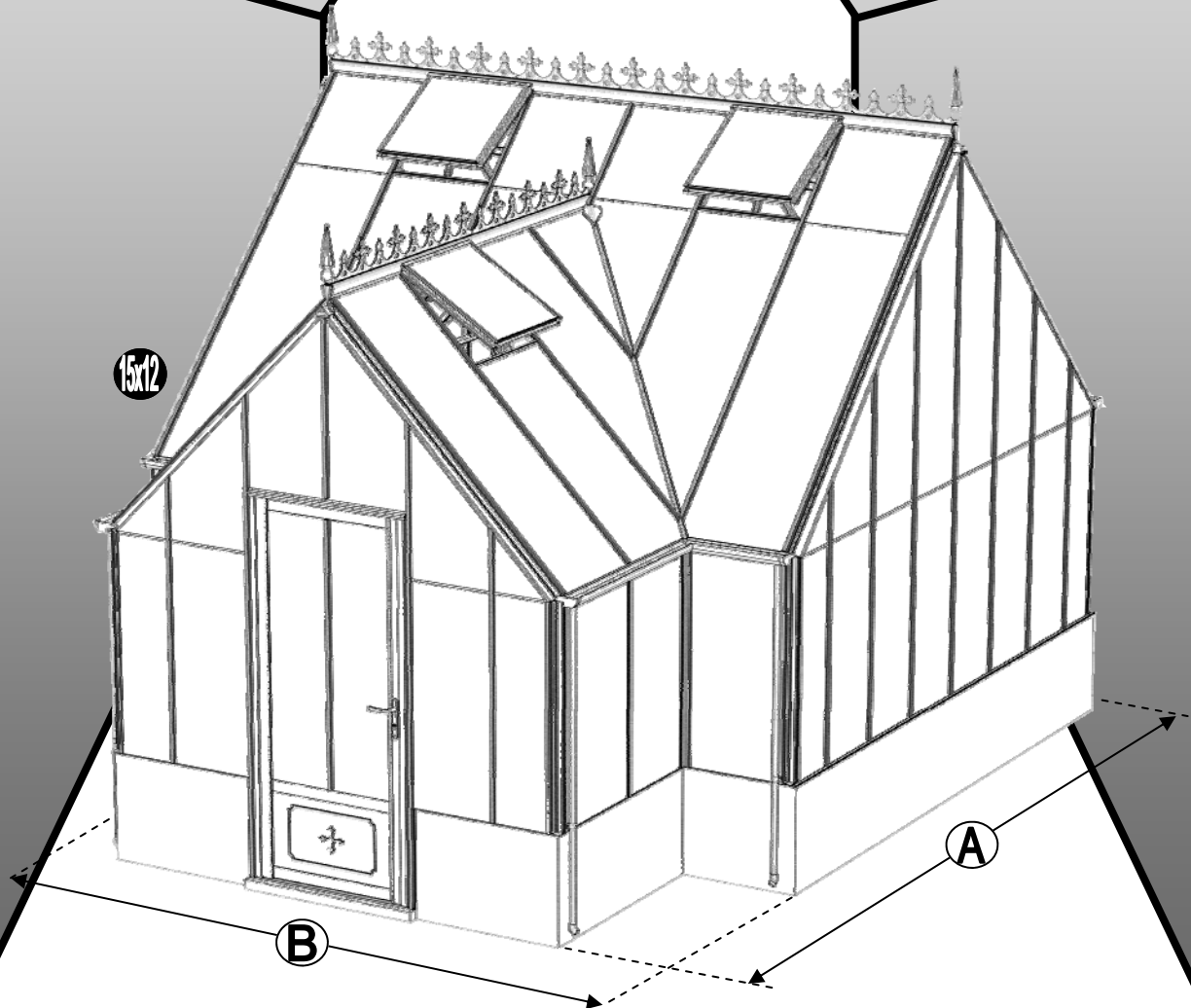

NOMINAL SIZE	A (mm)	B (mm)
15 x 12	4765	3870
15 x 20		6350
15 x 28		8830
15 x 36		11310

Issue 1.2



Thank you for purchasing your new Robinsons greenhouse. We recommend you familiarise yourself with the instructions and read all safety information before you commence assembly. This instruction manual is also available online at [www.robinsonsgreenhouses.co.uk](http://www.robinsonsgreenhouses.co.uk) in our technical help section should you need to reprint it. Should you require any additional advice you can always call us on 01782 385409.

These instructions are divided into sections highlighted by a white number/letter on a black background at the bottom corner of most pages (see opposite page for details); **part lists**, **B**-base, **P**-preparation, **1**-rear, **2**-porch gable, **3**-end gables, **4**-porch sides, **5**-main frame assembly, **6a**-rear roof, **6b**-porch roof, **7**-vent, **8**-louvre, **9**-glazing, **10**-vent attachment, **11**-door attachment, **12** anchoring down, **13** finishing touches, **14** optional shelf, **15** optional staging. If you need to contact us for assistance please refer to the relevant section/s. If your building is longer than 12', i.e. has an extension then please also refer the separate extension manual before you begin construction.

**Safety Warning**

- Glass and aluminium can potentially cause injury. Please ensure you wear protective goggles, gloves, headgear and suitable footwear when assembling and glazing the building.
- Please remember that glass is fragile and should be handled with extreme care. Always clear up and dispose of any breakages immediately.
- Do not assemble the greenhouse in high winds.
- For safety reasons and ease of assembly, we recommend that this greenhouse is assembled by a minimum of two people.
- Please clear all lying snow from the greenhouse roof as it can cause the roof to buckle or collapse.

**Site Preparation**

- When selecting a site for your greenhouse, it is vital that you choose as flat and level an area as possible.
- A concrete or slabbed base will provide the most solid foundation for your greenhouse.
- **IMPORTANT:** Do **not** fix your building down until the building is fully assembled, including glazing.
- Avoid placing your greenhouse under trees or in other vulnerable locations.
- To minimise the risk of wind damage, try to select as sheltered a site as possible, e.g. beside a hedgerow or garden fence.

**Additional Considerations**

- Please bear in mind that assembling your greenhouse can be time consuming. You may need to spread the construction over two or more days. We recommend that you avoid leaving the building partially glazed. If you ever have to leave your greenhouse half assembled and not anchored down, weigh it down with slabs or bags of sand to stop the wind moving it.
- You will find it helpful to prepare a large, clean and clear area in which to work in. A garage floor or flat lawn area is ideal.
- If you have arranged for someone to install your greenhouse for you, please check that all components are included. Some parts are numbered and can be identified by a stamped or hand written number (without the 'D'). Alternatively, the components can be identified by their distinctive profiles, lengths and quantities detailed in the parts list (see next page).
- Anchoring down your greenhouse should be the final stage of construction (including glazing).
- Once installed your greenhouse requires little maintenance, but to maintain the smooth running of your door(s) WD40 or similar can be applied to the door pivot pins / lock etc...

**Guarantee**

- Your new Robinsons greenhouse is guaranteed for 10 years against faulty manufacture of the frame-work. This does not include glazing, moving parts, accidental damage or wind damage.

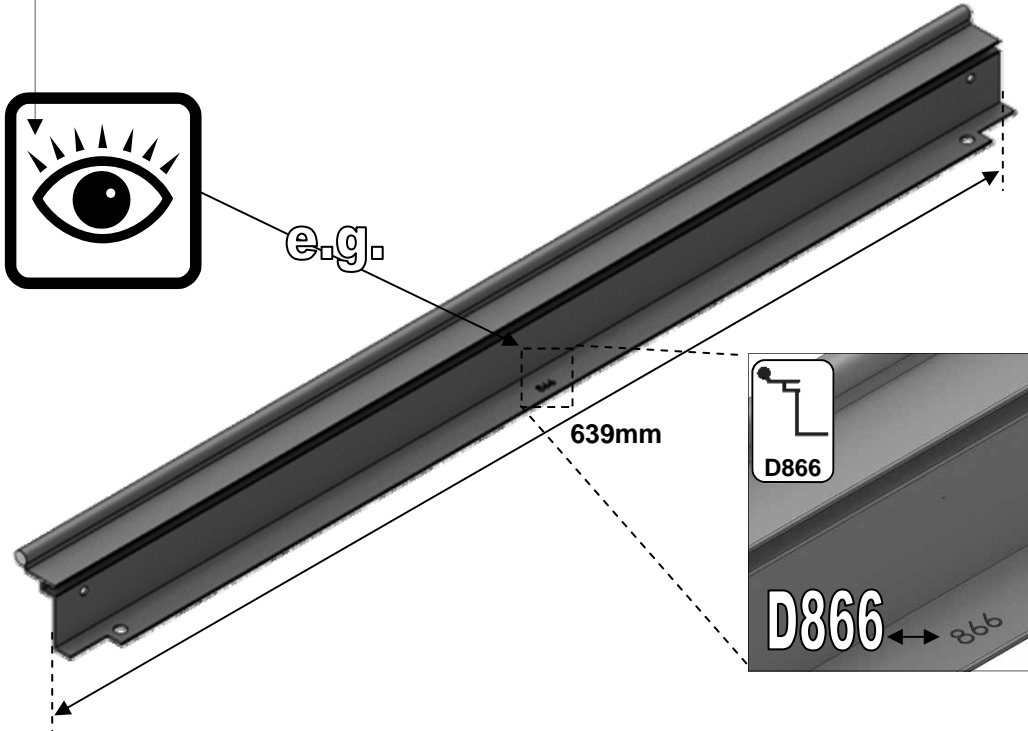







KEY SYMBOL	KEY DESCRIPTION
	EXTERNAL VIEW
	INTERNAL VIEW
	THINK
	THIS SECTION RELATES TO ANOTHER (e.g. 1 to 5)
	CORRECT
	DO <b>NOT</b> FIX DOWN!
	TWIST TO LOCK
	TIGHTEN
	PUSH AND HOLD
	CUT TO LENGTH











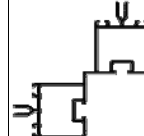

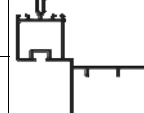

SECTION No	TITLE	ASSEMBLY SYNOPSIS: IMPORTANT INFORMATION / CONSIDERATIONS
B P 1 2/ 3 4 5 6a 6b 7a 7b 8 9 10 11 12 13 14 15	PARTS LIST	Most components should have a 'D' code punched into their metal surface. Identify and separate all like for like components prior to assembly. The 'parts list' also separates parts into the various sections 1 - 13 shown below. Parts can also be identified by their profile pictures and stated lengths etc..
	BASE	Base dimensions and recommendations. Ensure that your base is level as this will make assembly of the building, especially the glazing of the roof much more straight forward. Please be aware that the hinge door on your greenhouse opens inwards, make sure that there will be no interference between the door and the foundations.
	PREPARATION	Tools required. <b>IMPORTANT:</b> Use WD40 or similar in the glazing bar channels and insert the black glazing rubber prior to frame assembly.
	REAR	Take the glazing bars 'D609' with the rubber inserted and the diagonal braces 'D604', use 10mm bolts to join them to the gutter and 15mm bolts to the cills (note how the head of the bolt slides into each glazing bar during construction). Please also remember to slide in your 22mm bolts for attaching the decorative eave spandrels 'DV100' in section 6.
	PORCH GABLE	Again ensuring that the gable framework is rubbered-up follow the diagrams to assemble each gable in the building. Make sure that you have inserted the extra bolts utilised in sections 4 and 5. On the roof and side corner bars not every rubber channel will require rubber unless it is to be utilised in a partition (see separate manual and section P).
	END GABLES	
	PORCH SIDES	The porch sides (the L-shaped area to the left and right of the porch gable between cills and gutters level) can either be built in situ piece by piece or built away from the structure as an L-shape and then attached in a similar manner to plain gable/s to rear. Please ensure that where relevant you slide 2 x 22mm bolts into the side bars for the attachment of the DV100 eaves spandrels.
	MAIN FRAME ASSEMBLY	Take the rear (1) and the end gables (3) and join them together on your base. It is a good idea to tie some ladders to the sides to support them if you do not have anyone to hold them for you. Once the porch sides (4) have been attached to the main building then the porch gable (2) can be inserted between them in the same way you would attach a end gable to the rear. You will now have a T-shaped framework. It is important that you check that the internal diagonal measurements within the building are equal to ensure that the building is square, spending a little time on this now will speed up roof assembly and glazing. On buildings longer than 12' the end gable (1) should attach to the extension sides (see separate manual) first before the rear maintaining 620mm spacings, e.g. a 20' building = end (3), 4' handed extension sides, 12' rear (1), 4' handed extension sides, end (3).
	REAR ROOF	Attach the main ridge between the end gables and then the rubbered-up roof bars 'DV255' ensuring that they are fully butted up to the ridge and down onto the gutter. Attach your cresting before you glaze the building to give yourself more room to work. Utilise the 22mm bolts slid into the rear (section 1) and roof bars to attach your DV100 and DV101 spandrels. On longer models you may need to carefully prop up the roof and tie the sides together to keep the ridge and gutters straight (i.e. not sagging or bowed) until the building is fully glazed.
	PORCH ROOF	The porch ridge can be fitted to the porch gable supporting its free end with ladders or a wooden sprag. The porch hips 'DV379' can now be attached between the welded porch gutter sections and the free end of the porch ridge. A 'lower' height porch utilises a DV380 bracket to allow the porch ridge to connect to the main module. Identify all of the handed roof bars and look for their locations. Insert the rubber into their channels and when attaching ensure again that where relevant you slide in 22mm bolts for eave (x2) and roof spandrels (x2). Eave and Roof spandrels can now be attached using the previously inserted 22mm bolts. The ladders / sprag supporting the porch ridge free end can now be removed.  Prior to glazing the cresting and finials should be siliconed into place. Attaching them once the glass has been installed by leaning through vent apertures is more time consuming.
	VENT	Once the vent is glazed add silicone to the vent sides and top. Stand the vent/s on their hinge (vent top) and then leave the silicone to set.
	VENT SLAM	The slam bar 'D079' can be moved up and down between the roof glazing bars so that it can be butted down onto the pane of glass beneath, the autovent will be attached to it later on (10).
	LOUVRE	They attach to the building during the glazing process (9) like a piece of glass with a black separator above them. If you are fitting an optional auto-louvre then you need to carefully drill (3mm bit) out the rivets which mount the handle to the frame. You can then either utilise those holes or create more to mount the unit.
	GLAZING	Layout the bar cappings and covers around the building like a sundial checking that all is present and correct. You can also place the roof cappings in the gutters so they are closer to hand. Use the capping and the self tapping screws to then hold the glass in place. The covers then enclose the screw heads giving a neat finish. It is a good idea to glaze two roof sections first to ensure the building is square followed by two side sections to ensure the building isn't leaning. We would then recommend that you glaze the porch roof and its adjoining angled roof panes whilst the building still has some movement in it.  The porch cowl 'DV341' should be attached before the vents are inserted so that access through vent apertures is available. Silicone the cowl area internally, position cowl and VERY carefully (avoiding glass below) mark, drill and screw x 2 'FS6018' into place. <b>IMPORTANT:</b> Silicone the cowl externally and check with watering can that the cowl is water tight, note silicone can be moulded shortly after application if you wet your fingers.  <b>IMPORTANT:</b> On the roof sections please make sure that you place a screw around 25mm / 1" from the bottom of each capping strip (create a hole in the plastic if required) and that the screws are nice and tight to avoid any glass slippage.
	VENT ATTACHMENT	Take the assembled vent and slide the vent hinge 'D866' into the end of the ridge allowing the vent to pivot open and closed. Vent stops go either side of the vent to stop any lateral movement (so insert stop / vent / stop). Attach the Bayliss XL autovents.
DOOR ATTACHMENT	Your door comes pre-constructed and locked minus the handles and their pivot pin but now it needs to be mounted to the front end of your building. Utilise the 'DV522' plates and twist in crop headed bolts to join the door and its frame to the building (pinch the door frame against your long front verticals whilst tightening your 'DV522' plates to ensure that there is no gap). If you are struggling to eradicate the gap between the door frame and verticals then some silicone can be carefully applied to the area to create a vertical seal. Be careful not to lock yourself in the building and to avoid damage do not open the door until it is attached to the front gable. Getting the door to swing perfectly without dropping or rubbing on the ground may require some small but vital adjustments. You may also need to insert a packer underneath the door frame hinge to increase ground clearance. Part 'DV275' canopies the door frame top hiding the clearance space at the top of the door. The door can only be made to swing inwards.  <b>IMPORTANT:</b> Please do NOT let the door slam open or closed as it is likely to cause damage to the door and the frame. Please twist the handle to open and close. Please also be aware that your door KEYS (3 provided) are unique to the building so they should not be stored together.	
ANCHORING DOWN	Now that the greenhouse is finished and the door and vent/s are operating without interference then you need to anchor the building down using 2" rawl plugs and screws. Use a 7mm masonry bit in a hammer drill to create the holes.	
FINISHING TOUCHES	Now that the main body of the structure is complete you can add; downpipe fittings, eave bungs, gutter stop ends. It is also important to carefully apply some silicone to the internal eaves corners and external and internal ridge corners to minimise the chance of water entering the structure.	
OPTIONAL REAR SHELIVING	Robinsons integral cantilever staging and shelving attaches to the inside of the greenhouse frame using either square head bolts (insert four into each side glazing bar 'D609' during construction of the rear (1)) or rectangular 'crop head' bolts which can be fitted retrospectively (both sets of bolts accompany the shelving/staging). This system allows the height of either the staging or the shelf to be set at an operator specific height. Commonly the staging brackets are set 900mm from the cills though you can alter this to suit the end user/s. The aluminium shelf / staging slats come in two lengths; (4'):1240mm 'D2002' and (6'):1860mm 'D2003'. These slats can combine to create any length of staging required, i.e. 4'+6' = 10' etc...	
OPTIONAL REAR STAGING		

# Victorian Roemoor

Section Ref	Part No.	Section	Size (mm)	15	12
-------------	----------	---------	-----------	----	----







<b>1</b>	D023		3754	1	
	DV212		3757	1	
	D604		1316	2	
	D609		1160	5	
	RUBBER		1000 (1m)	12	
	D174		N/A	3	

<b>2</b>	DV302L		852	1	
	DV302R			1	
	D608		1160	2	
	DV066L		1505	1	
	DV066R			1	
	DV237L		2489	1	
	DV237R			1	
	DV270L		782	1	
	DV270R			1	
	DV307		1350	2	
	DV251L		1790	1	
	DV251R			1	
	DV263		930	1	
	DV275		904	1	
	D163		90	2	
	DV104		N/A	2	
	DV105		N/A	1	
	RUBBER		1000 (1m)	27	
	D174		N/A	4	











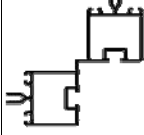





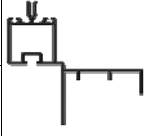

MAIN FRAME  
QUANTITIES

VENTS / DOORS etc  
SEPERATE

Part No.	15	12
SYBOL M6X11		
10mm		157
SYBOL M6X11 CROP		
10mm		20
SYBOL M6X15		
15mm		46
SYBOL M6X22		
22mm		60
SYNUTM6		
M6 NUT		291
FS6018		
19mm		2

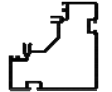
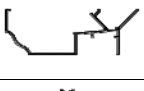
Section Ref	Part No.	Section	Size (mm)	15	12
-------------	----------	---------	-----------	----	----

<b>3</b>	DV232		3548	2	
	D608		1160	4	
	DV066L		1505	2	
	DV066R			2	
	DV310L		1972	2	
	DV310R			2	
	DV312L		2438	2	
	DV312R			2	
	DV259		2879	2	
	DV274		3402	2	
	DV307		1350	4	
	DV252L		2451	2	
	DV252R			2	
	DV104		N/A	4	
	DV105		N/A	2	
RUBBER		1000 (1m)	72		
D174		N/A	14		

<b>4</b>	DV358		608	1	
	DV359		1228	1	
	DV373		608	1	
	DV374		1228	1	
	DV363		1160	2	
	DV391		632 x 1252	1	
	DV392			1	
	D609		1160	2	
	RUBBER		1000 (1m)	10	
	D174		N/A	4	

Section Ref	Part No.	Section	Size (mm)	15 12
-------------	----------	---------	-----------	----------

<b>6</b>	D982		100	2
	DV100		N/A	7
	DV101		N/A	8
	DV203		3757	1
	DV351		2470	1
	DV254		1790	2
	DV255		2450	5
	DV365		899	1
	DV375L/R		830	1+1
	DV376L/R		1708	1+1
	DV377L/R		1492	1+1
	DV378L/R		2368	1+1
	DV380			N/A
	DV379		2212	2
	DV383		661	1
	RUBBER		1000 (1m)	60

<b>7</b>	D866		639	5
	D863L		613	5
	D863R		613	5
	D862		593	5
	D079 PLUS FLUFF		590	5
	D114		N/A	10
	D220 PLUS FS6060 SCREW		N/A	10
	D205		N/A	10

# Victorian Roemoor

Section Ref	Part No.	Section	Size (mm)	15 12
-------------	----------	---------	-----------	----------

<b>9</b>	1 / 4	D618		1144	11	
	6	D870		601	9	
	2 / 3	DV403L/R		1505	3 + 3	
	10	DV479		1384	1	
	3	DV610L/R		1972	2 + 2	
	3	DV612L/R		2438	2 + 2	
	2	DV637L/R		2489	1 + 1	
	6	DV654		1821	2	
	6	DV655		1880	5	
	3	DV659		2879	2	
	2 / 10	DV663		905	1	
	6	DV675L/R		863	1 + 1	
	6	DV676L/R		1741	1 + 1	
	6	DV677L/R		924	1 + 1	
	6	DV678L/R		1799	1 + 1	
	6	DV683		680	1	
	2 / 3	D610			1160	6
	1 / 4	D620			1144	6
	6	D871			601	4
6	DV651	1790	2			
6	DV652	1871	4			
2 / 3	D614		1162	6		
1 / 4	D619		1144	17		
10	DV480		1384	1		
3	DV611L/R		1972	2 + 2		
3	DV613L/R		2438	2 + 2		
2 / 3	DV615L/R		1505	3 + 3		
2	DV638L/R		2489	1 + 1		
6	DV657		1821	4		
6	DV658		2481	9		
3	DV665		2879	2		
2	DV669		905	1		
6	DV679L/R		863	1+1		
6	DV680L/R		1741	1+1		
6	DV681L/R	1525	1+1			
6	DV682L/R	2400	1+1			
6	DV684	680	1			
6	DV341		N/A	1		

<b>11</b>	D522		N/A	10
-----------	------	--	-----	----

<b>13</b>	D119		1	
	DV120		N/A	6
	D841		N/A	6
	D211	PIPE	1625	6
	D207		N/A	6
	D201		N/A	6
	D208		N/A	3
	DV219		N/A	3
	DV218		N/A	3

**B**

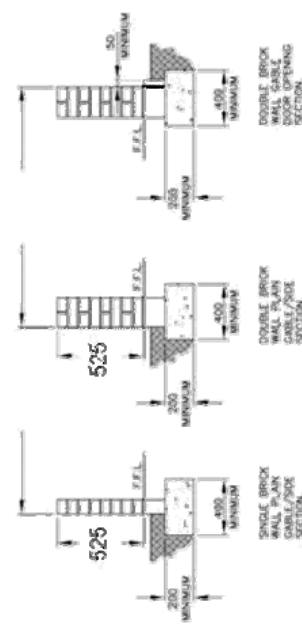
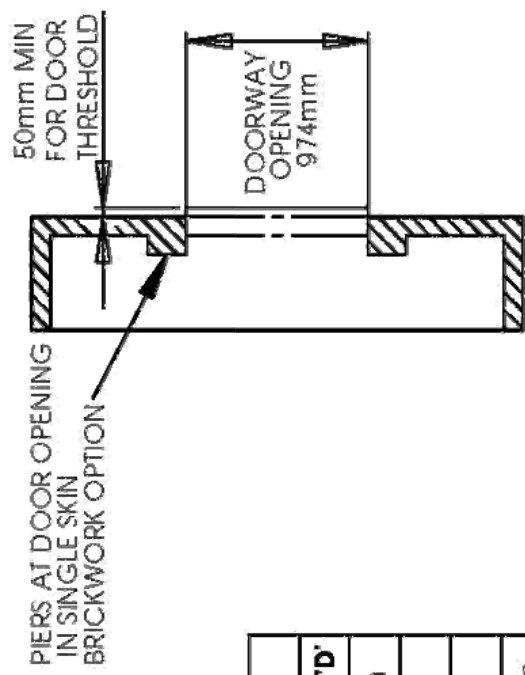
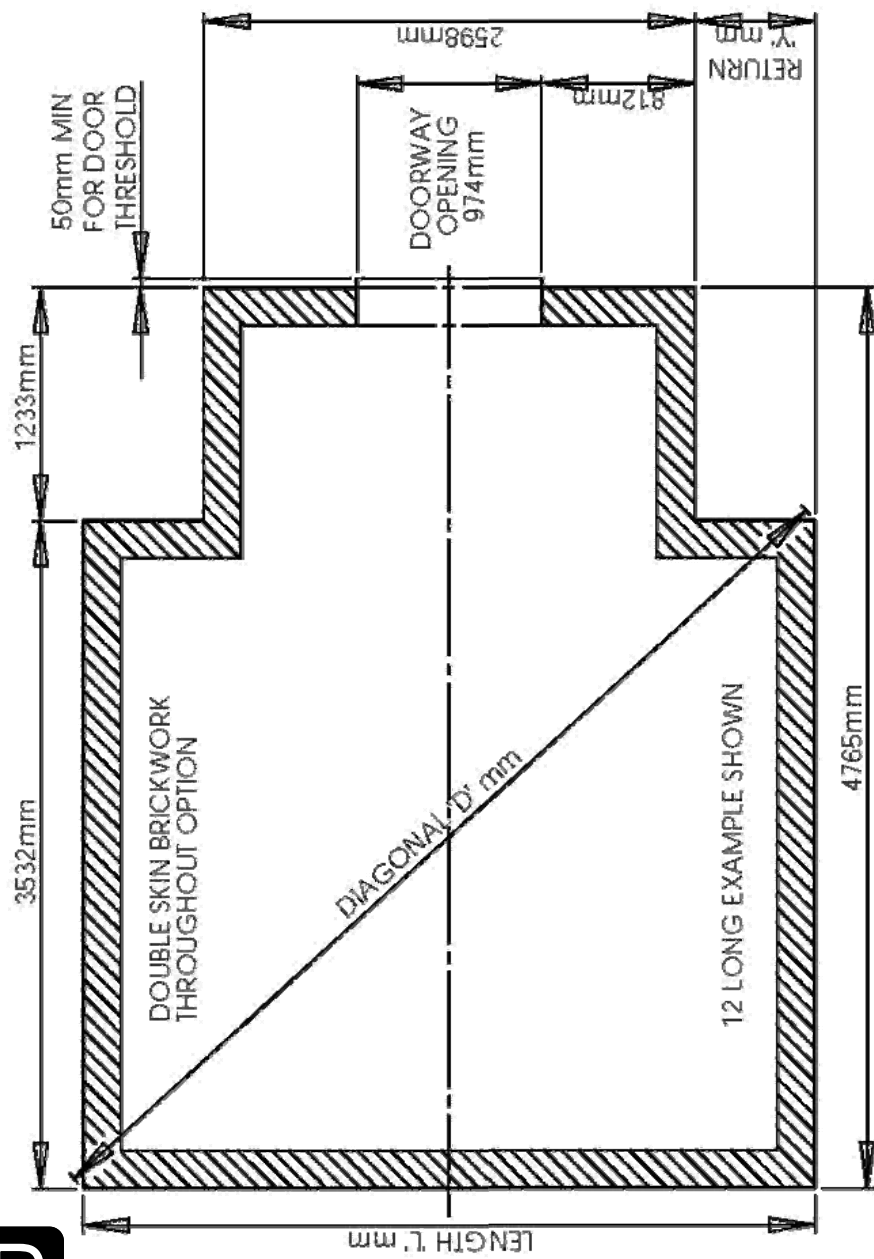

**GUIDANCE NOTE FOR ROBINSONS DWARF WALL GREENHOUSES. FOOTINGS**  
 CONCRETE STRIP FOOTINGS SHOULD BE A MINIMUM OF 400mm WIDE X 200mm DEEP. IF THE SITE IS ON MADE UP GROUND IT IS IMPORTANT THAT THE FOOTINGS ARE CUT INTO THE COMPACTED GROUND BELOW WHERE THE GROUND IS LIABLE TO MOVEMENT SUCH AS HEAVY CLAY OR LOOSE SANDY SOIL REINFORCING SHOULD BE ADDED TO THE CONCRETE FOOTINGS.

**WALLS**  
 IT IS MOST IMPORTANT THAT THE BRICKWORK IS IN ACCORDANCE WITH THE 'mm' DIMENSIONS PROVIDED AND IS SQUARE, LEVEL AND UPRIGHT. THE DIAGONAL MEASUREMENTS SHOULD BE EQUAL. WALLS CAN BE EITHER DOUBLE OR SINGLE SKIN.

THE TOP COURSE OF BRICKS SHOULD BE LAID FROG DOWN. IF ENGINEERING BRICKS ARE USED FOR THE TOP COURSE PLEASE ENSURE THEY ARE SOLID NOT CELLULAR (WITH HOLES THROUGH THEM) OR FIXING DOWN OF THE GREENHOUSE WILL BE A PROBLEM. BRICKS SHOULD BE A GOOD QUALITY STOCK BRICK, SAND FACED FLETTON TYPE BRICKS ARE NOT SUITABLE.

**GABLE DOOR OPENING**  
 THE DOOR THRESHOLD REQUIRES BRICK WORK ACROSS THE OPENING WHICH SHOULD BE LEVEL WITH THE FINISHED FLOOR LEVEL (F.F.L) OF THE GREENHOUSE. THE OPENING FOR THE DOORWAY AND THE HEIGHT TO THE TOP OF THE WALL FROM THE THRESHOLD LEVEL REQUIRE THE HIGHEST ACCURACY AND ARE MOST IMPORTANT SO THAT THE DOOR FITS THE APERTURE CORRECTLY. PLEASE ALSO BE AWARE THAT THE DOOR OPENS INWARDS AND THEREFORE THE FOUNDATIONS NEED TO AVOID ANY DOOR INTERFERENCE. IT IS ADVISABLE TO MAKE A WOODEN TEMPLATE TO CHECK THE DOOR APERTURE DIMENSIONS.

IF SINGLE SKIN WALLS ARE USED THEN PIERS SHOULD BE FORMED AT THE DOOR OPENING.

IN ORDER TO SUPPORT THE OUTER EDGE OF THE DOOR THRESHOLD THERE MUST BE A PROJECTION OF BRICKWORK / CONCRETE IN FRONT OF THE DOOR END WALL WITH A MINIMUM WIDTH OF 50mm. THIS NEEDS TO BE LEVEL WITH THE DOOR THRESHOLD OPENING.

Property of Robinsons Greenhouses' © 2016



TITLE: **ROEMOOR WITH 2 BAY RUSHMOOR PORCH**

DIMENSION VARIABLES (mm)			
MODEL	LENGTH 'L'	RETURN 'Y'	DIAGONAL 'D'
12 LONG	3870mm	636mm	5239.5mm
20 LONG	6350mm	1876mm	7266mm
28 LONG	8830mm	3116mm	9510mm
36 LONG	11310mm	4356mm	11848.5mm

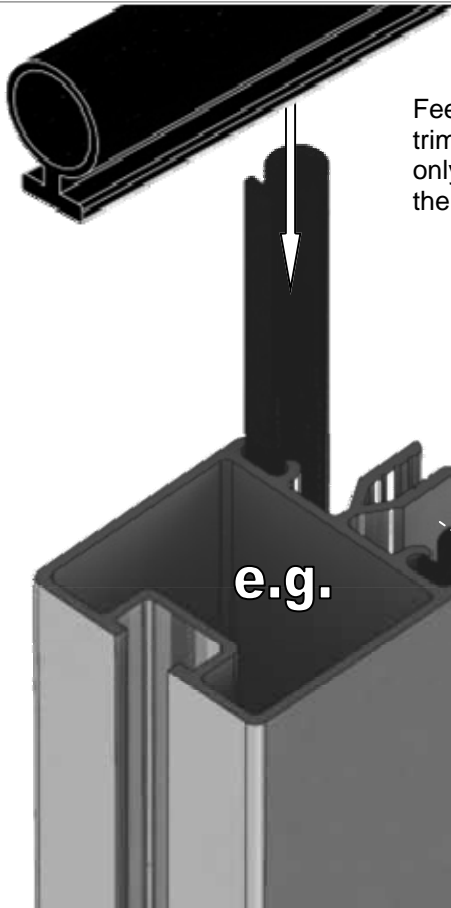

Feed glazing rubber into each glazing bar and trim to length. Notice that some channels are only used on a partition. Applying a lubricant to the aluminium channels will speed up insertion.

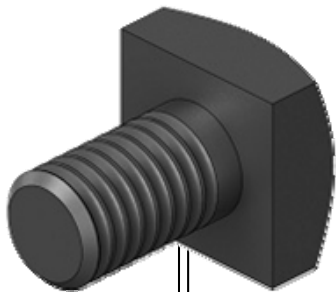
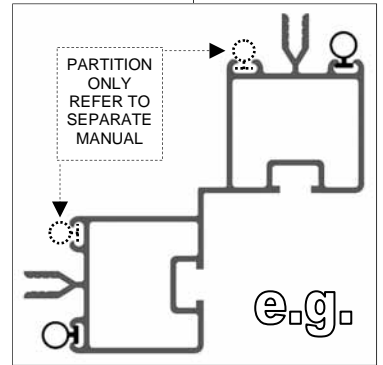
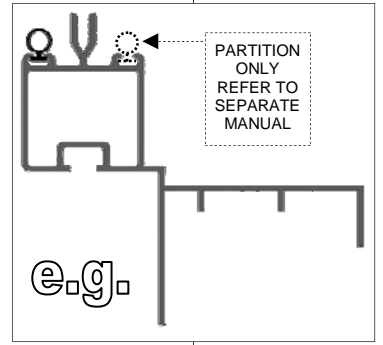
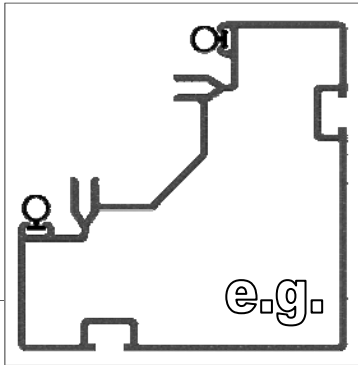
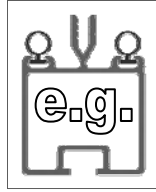

The frame is assembled by feeding square headed bolts, either 10mm, 15mm or 22mm in length into the slots on glazing bars and then locating those bolts through holes in purlings and cills, etc... Twist in (rectangular) crop headed bolts are also used towards the end of construction to attach components to the frame when the glazing bar slots are no longer exposed at the ends.

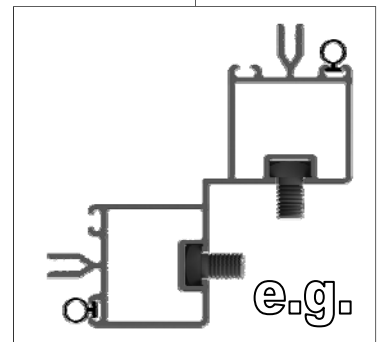
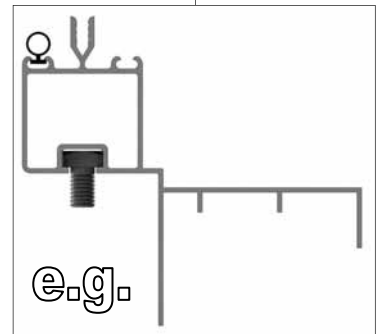
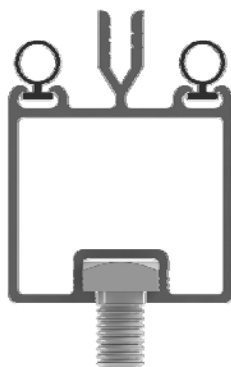
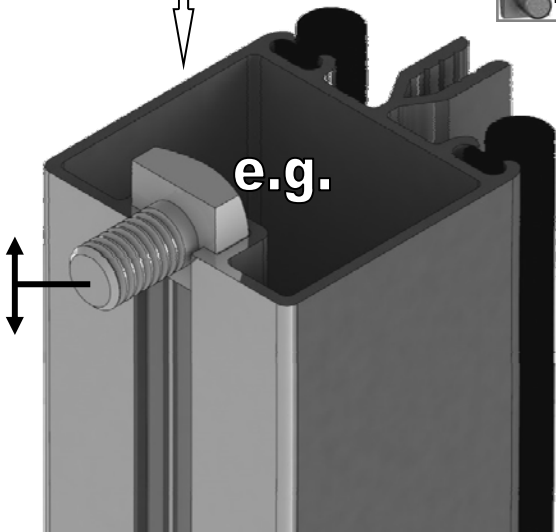

REAR		15 x 12
Part No	mm	Quantity
DV212	3757	1
D023	3754	1
D609	1160	5
D604	1316	2
D174		3
SYBOL M6X11		5
SYBOL M6X15		7
SYBOL M6X22		10
SYNUT M6		12
D227 Rubber	1000 	12

e.g. **15x12**

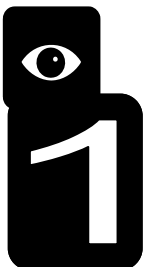
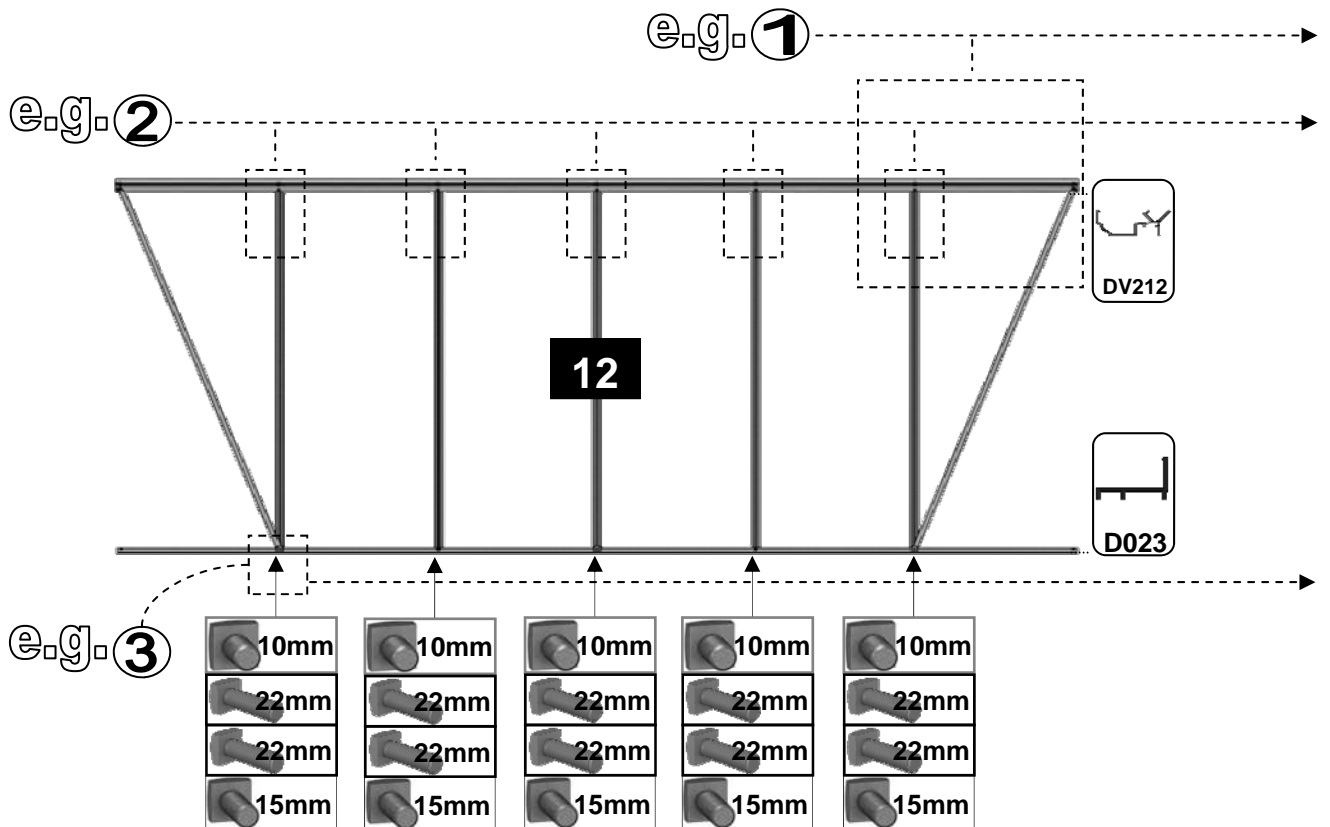
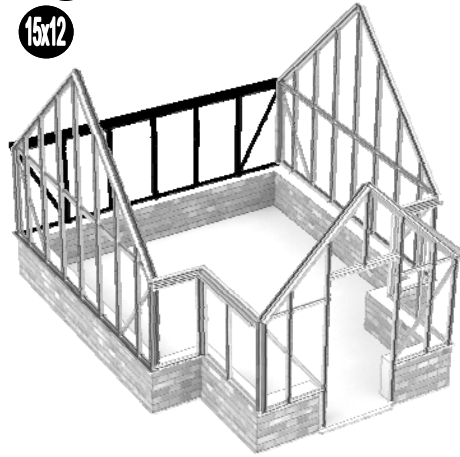



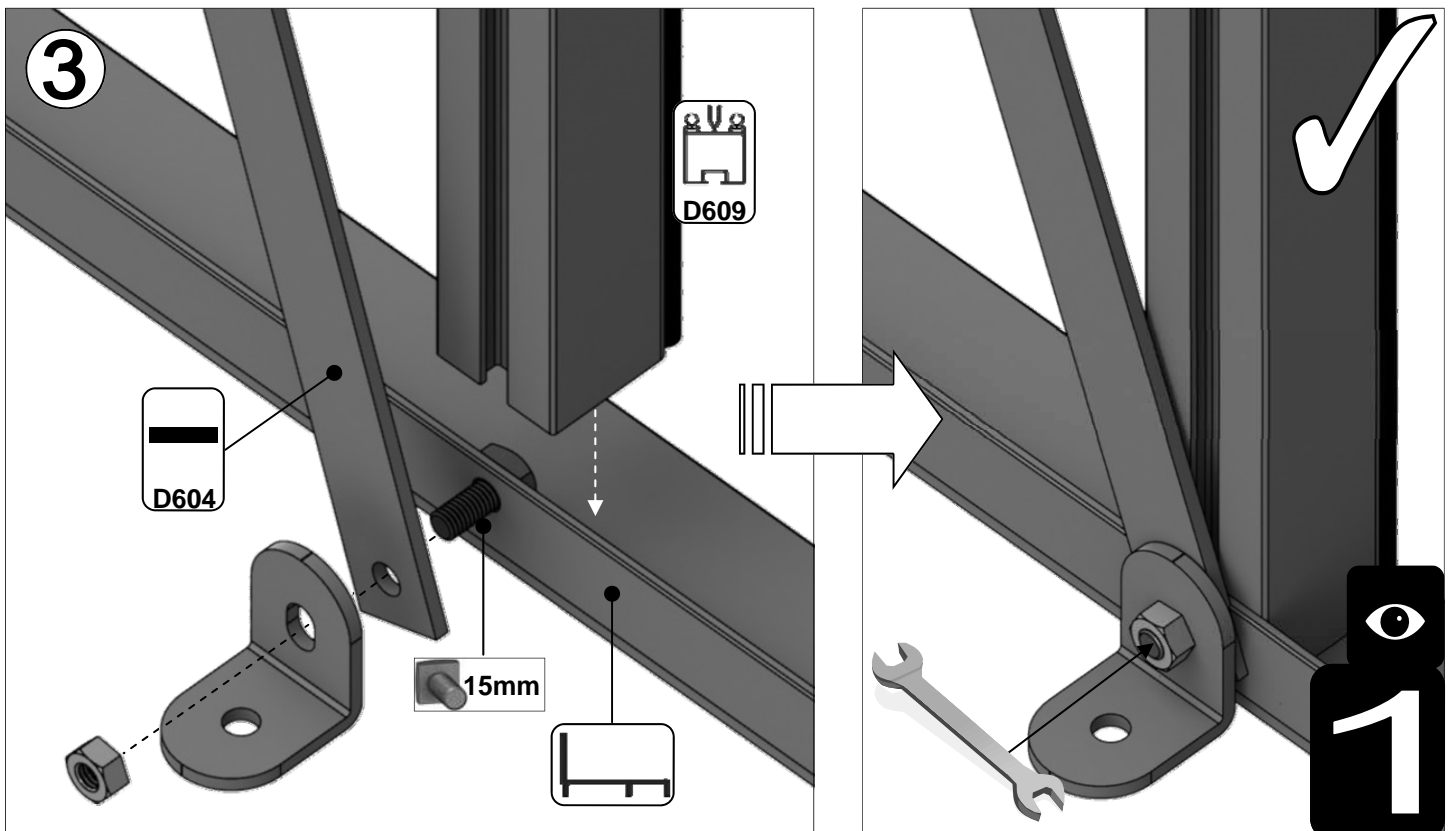
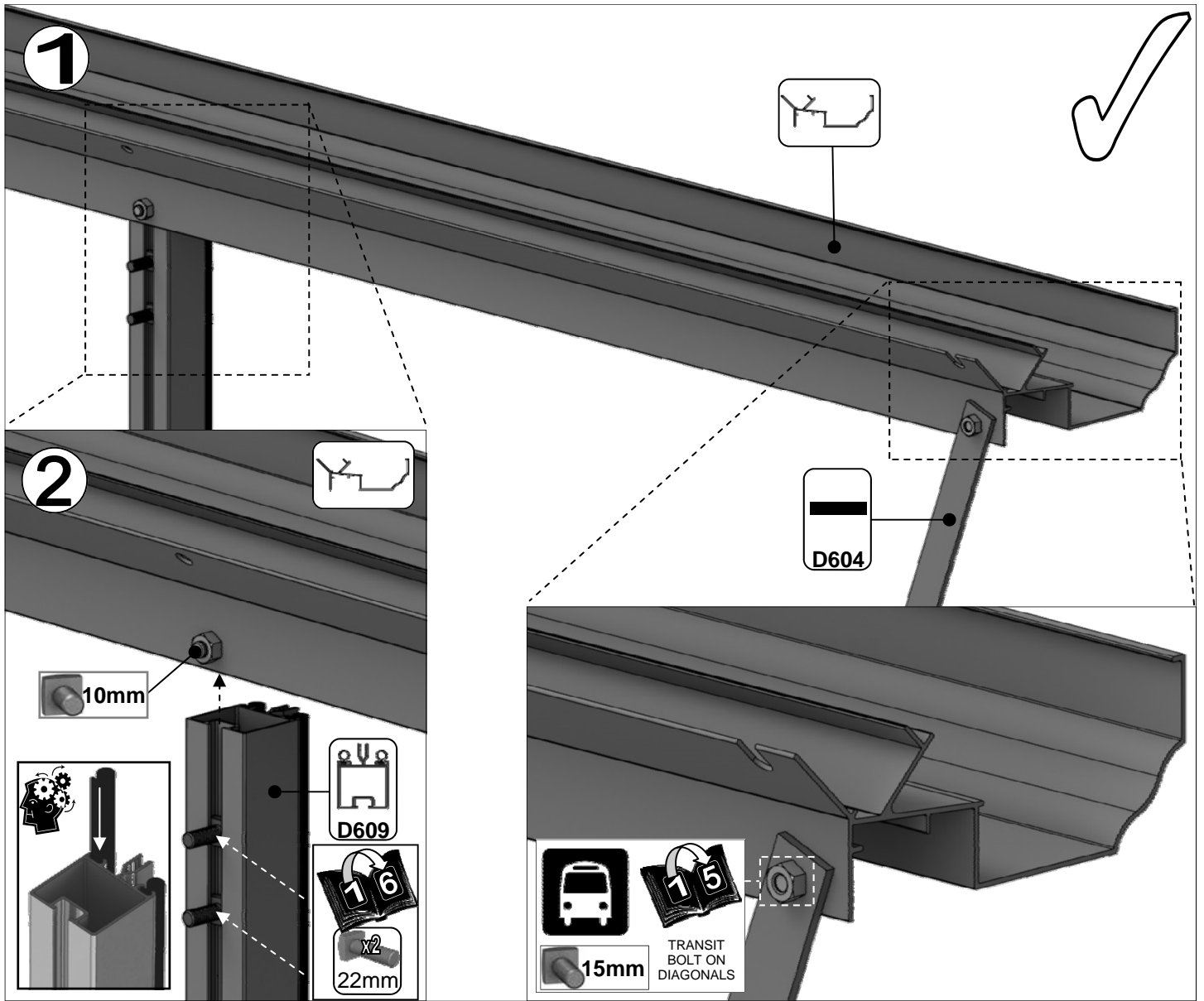

e.g.

15x12

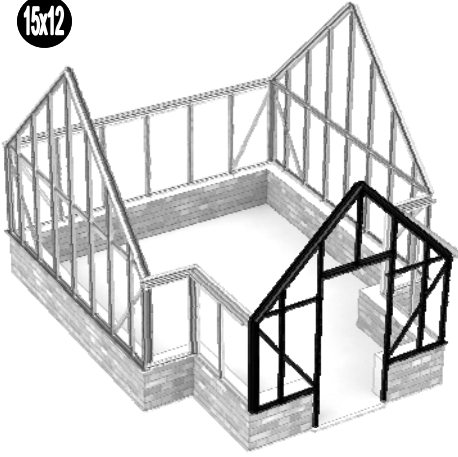

PORCH GABLE		
Part No	mm	Quantity
DV066L	1505	1
DV066R	1505	1
D608	1160	2
DV237L	2489	1
DV237R	2489	1
DV251L	1790	1
DV251R	1790	1
DV263	930	1
DV270L	782	1
DV270R	782	1

Part No	mm	Quantity
DV275	904	1
DV302L	852	1
DV302R	852	1
DV307	1350	2
DV104		2
DV105		1
D174		4
D163		2
D227		27m
M6X10		34
M6X15		10
M6NUT		44

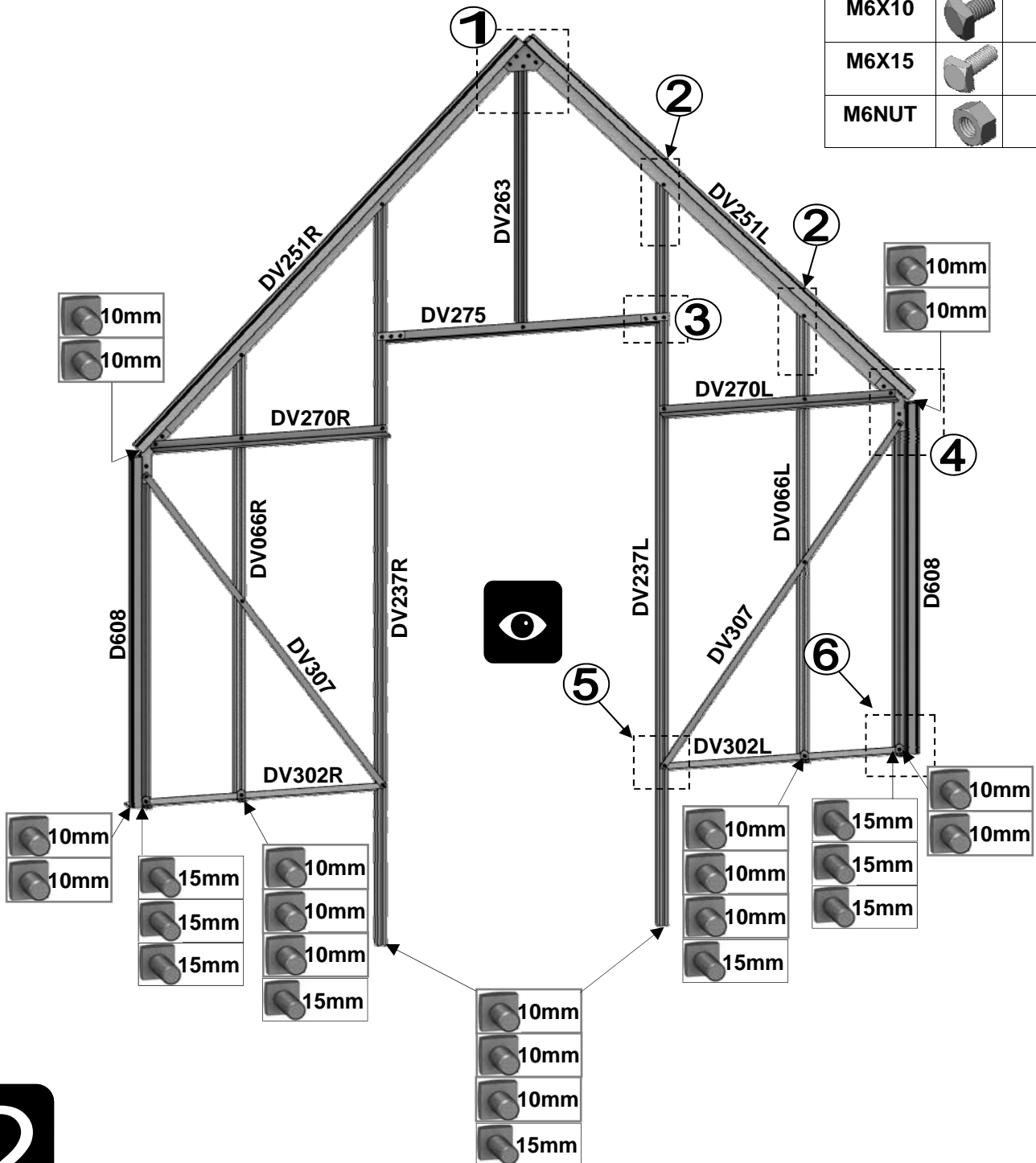

2

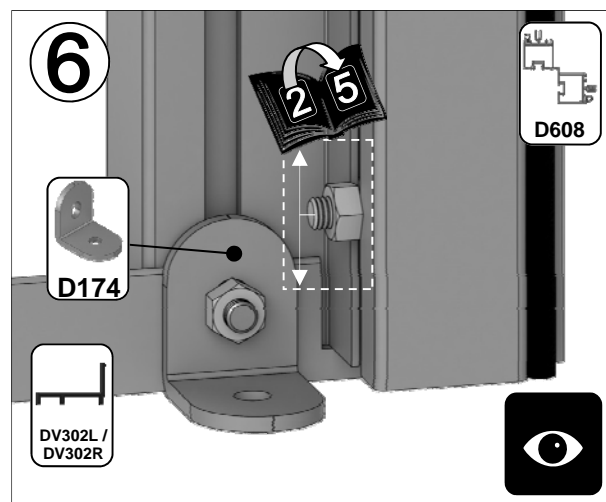
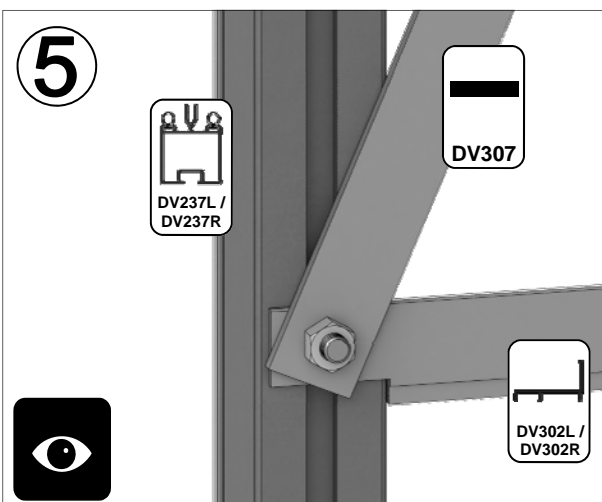
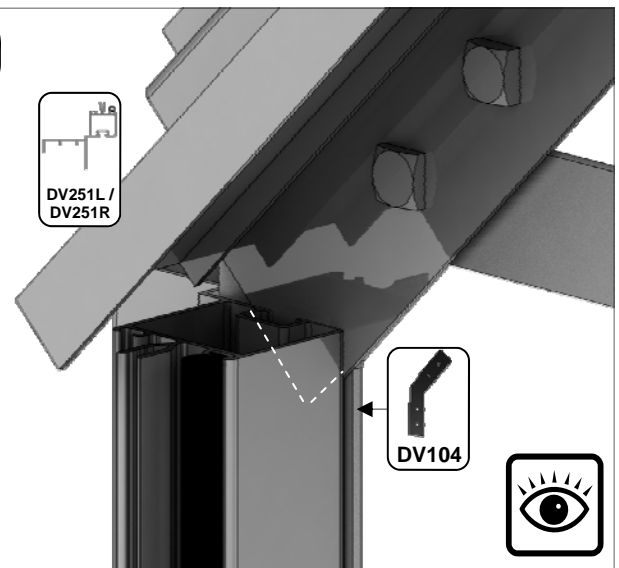
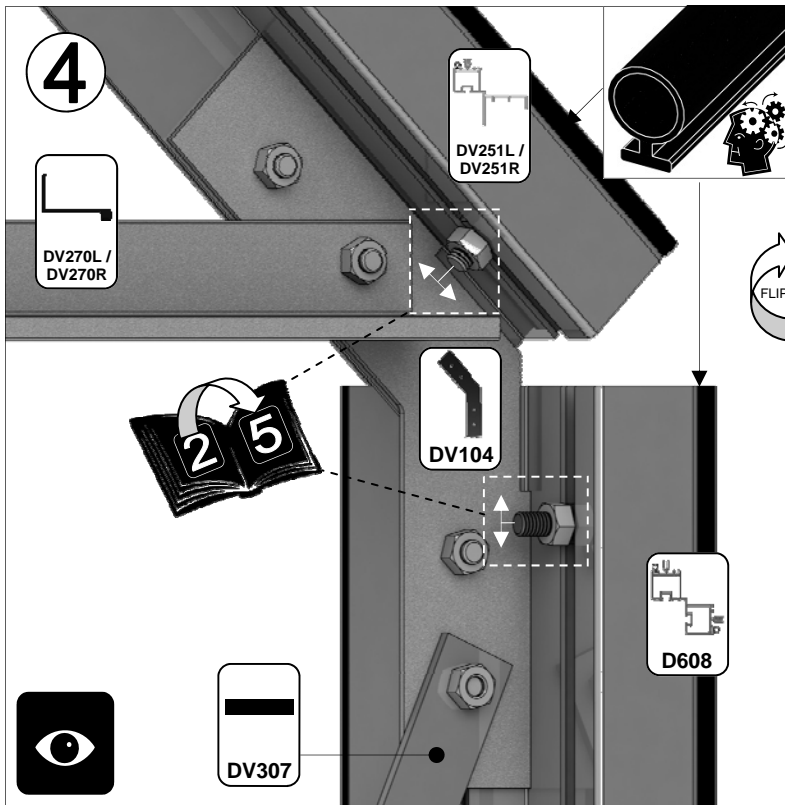
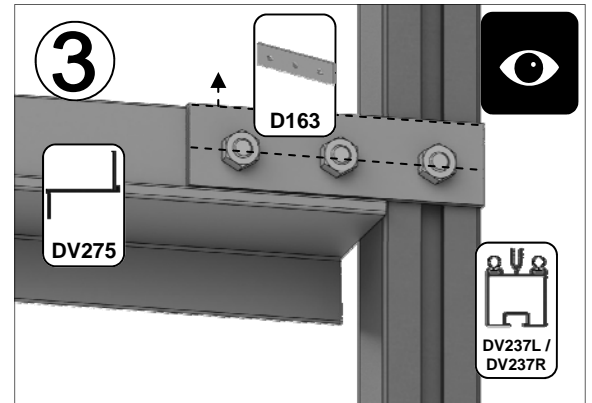
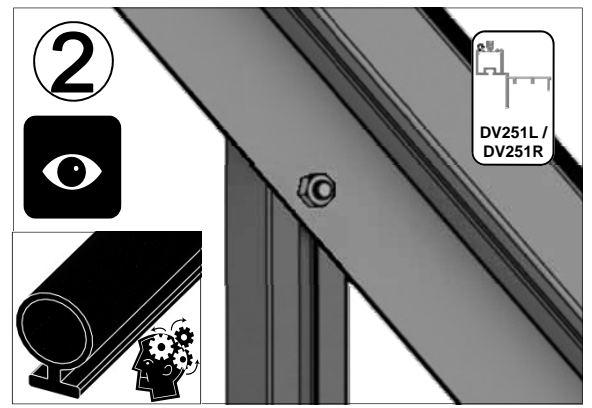
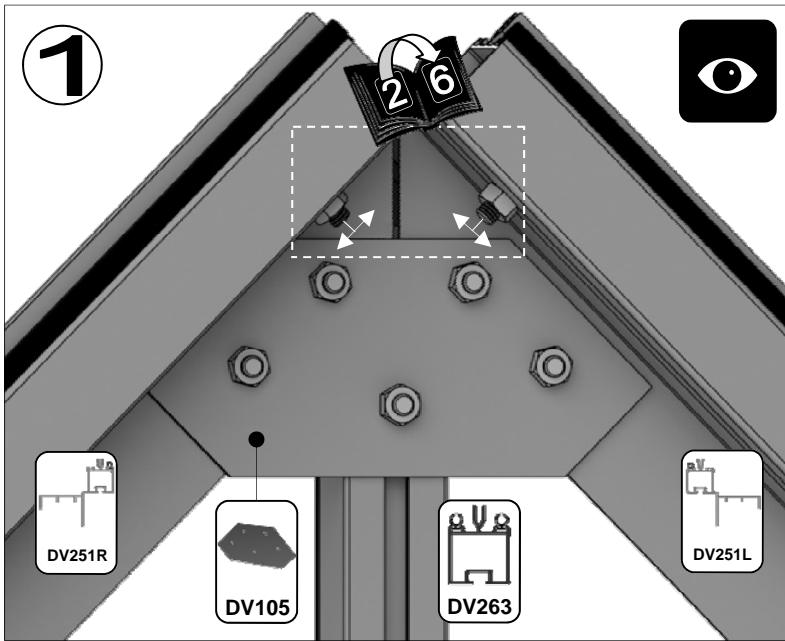

**2**

e.g.

15x12

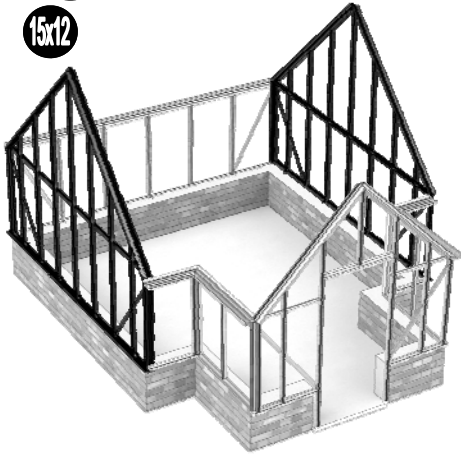

END GABLE X 2		
Part No	mm	Quantity
DV066L	1505	2
DV066R	1505	2
D608	1160	4
DV232	3548	2
DV252L	2451	2
DV252R	2451	2
DV259	2879	2
DV274	3402	2
DV307	1350	4
DV310L	1972	2
DV310R	1972	2
DV312L	2438	2
DV312R	2438	2

Part No	mm	Quantity
DV104		4
DV105		2
D174		14
D227		72m
M6X10		64
M6X15		26
M6NUT		90

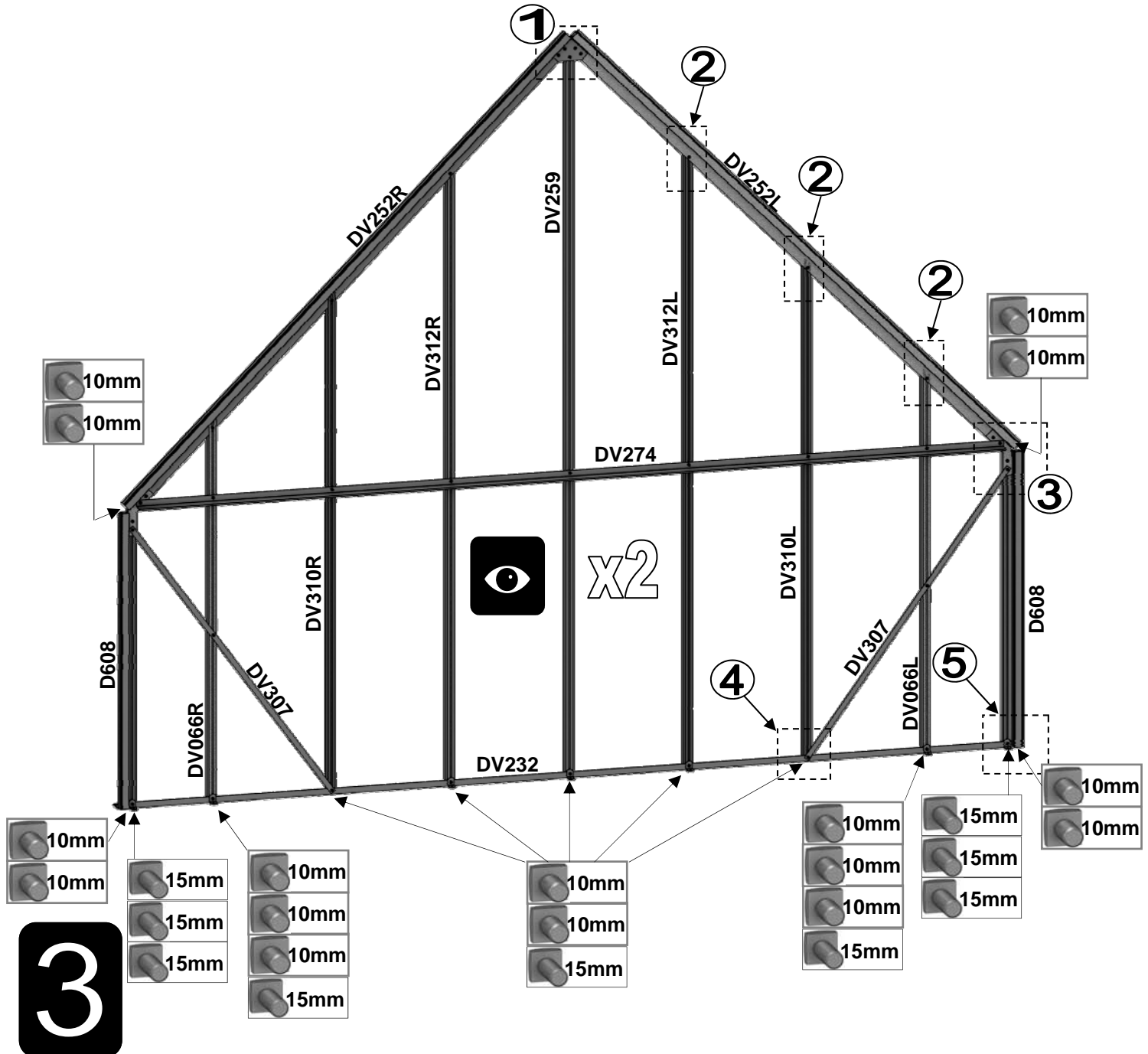

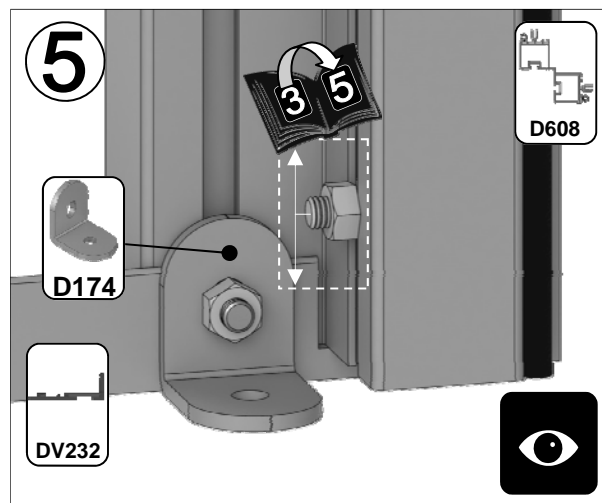
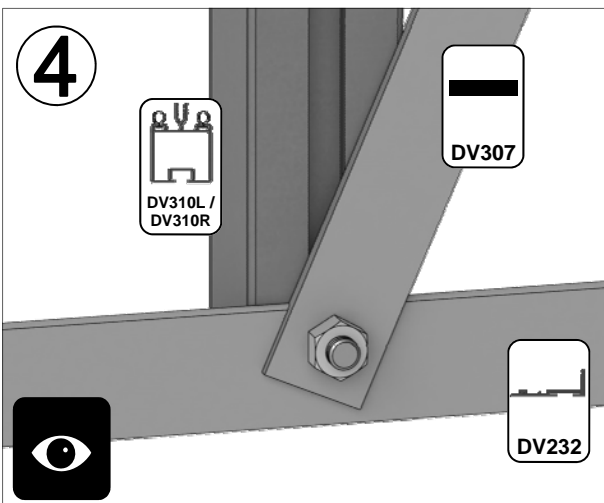
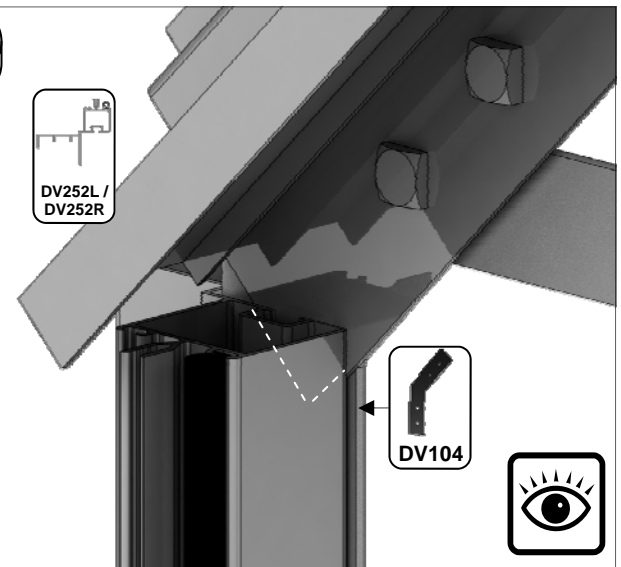
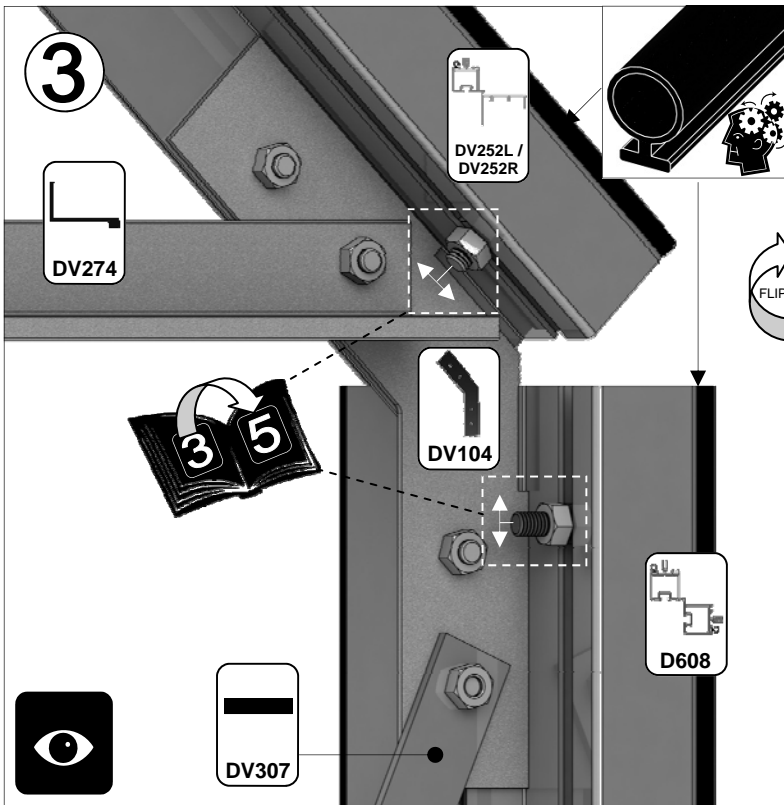
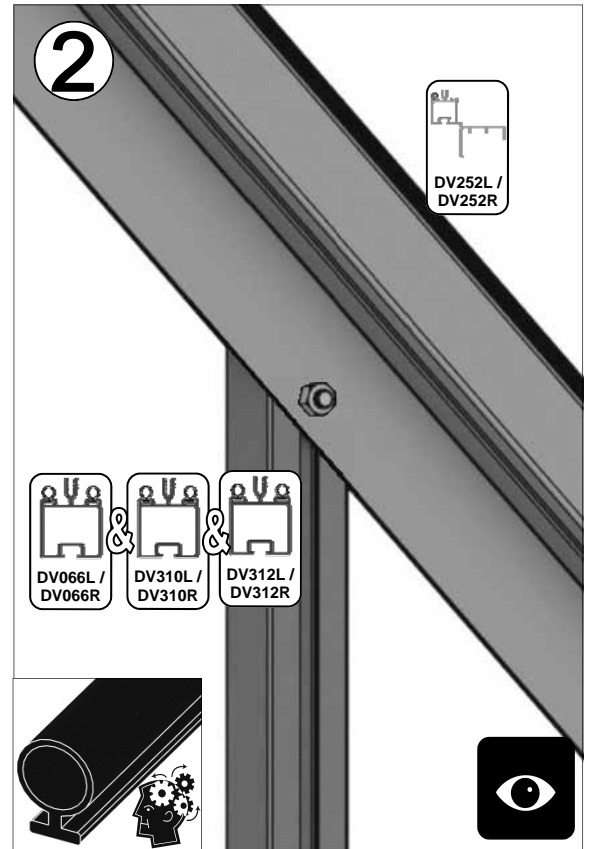
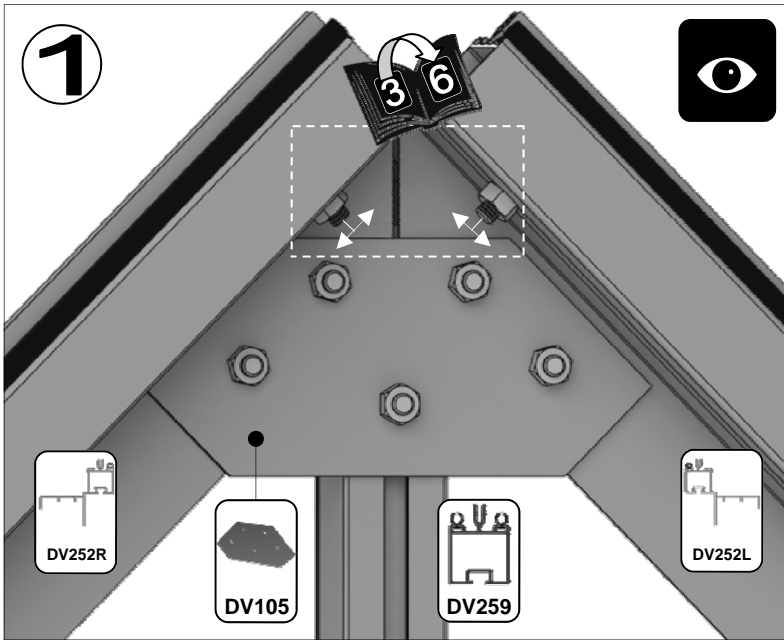

e.g.

15x12

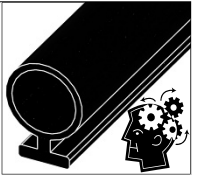
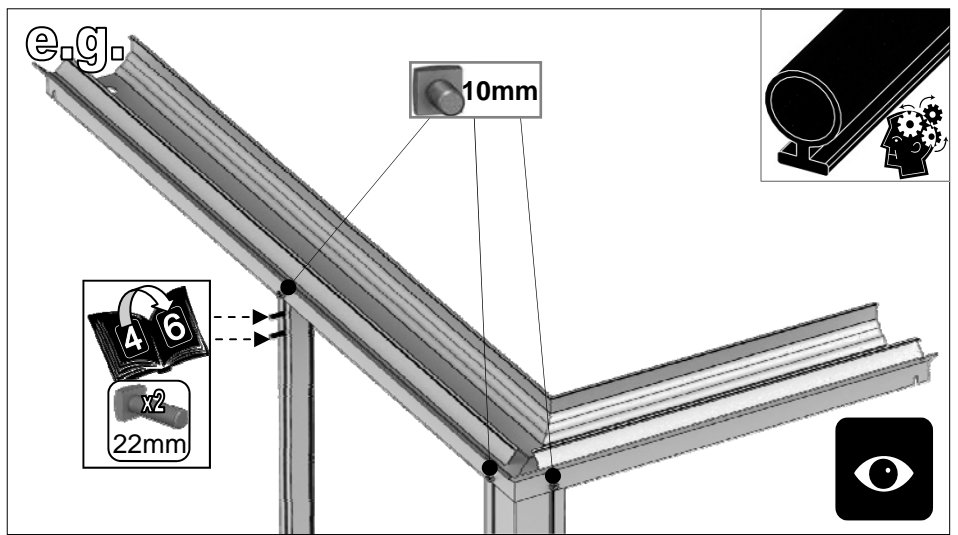
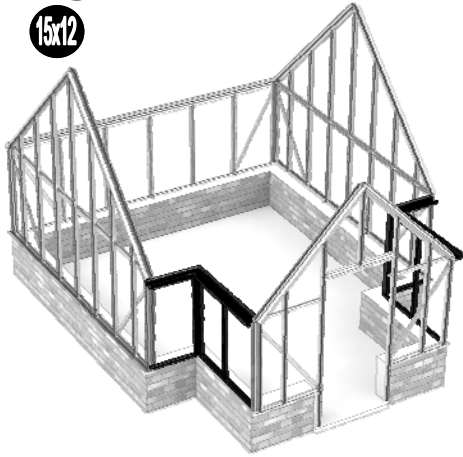

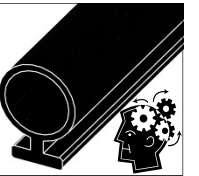
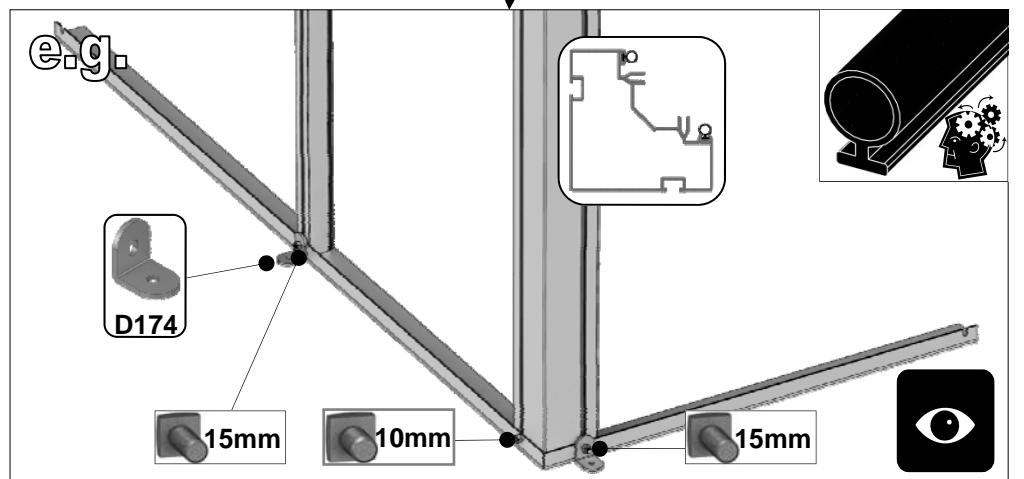
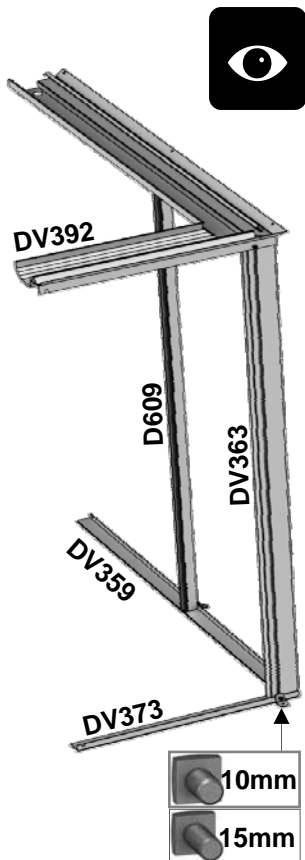
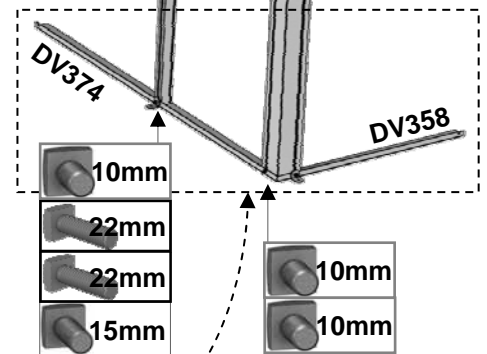
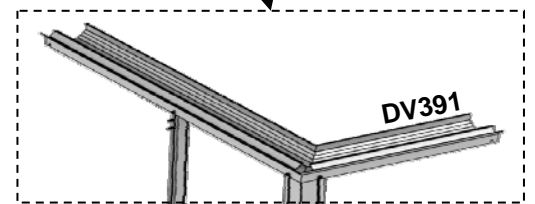

PORCH SIDES		15x12
Part No	mm	Quantity
D609	1160	2
DV358	608	1
DV359	1228	1
DV373	608	1
DV374	1228	1
DV363	1160	2
DV391	632	1
DV392	x 1252	1
D174		4
D227 Rubber	1000	10
SYBOL M6X11		8
SYBOL M6X15		4
SYBOL M6X22		4
SYNUT M6		12

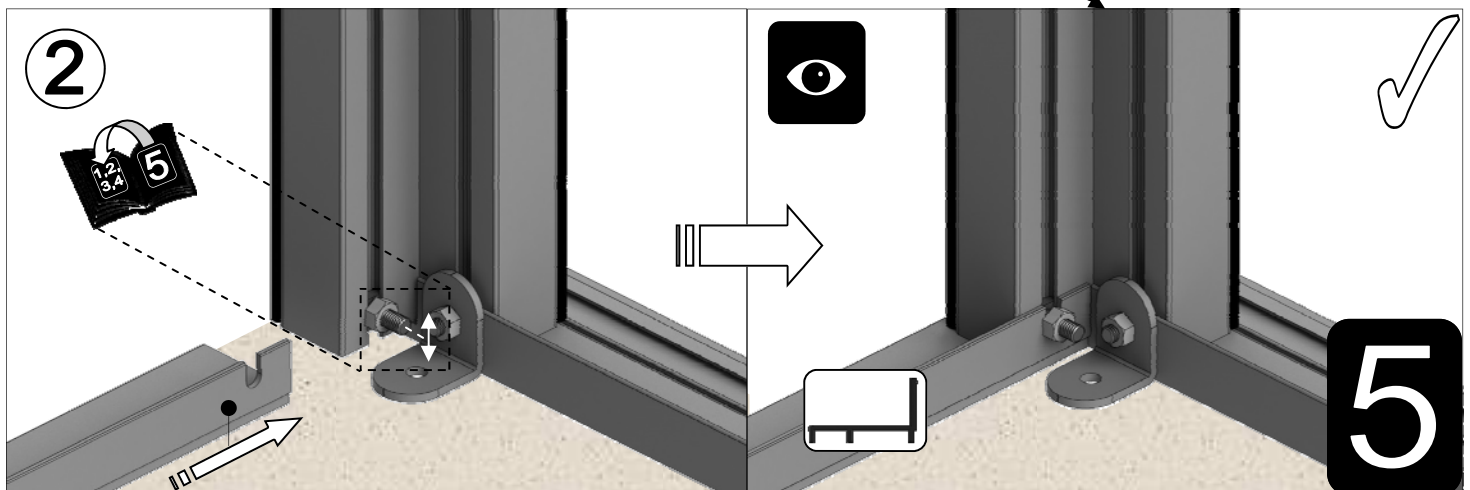
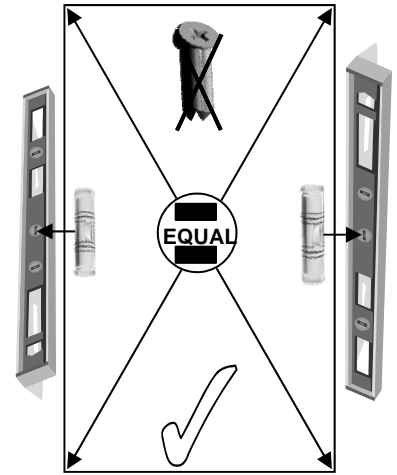
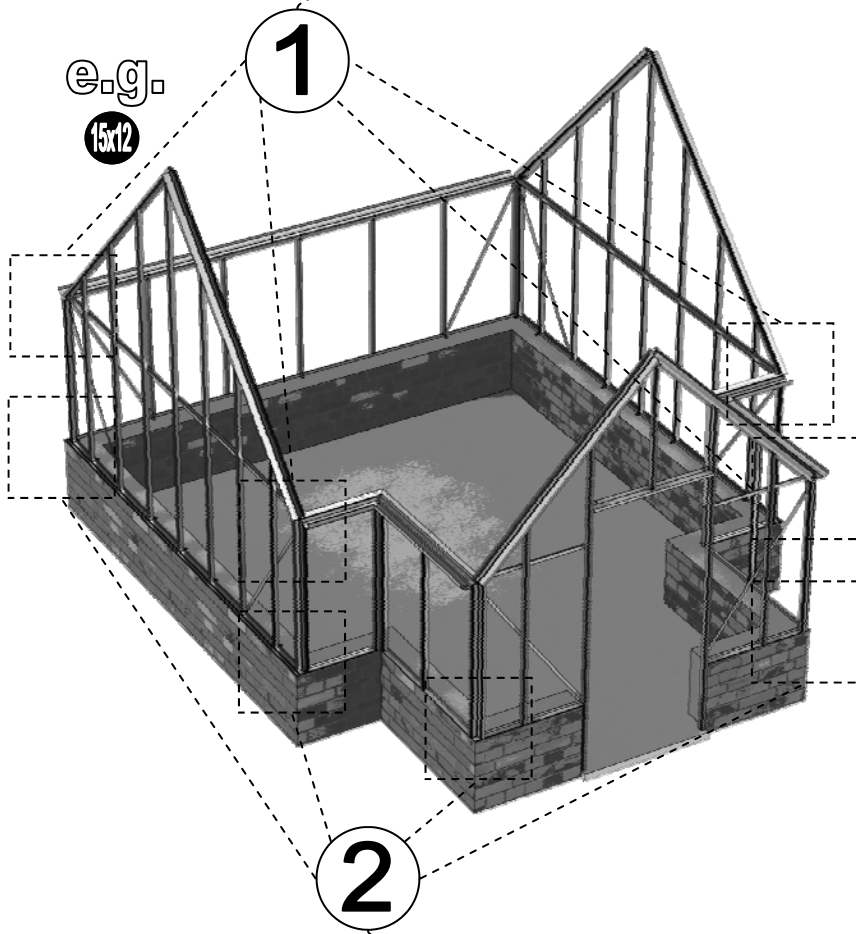
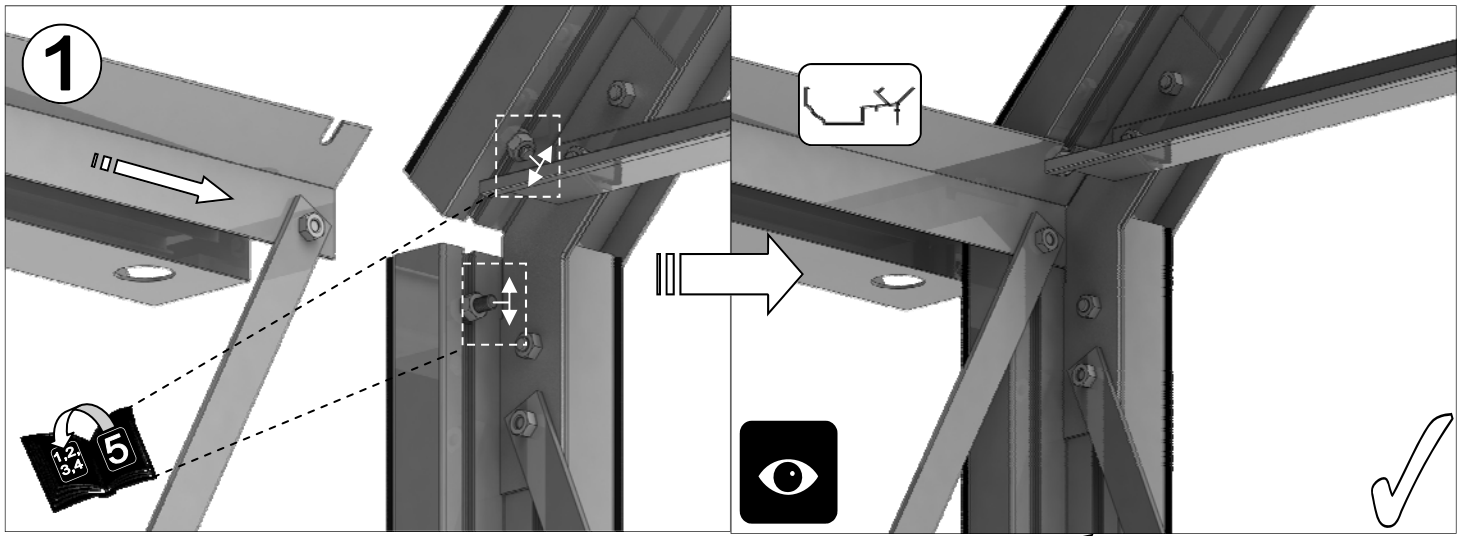

4



REAR ROOF		15x12
Part No	mm	Quantity
DV203	3757	1
DV255	2450	5
DV100	n/a	7
D227 Rubber	1000	25
SYBOL M6X11		10
SYBOL M6X22		20
SYNUT M6		34

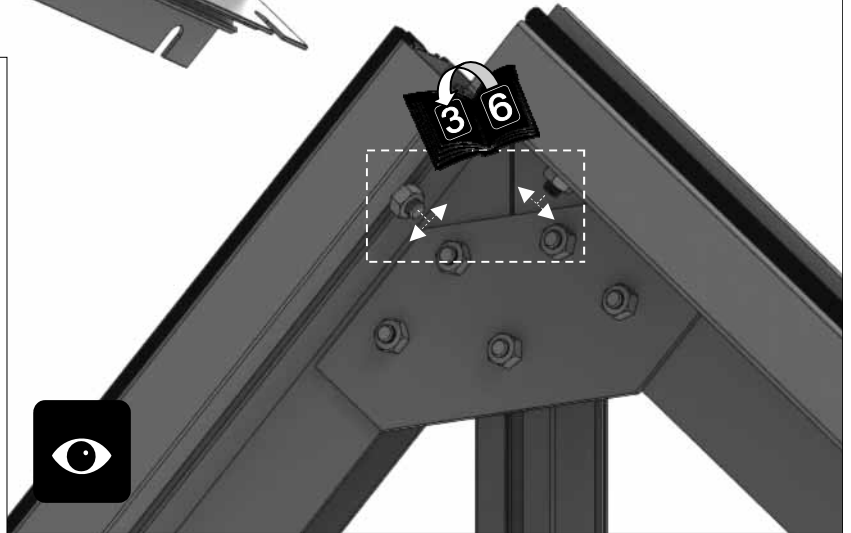
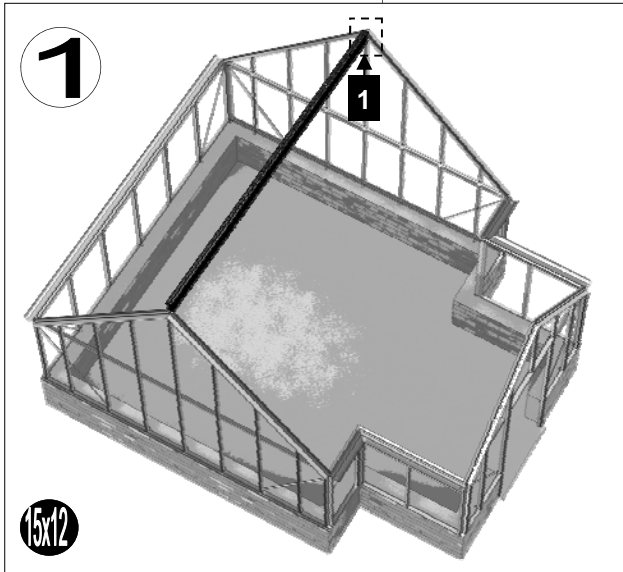
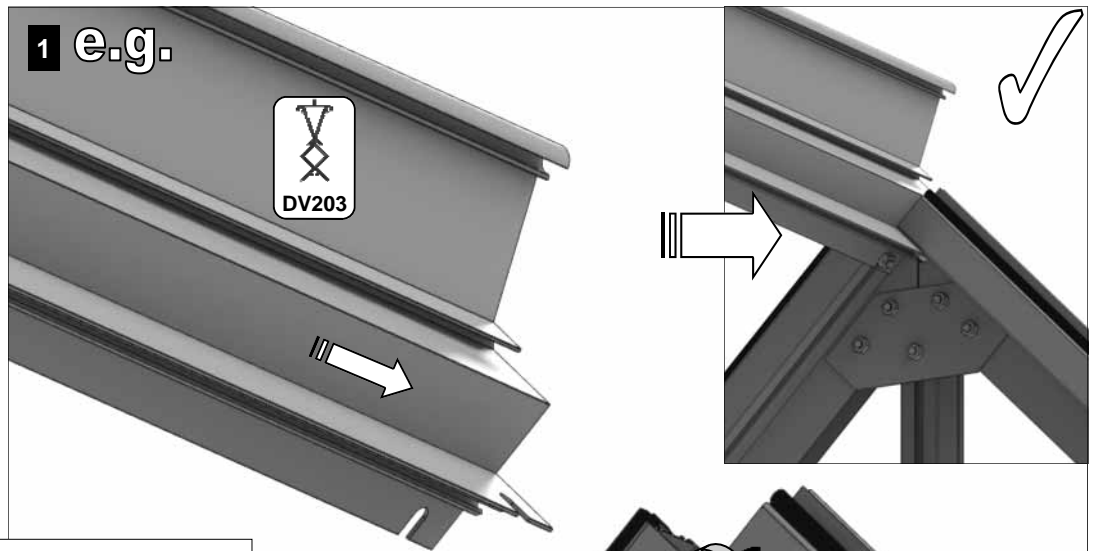



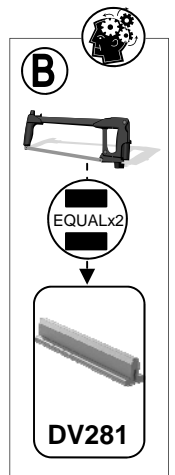
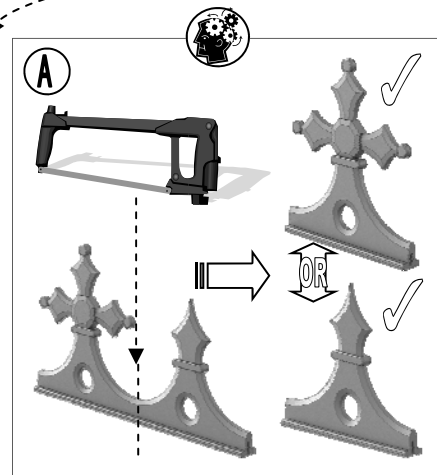
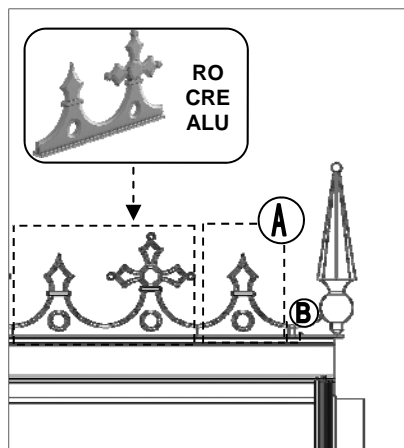
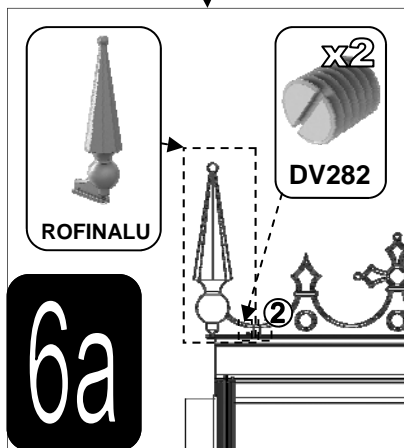
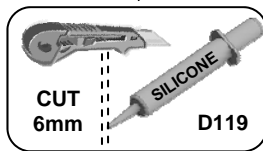
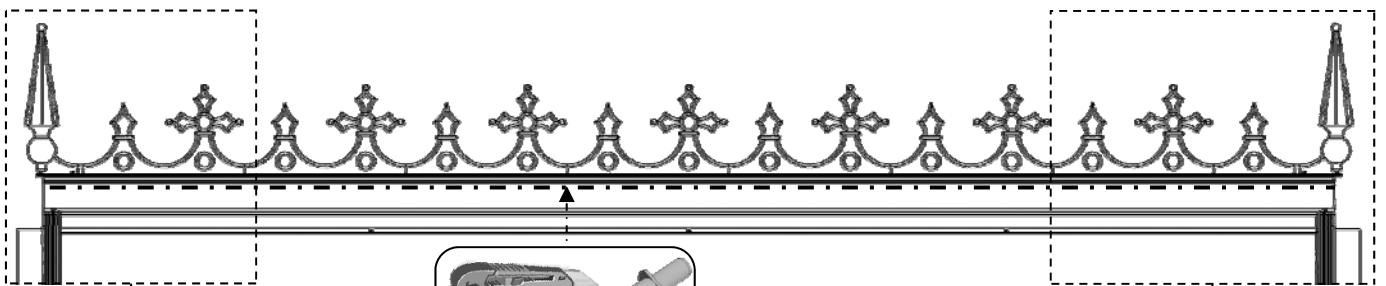

- End finials need to be pinched onto the ridge using 'DV282' grub screws.
- Depending on your ridge length a half cresting may need to be cut. Some spacer bar may also be required 'DV281' cut into two equal sections.
- Each finial and cresting piece needs to be siliconed 'D119' into place.

2

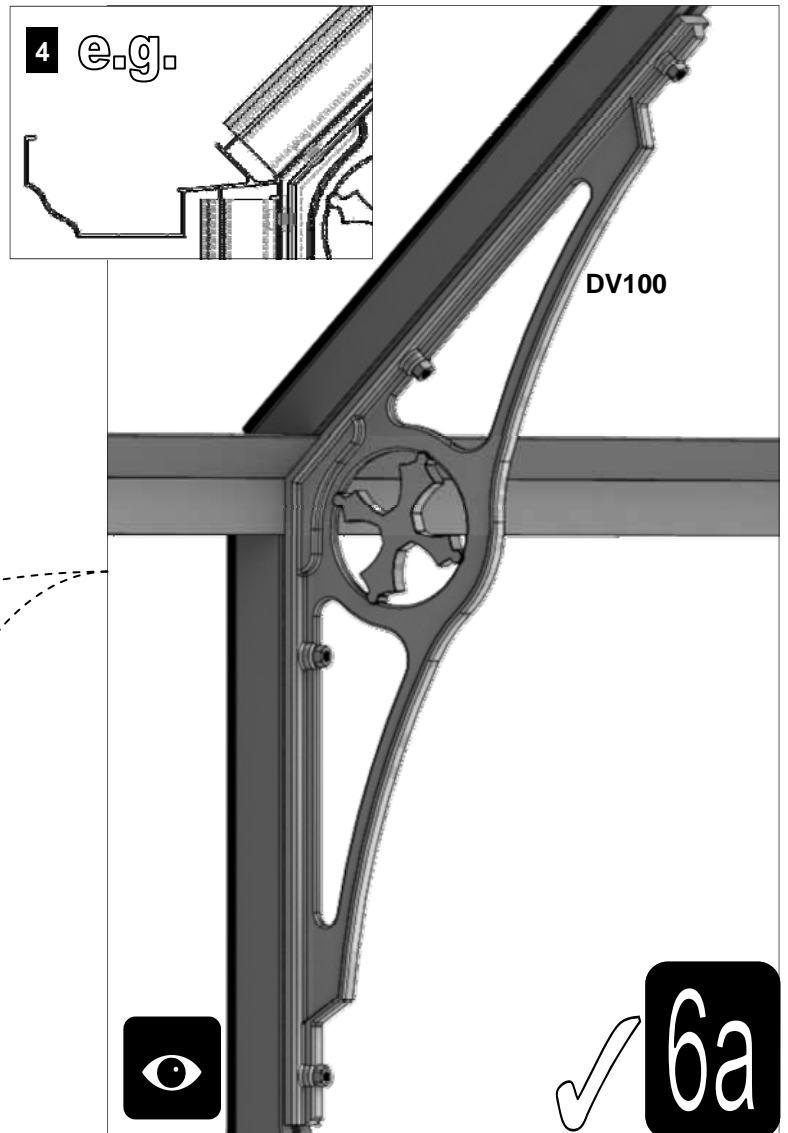
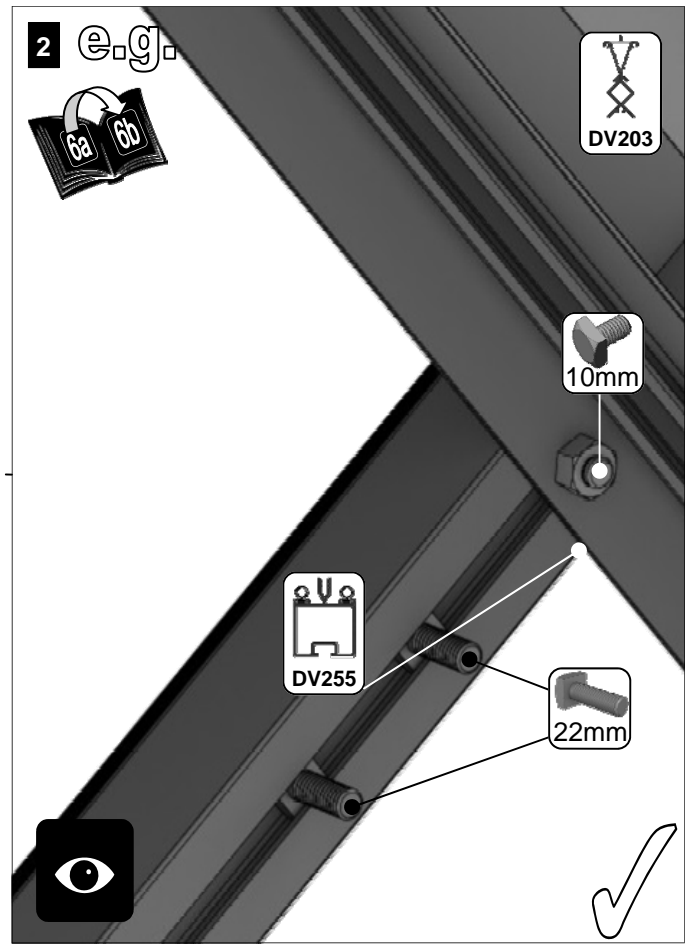
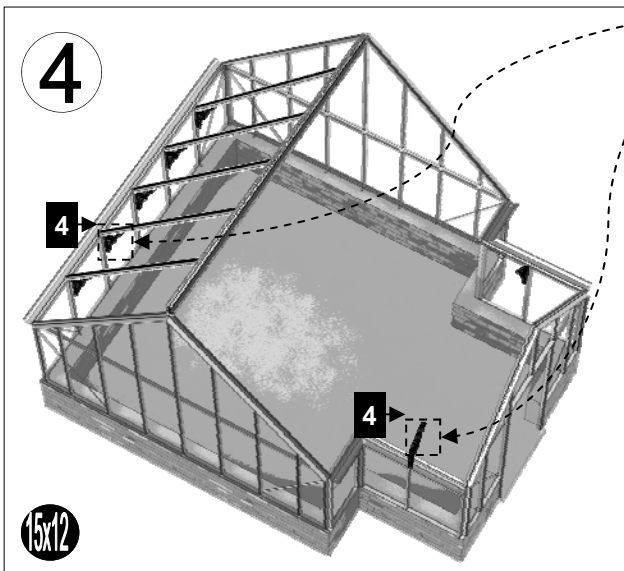
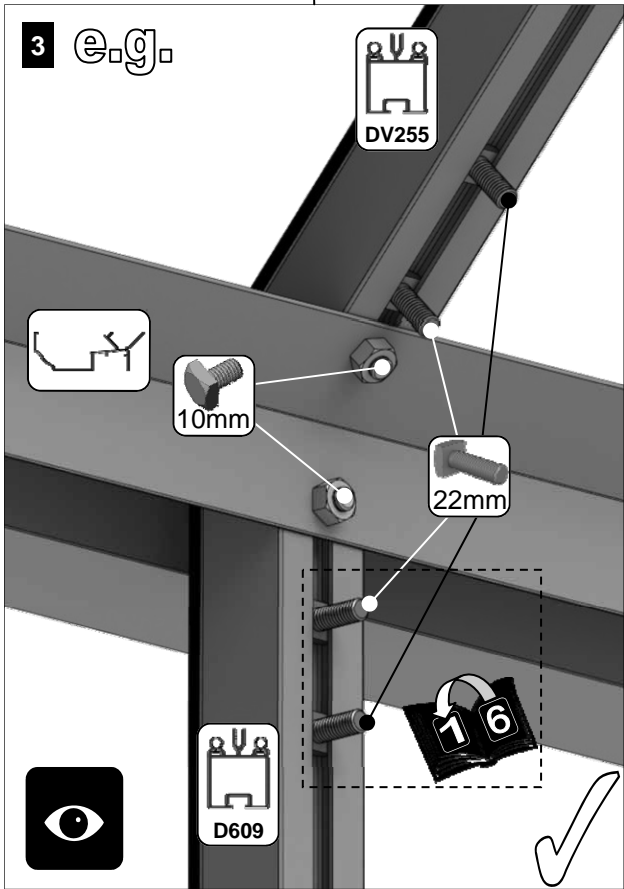
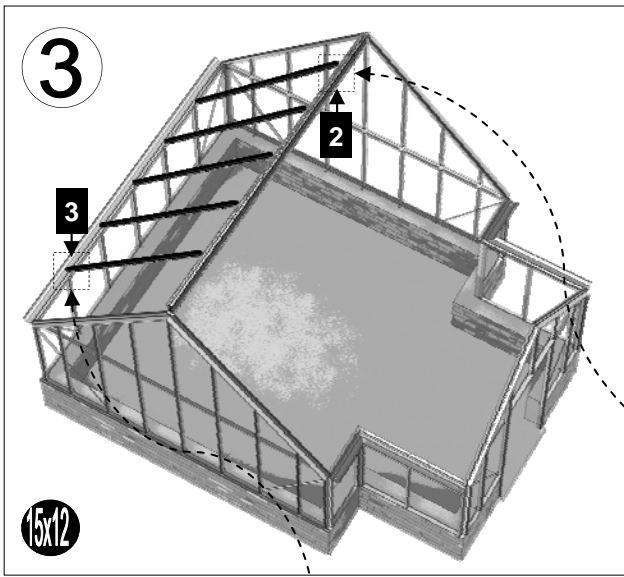





PORCH ROOF		15x12
Part No	mm	Quantity
D982	100	2
DV101	n/a	8
DV254	1790	2
DV351	2470	1
DV365	899	1
DV375L	830	1
DV375R	830	1
DV376L	1708	1
DV376R	1708	1
DV377L	1492	1
DV377R	1492	1
DV378L	2368	1
DV378R	2368	1
DV379	2212	2
DV380	n/a	1
DV383	661	1
D227 Rubber	1000	35
SYBOL M6X11		34
SYBOL M6X22		26
SYNUT M6		60

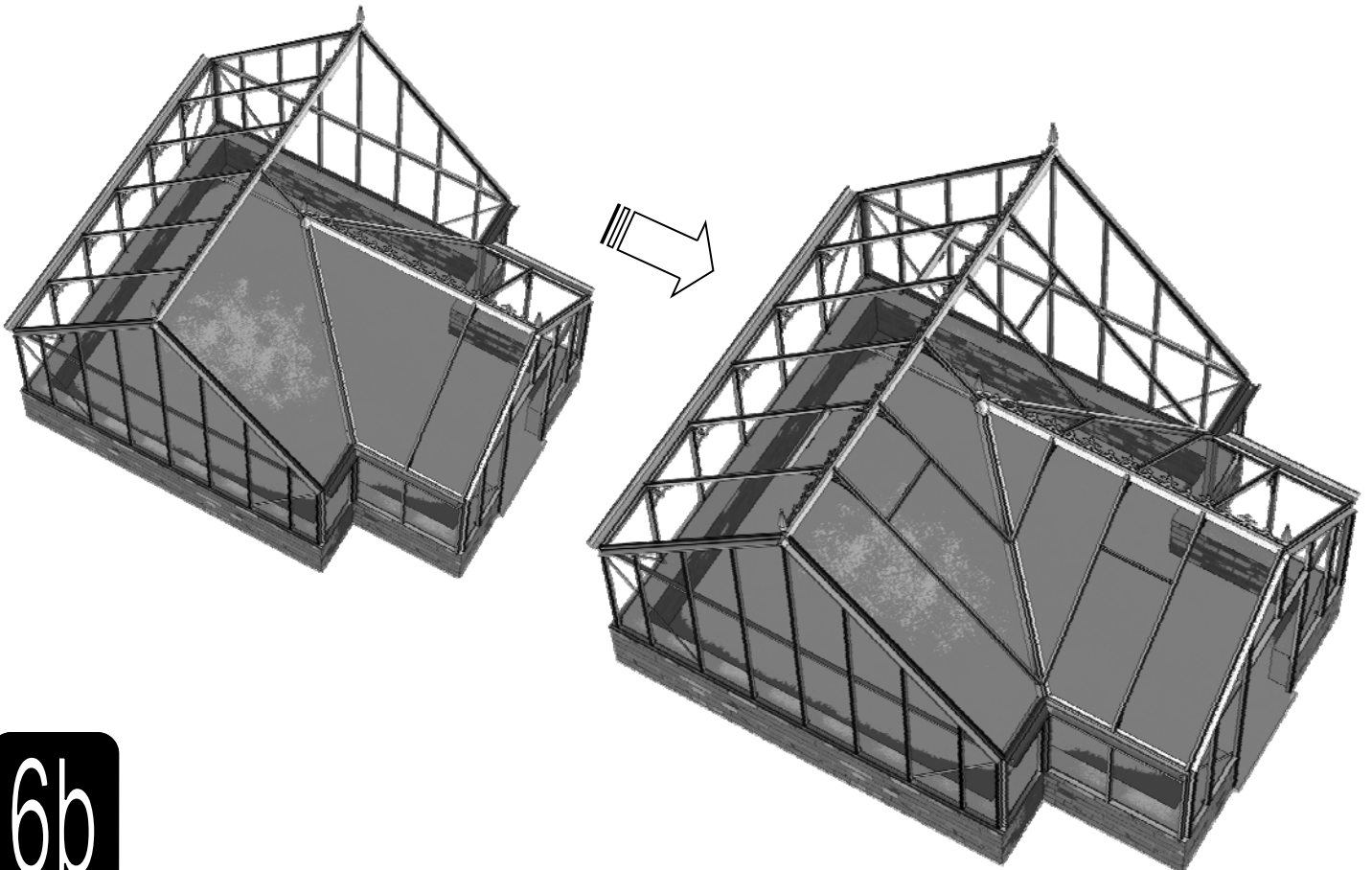
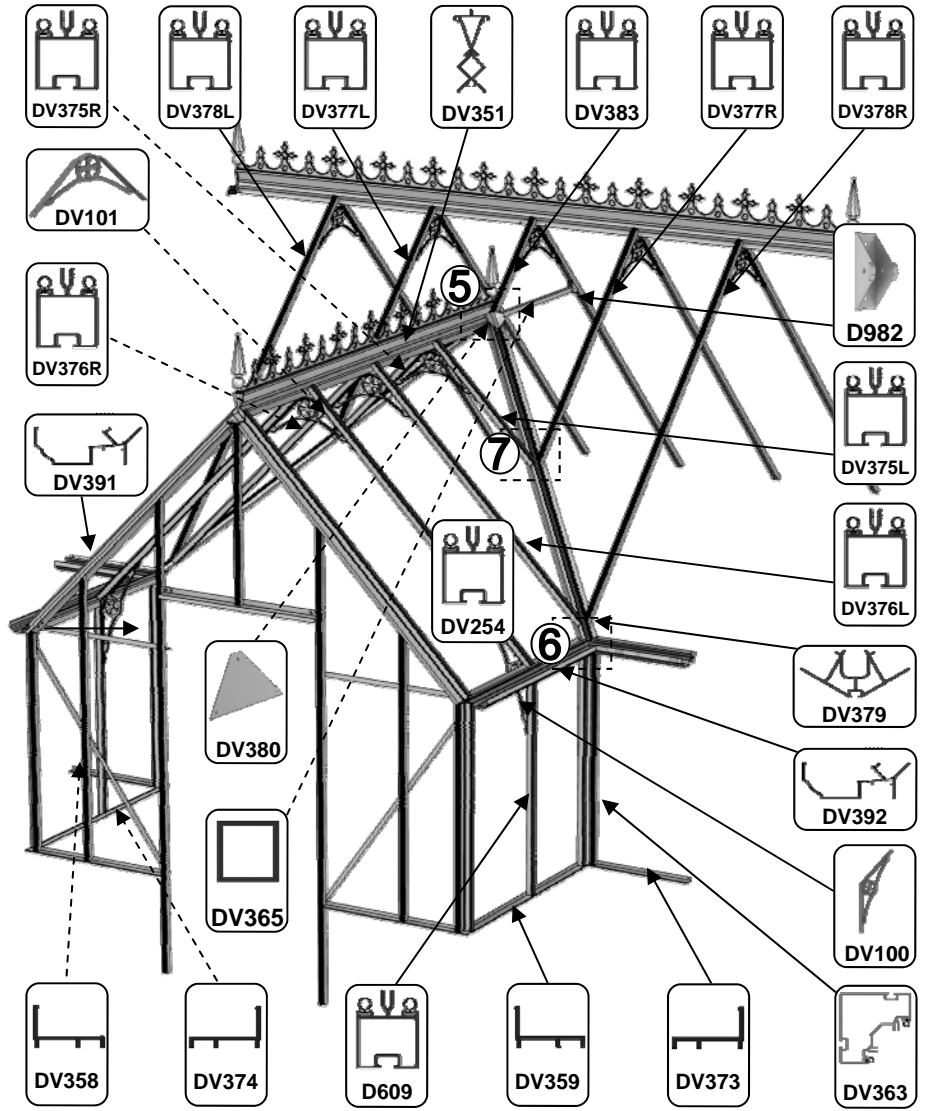

6b

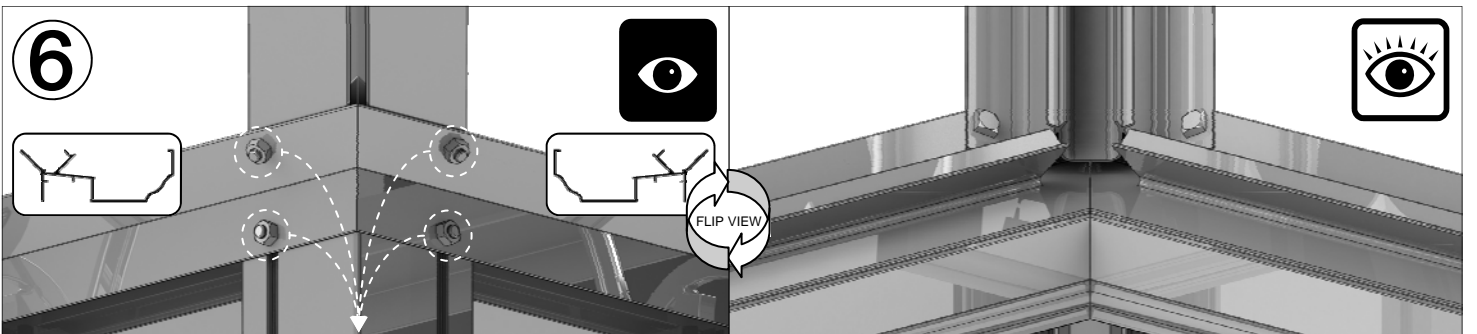
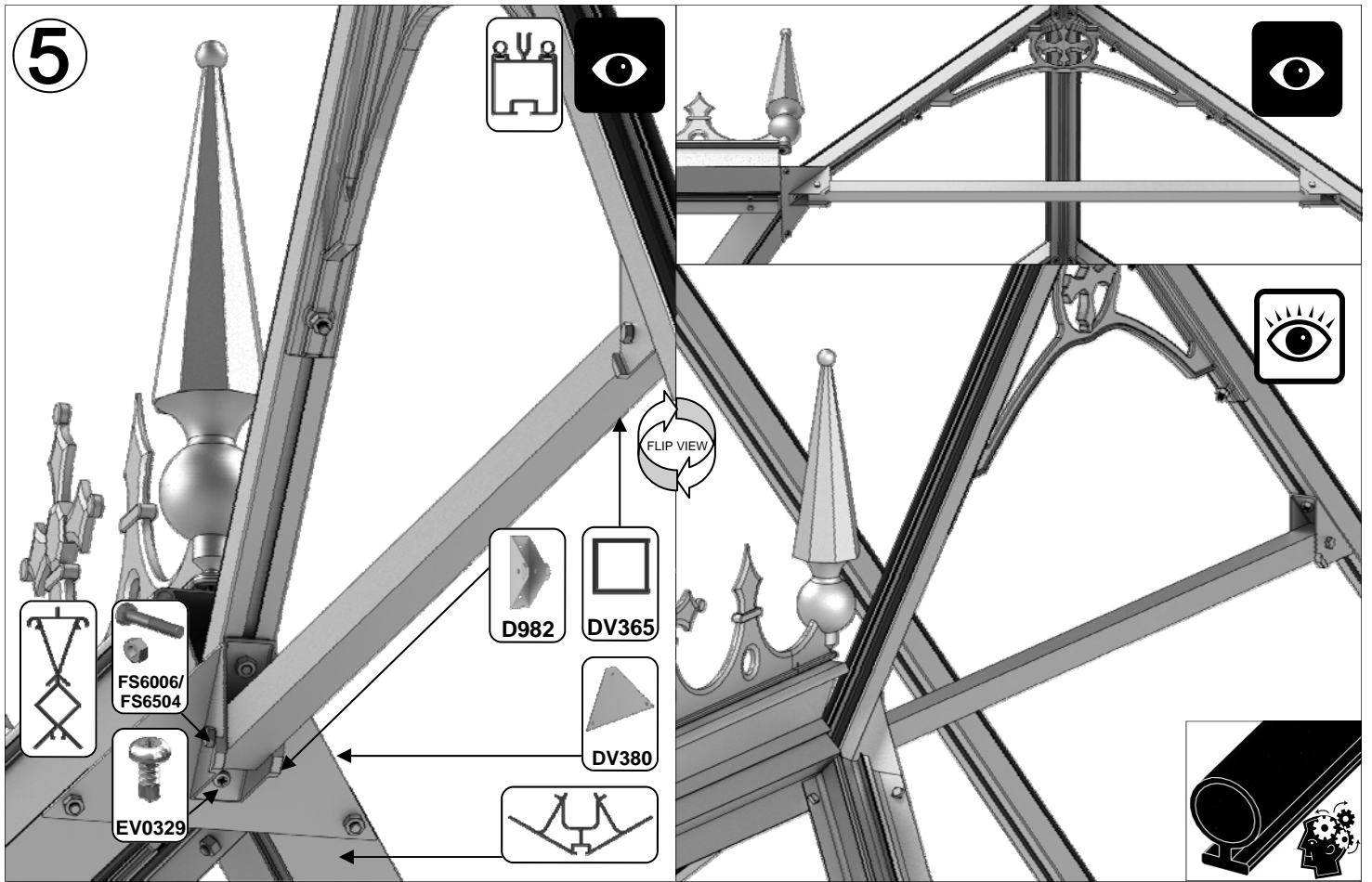

**IMPORTANT:** Because your porch gutter sections are welded together to eliminate the chance of any leaks the holes circled above can vary slightly in their locations. They may therefore require slight alteration to marry up with DV363 and DV379. Using an 8mm drill bit to enlarge the standard 7mm holes will for example give a little more play to aid fitting.

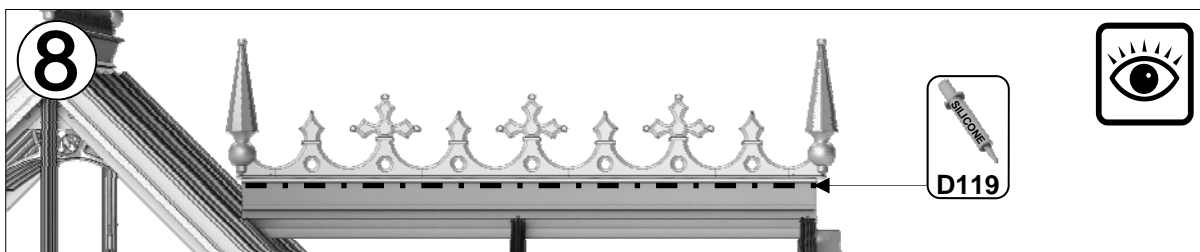
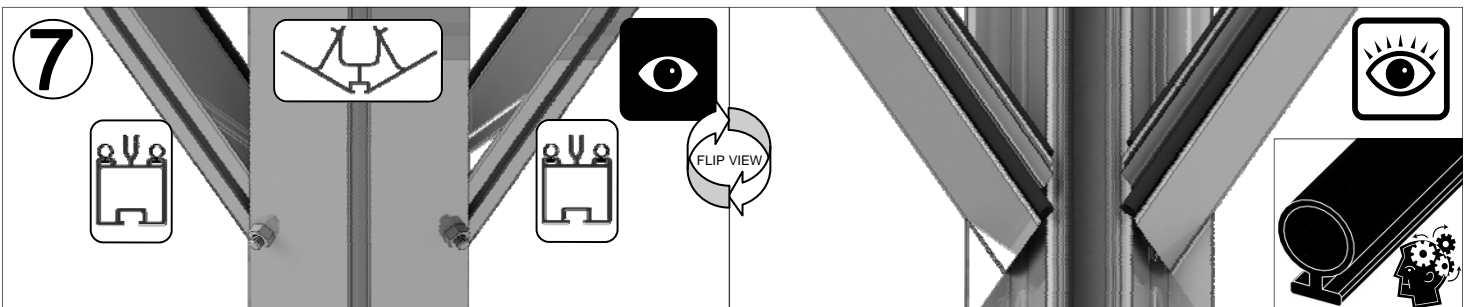

**6b**



**D1208**  
1 of -  
610 x 610  
pane

Part No		mm	Quantity
D866		639	1
D863L		613	1
D863R		613	1
D862		593	1

Part No		mm	Quantity
D220 PLUS SCREW		N/A	2
D205		N/A	2
SYBOL M6X11		10	4
SYNUT M6		M6	4
8 X 12 S/T FS6017		10	2
8 x 19 S/T FS6018		19	2

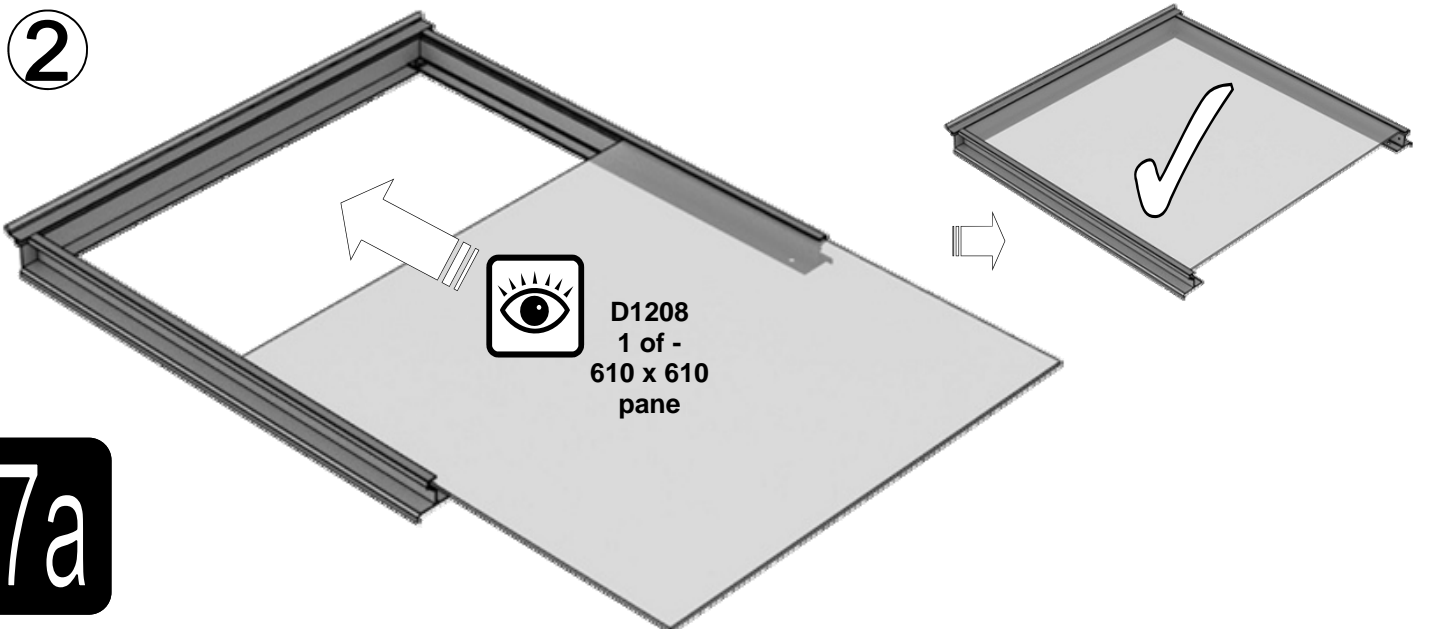
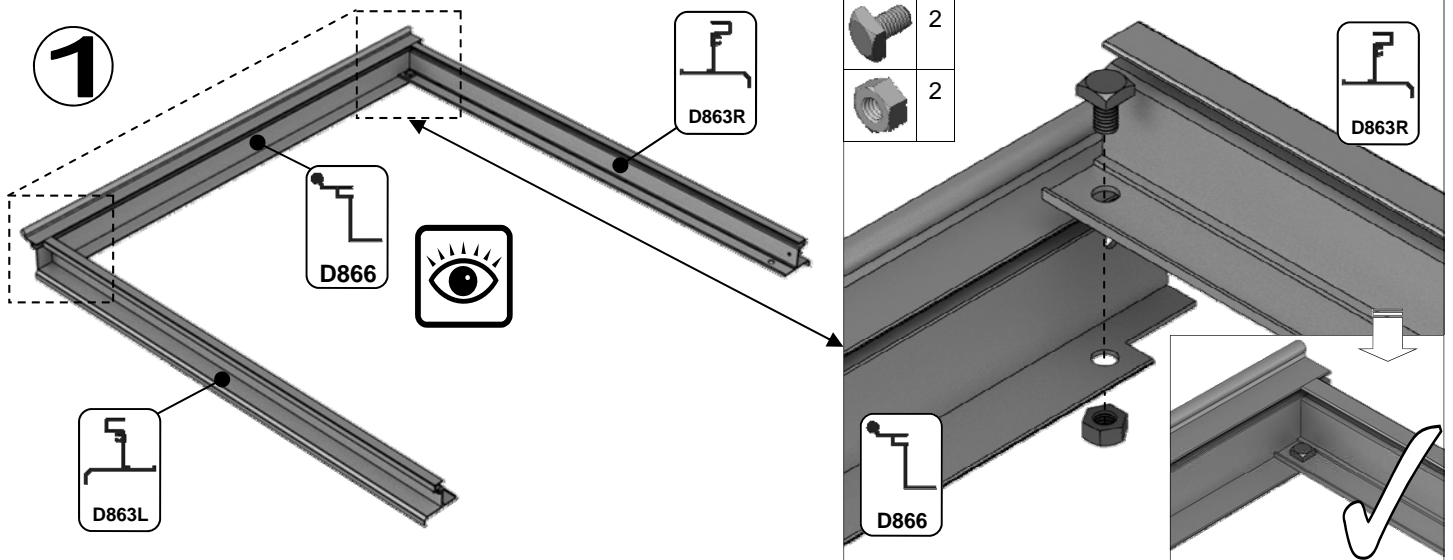



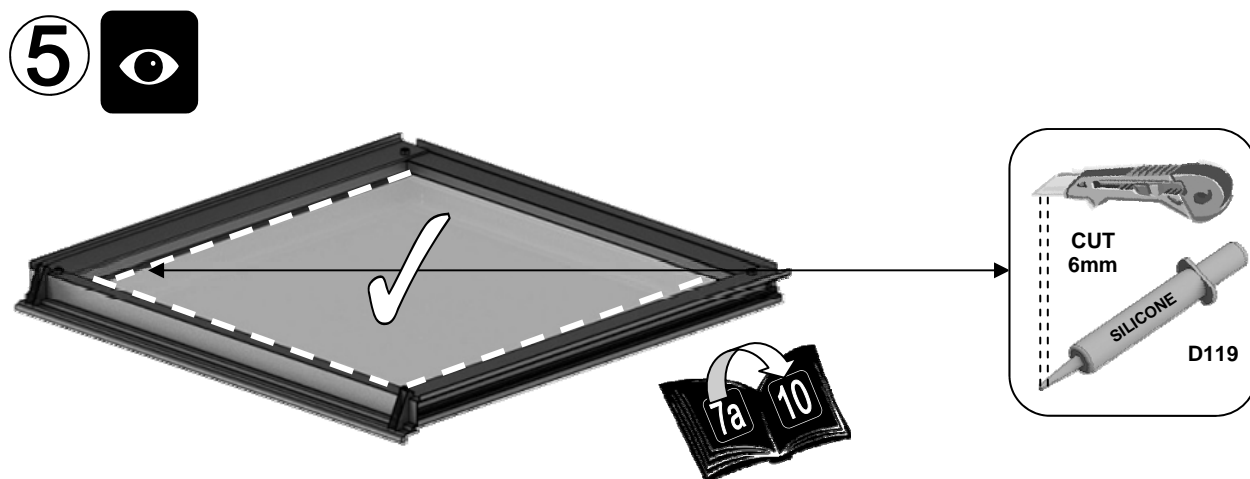
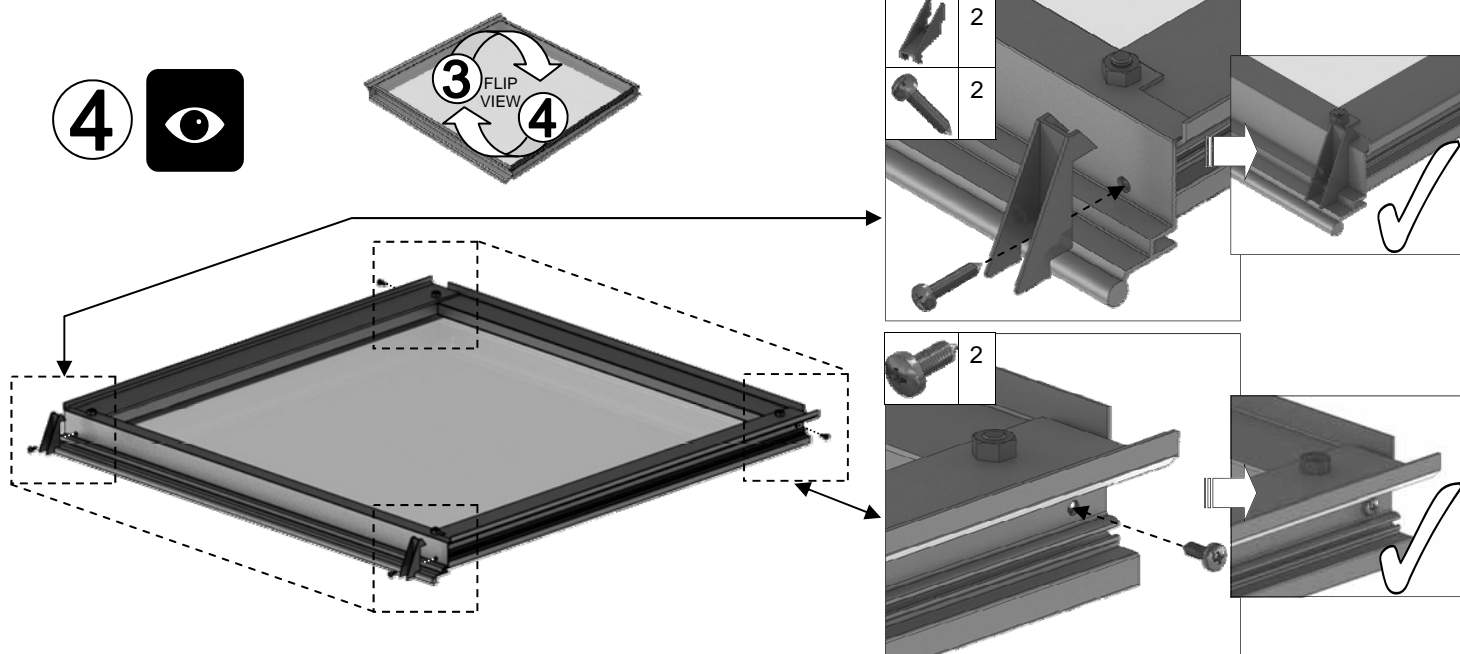
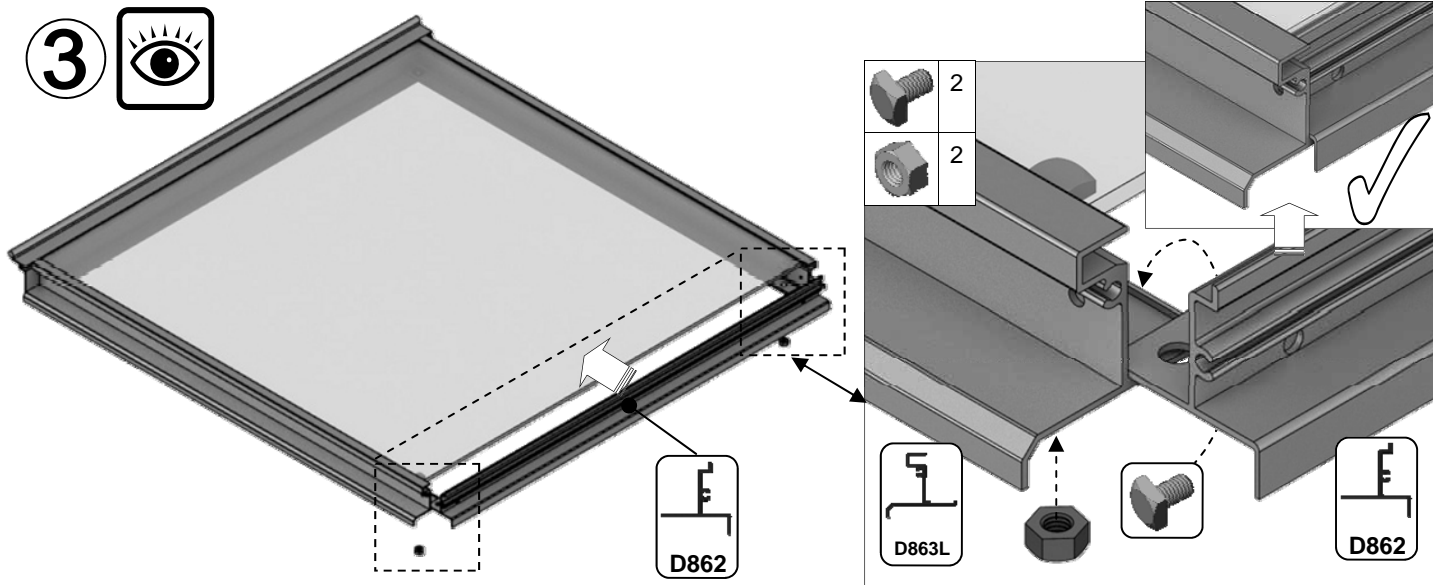



**7a**



**7a**

1 vent  
slam bar = {

Part No		mm	Quantity
SY-BOLM6X11		10	2
SY-BOLM6X15		15	2
SYBOLM6 X11CROP		10	2
SYNUTM6		N/A	4

Part No		mm	Quantity
D079 PLUS FLUFF		590	1
D114		N/A	2

6

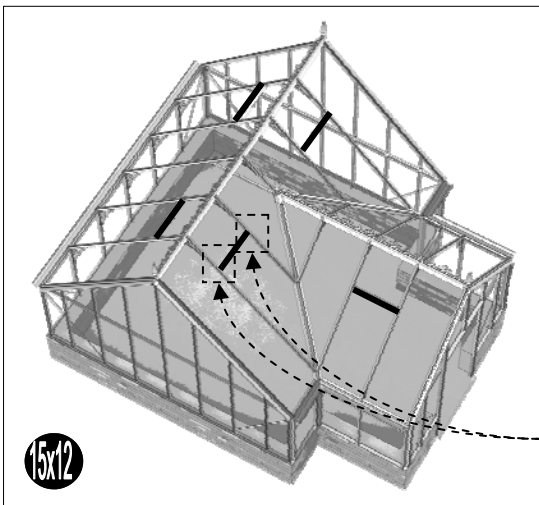
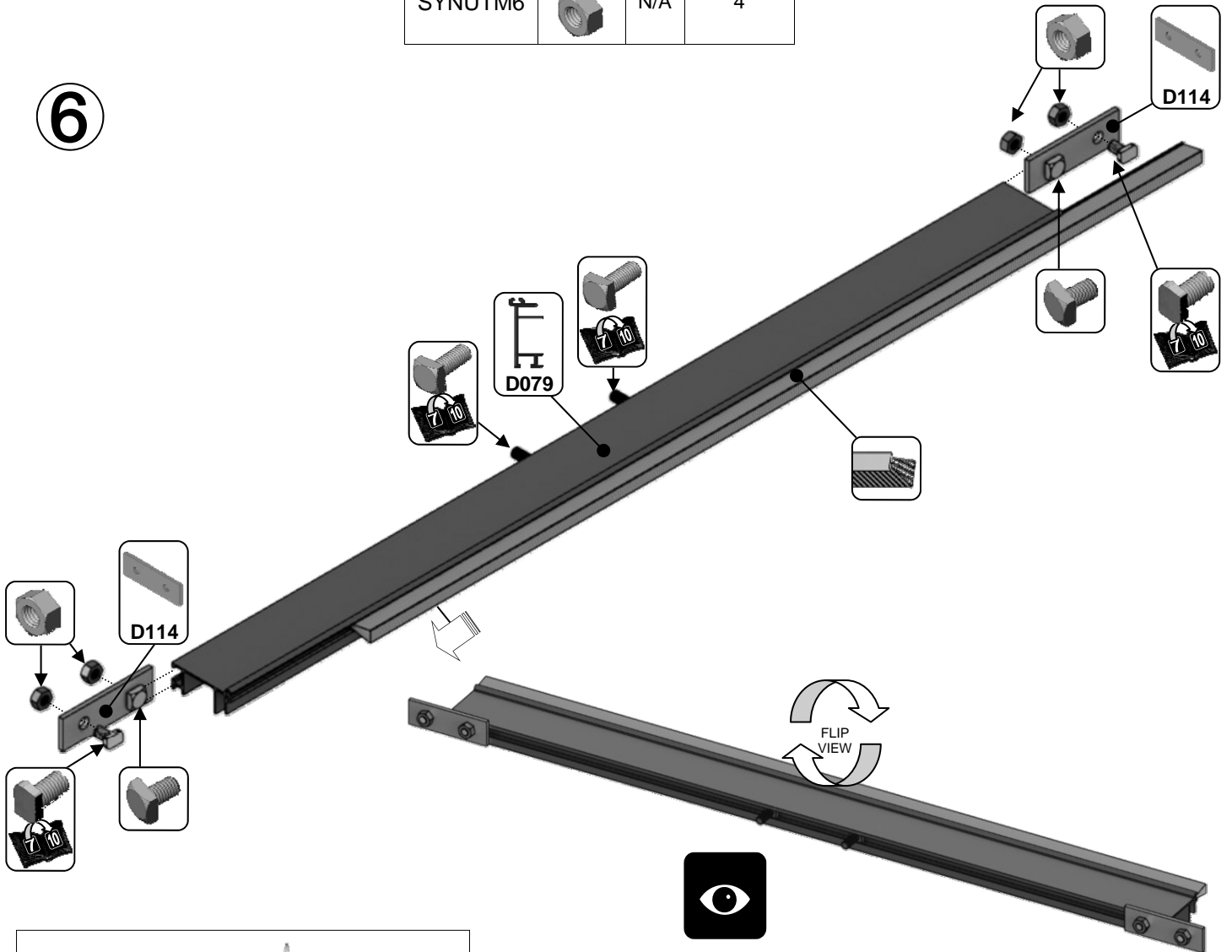

7b

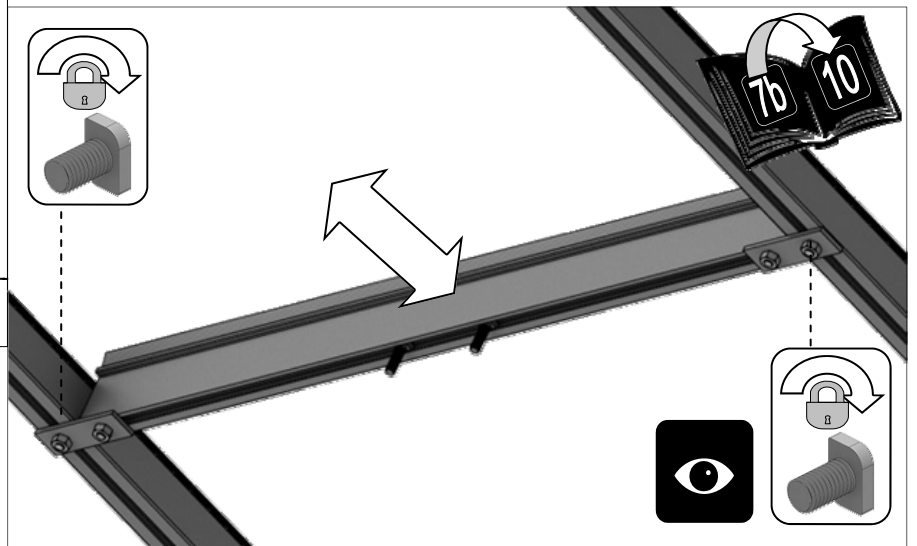

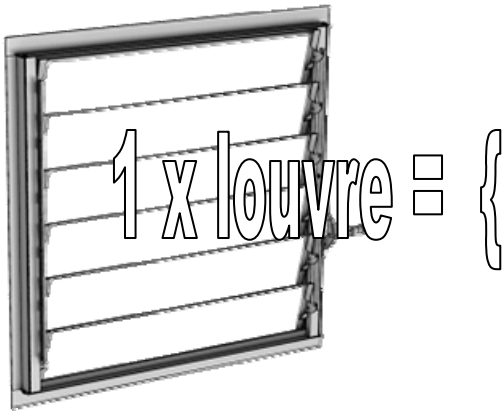

Part No		mm	Quantity
D168L		552	1
D168R (handle)		552	1
D165		612	2
D166		552	2
FS6013		12	4

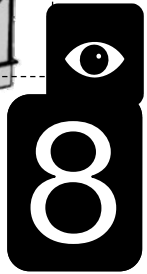
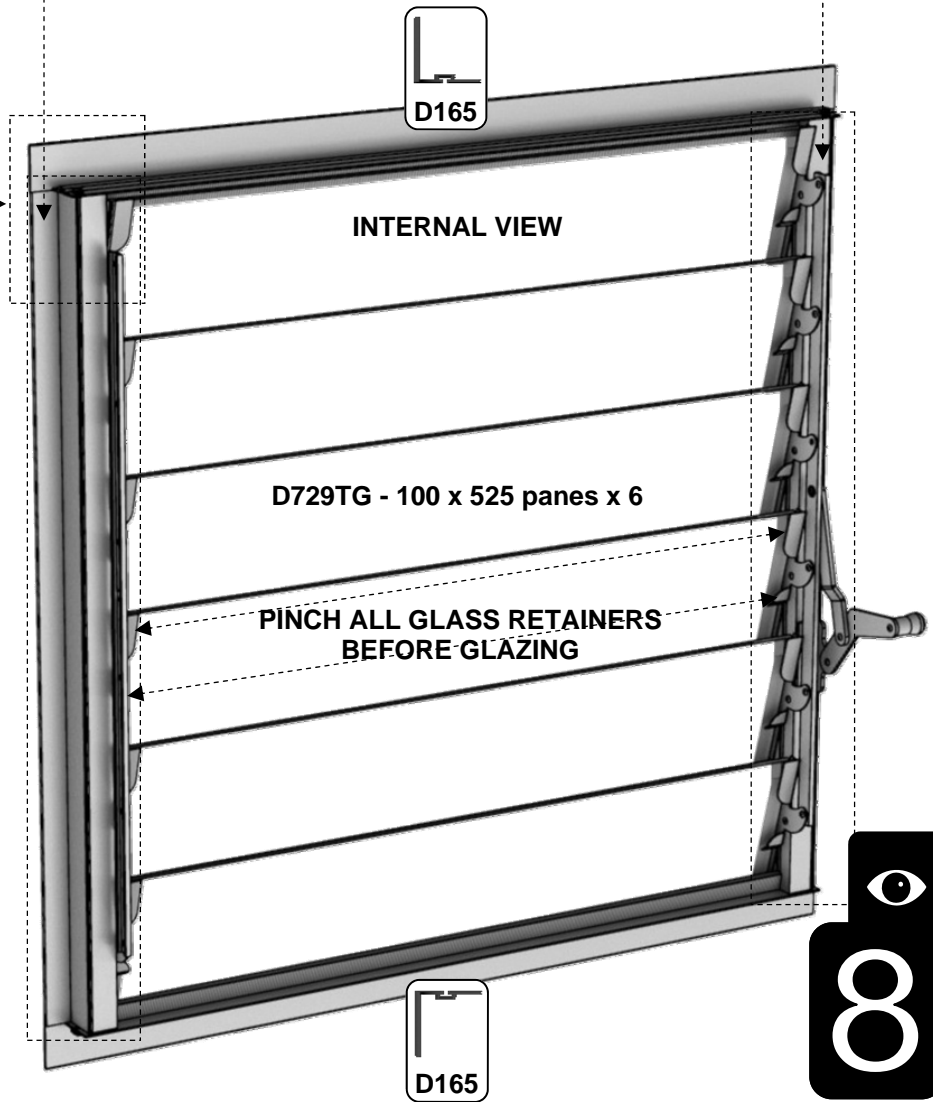
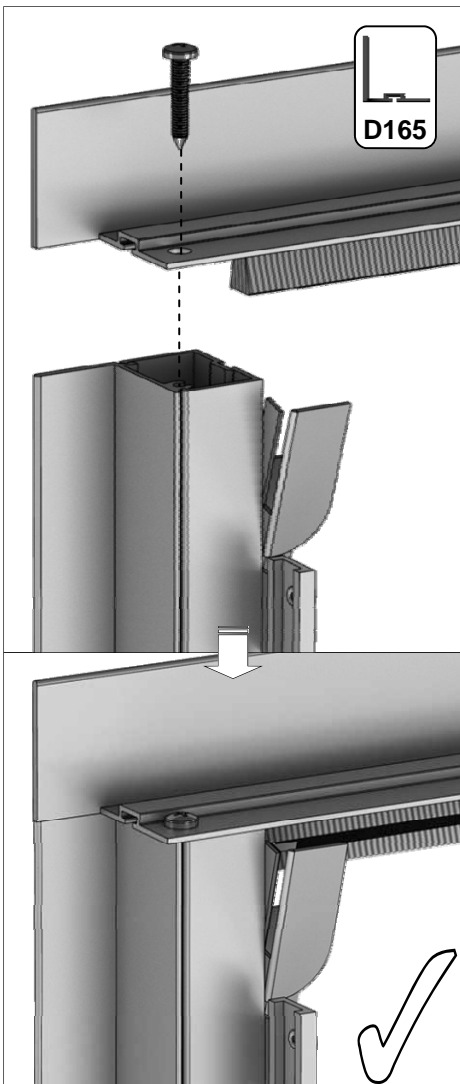
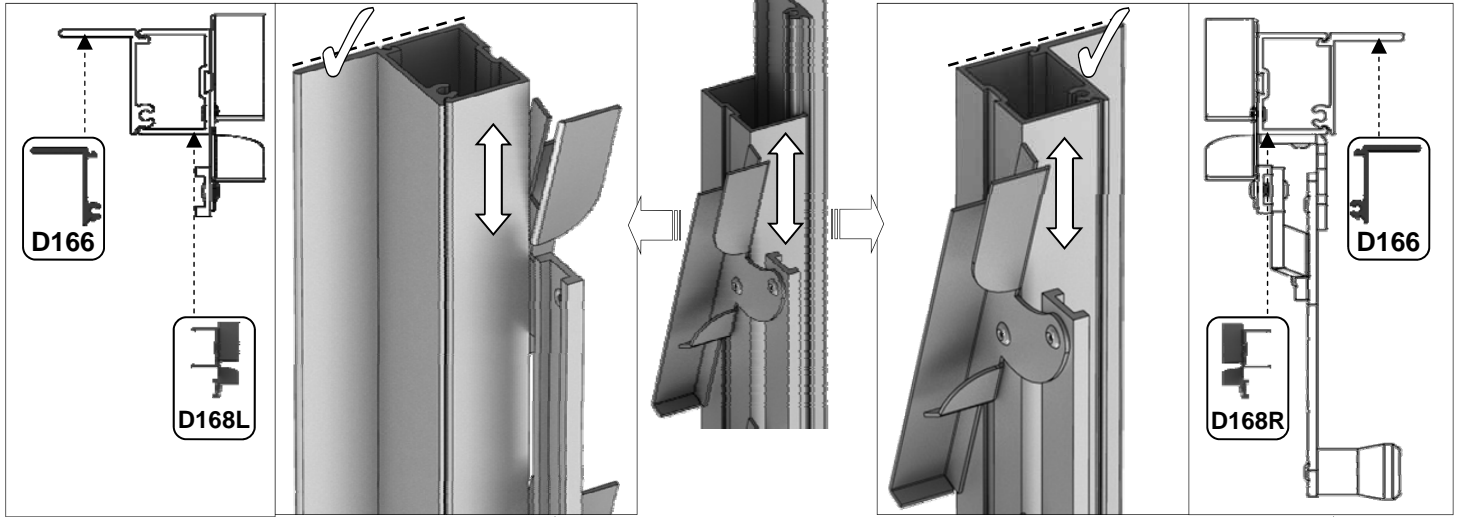

PORCH CAPS AND COVERS		15x12	
PART No	SECTION	SIZE (mm)	QUANTITY
D618		1144	11
D870		601	9
DV403L/R		1505	3 + 3
DV479		1384	1
DV610L/R		1972	2 + 2
DV612L/R		2438	2 + 2
DV637L/R		2489	1 + 1
DV654		1821	2
DV655		1880	5
DV659		2879	2
DV663		905	1
DV675L/R		863	1 + 1
DV676L/R		1741	1 + 1
DV677L/R		924	1 + 1
DV678L/R		1799	1 + 1
DV683		680	1
D610		1160	6
D620		1144	6
D871		601	4
DV651		1790	2
DV652		1871	4
D614		1162	6
D619		1144	17
DV480		1384	1
DV611L/R		1972	2 + 2
DV613L/R		2438	2 + 2
DV615L/R		1505	3 + 3
DV638L/R		2489	1 + 1
DV657		1821	4
DV658		2481	9
DV665		2879	2
DV669		905	1
DV679L/R		863	1+1
DV680L/R		1741	1+1
DV681L/R		1525	1+1
DV682L/R		2400	1+1
DV684		680	1

GLAZING (plans pto):

Glass and aluminium can potentially cause injury. Please ensure you wear protective goggles, gloves, headgear and suitable footwear when assembling and glazing the building.



Please remember that glass is fragile and should be handled with extreme care. Always clear up and dispose of any breakages immediately.

Layout the plastic bar cappings e.g. D618 and covers e.g. D619 around the building like a sundial checking that all is present and correct. You can also place the roof cappings in the gutters so they are closer to hand.

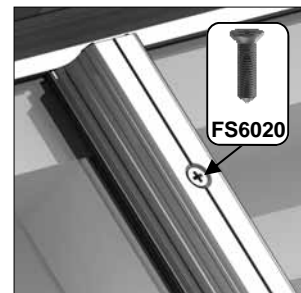

If you have a building which has aluminium cover caps then the roof covers are held in place with low-profile countersunk screws 'FS6020'. It looks neatest if all of these screws go towards the ridges of the building, see right.

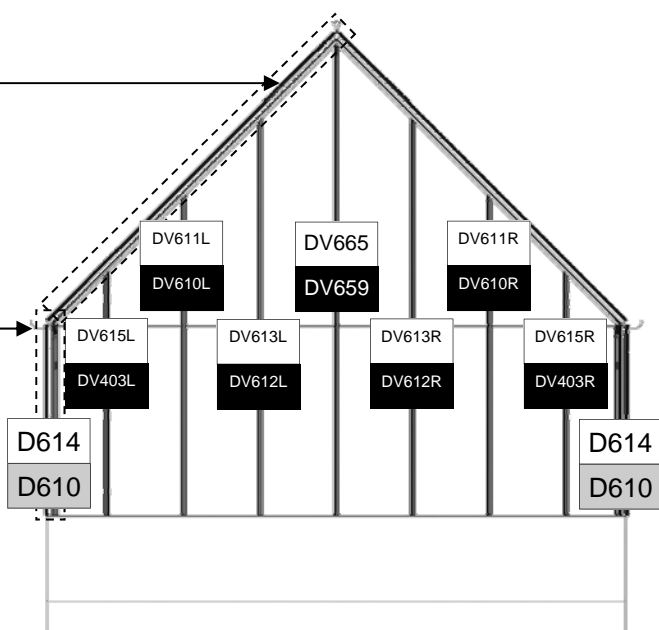
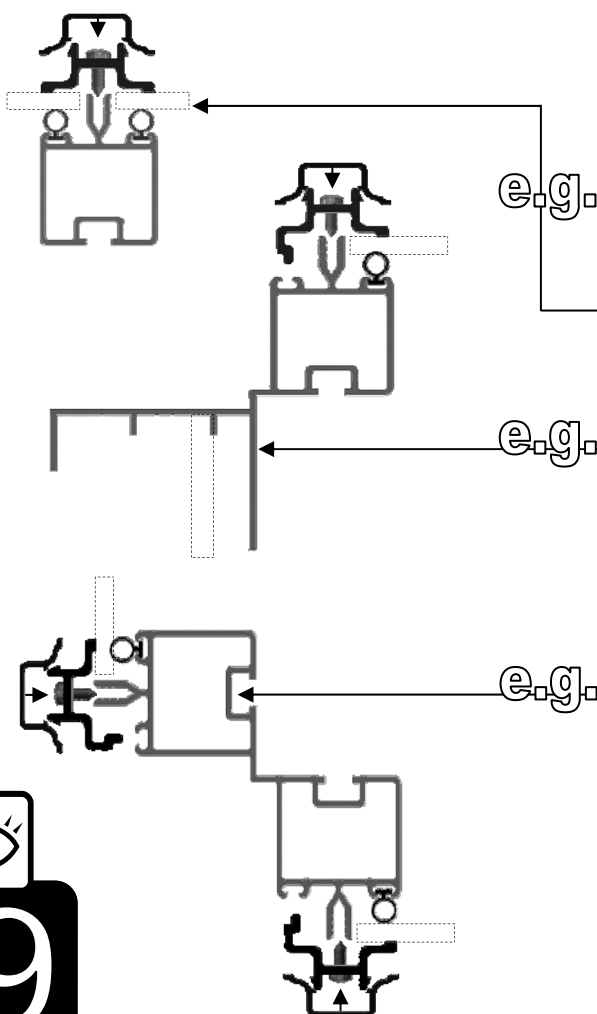
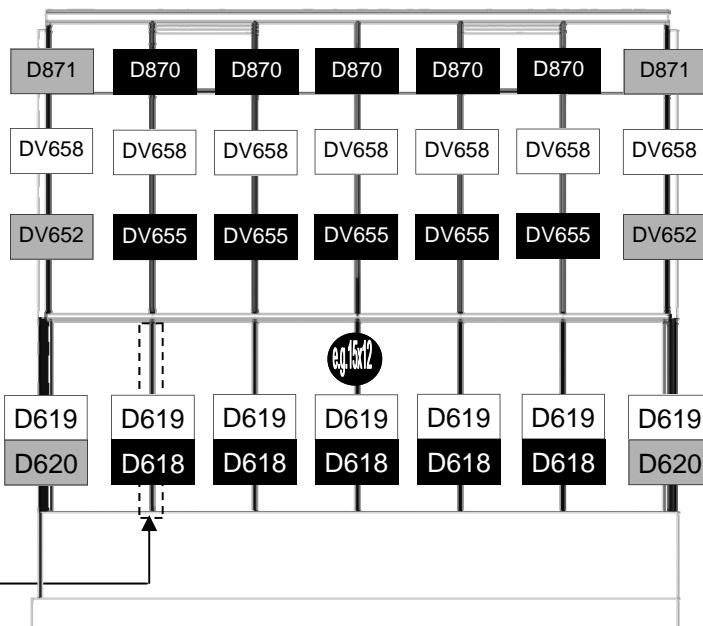



15x12

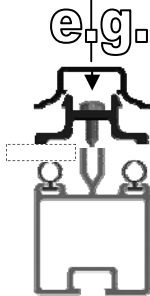
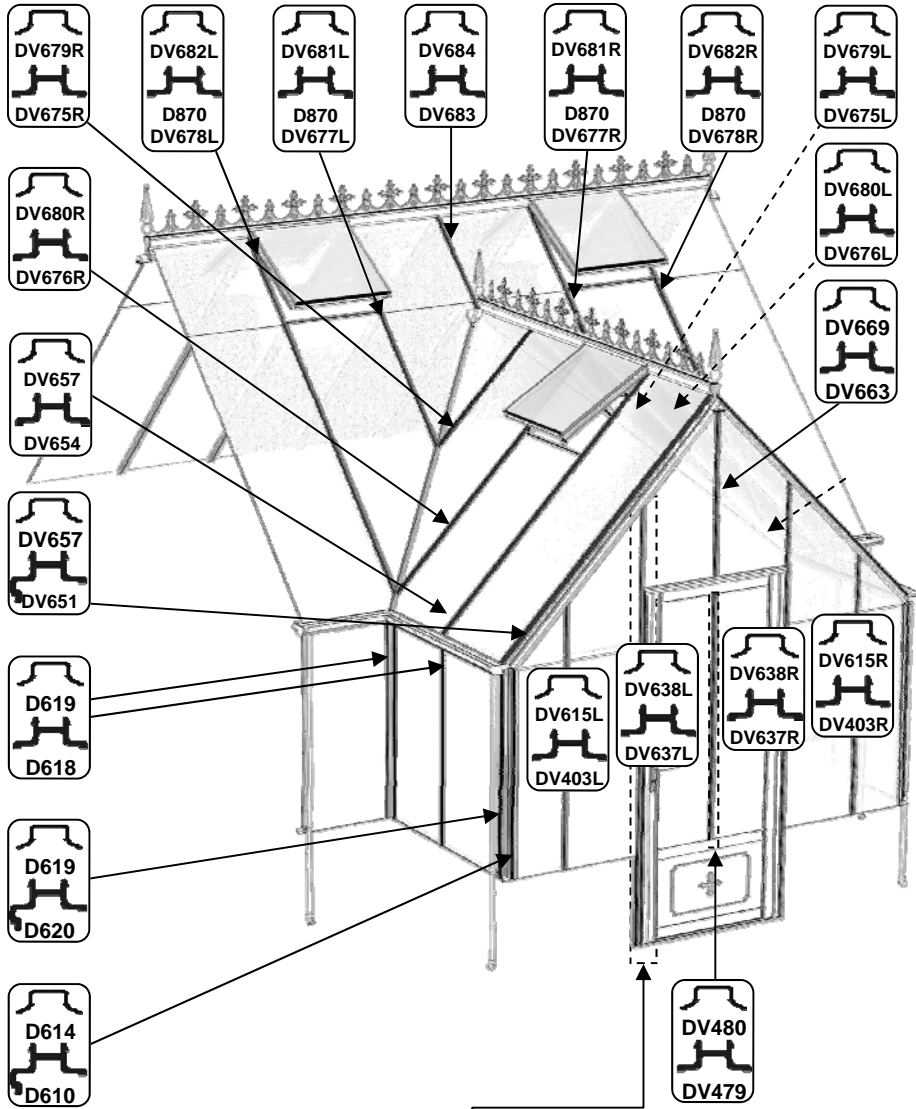

PORCH GLASS			15x12
PART No		Size (mm)	QUANTITY
D624	M	610 X 550	2
D625	N	305 X 1162	6
D729	L	525 X 100	12
D769	G	457 X 1162	14
D1208	A	610 X 610	13
D1216	S	610 X 1162	6
DV507	P	ANGLE	6
DV700	D	357 X 1384	2
DV701	W	521 X 1162	4
DV705	U	610 X 1828	2
DV713	K	ANGLE	6
DV714	J	ANGLE	4
DV715	H	ANGLE	2
DV716	T	ANGLE	4
DV725	E	ANGLE	2
DV726	X	ANGLE	2
DV727	Z	ANGLE	1
DV728	Y	SPECIAL ANGLE	2
DV729	C	ANGLE	2
DV730	I	ANGLE	2
DV732	O	ANGLE	1
610 X 1890	R	610 X 1890	6
D223/B		Cut to 904mm	1
D101 / ROSEPS	H	610 long (inc cuts to 457&305mm)	19 (inc louvers)

**IMPORTANT:** On the roof sections please make sure that you place a screw around 25mm / 1" from the bottom of each capping strip (create a hole in the plastic if required) and that the screws are nice and tight to avoid any glass slippage.

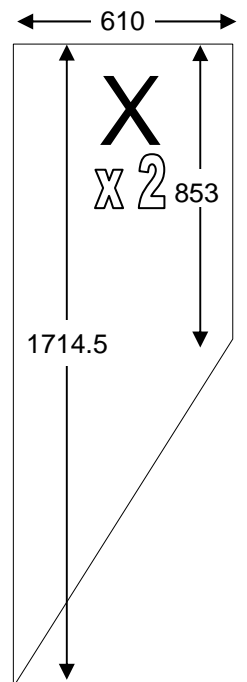
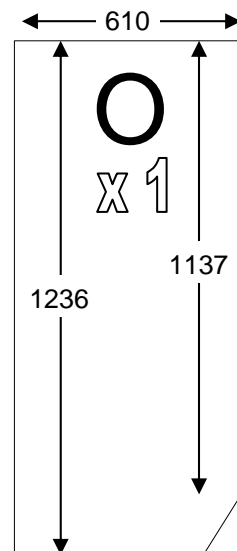
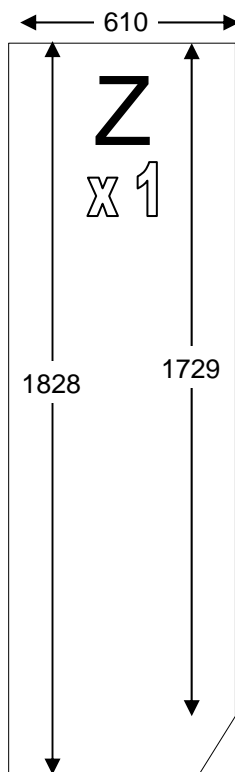
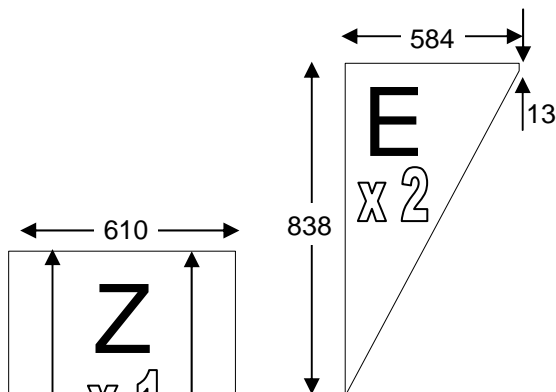
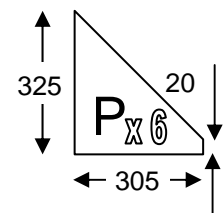
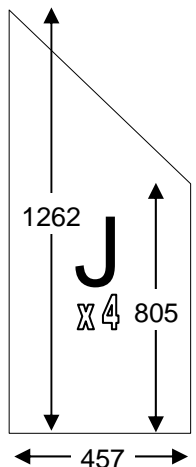
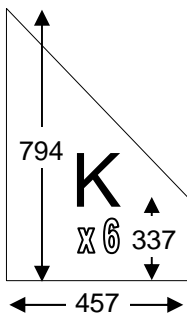
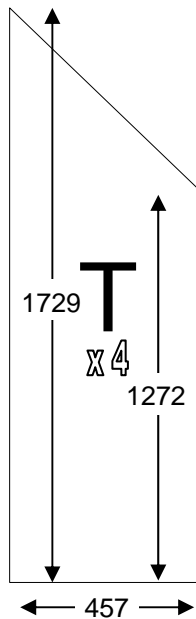
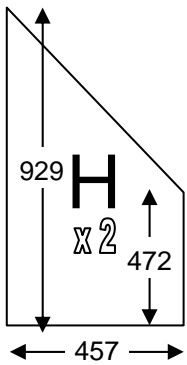
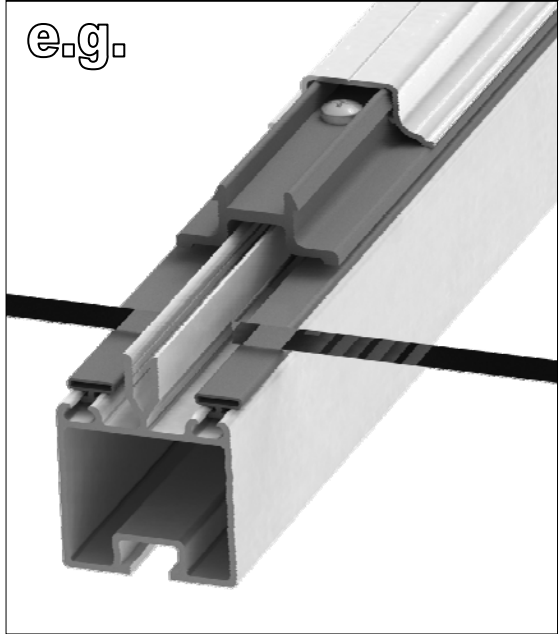



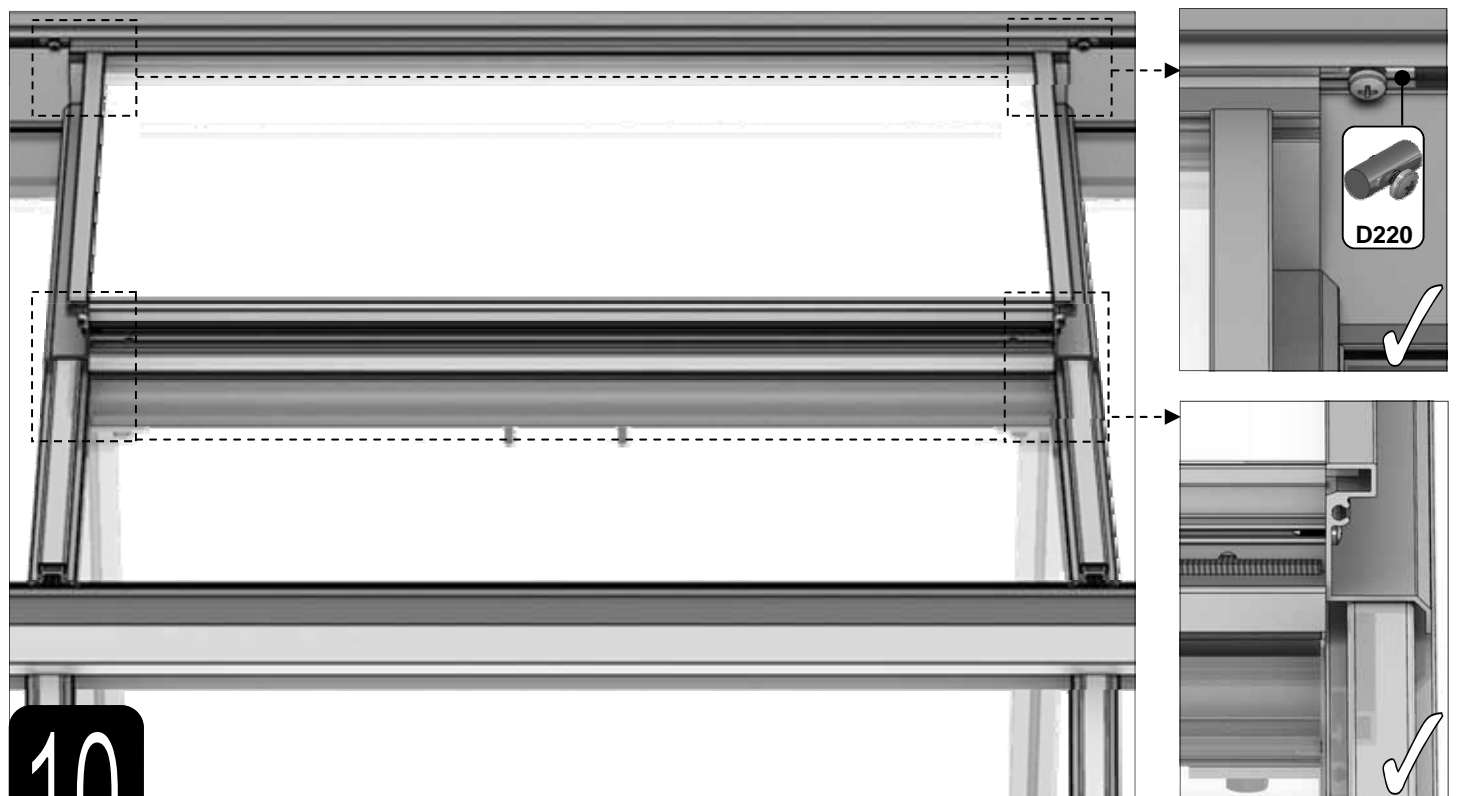
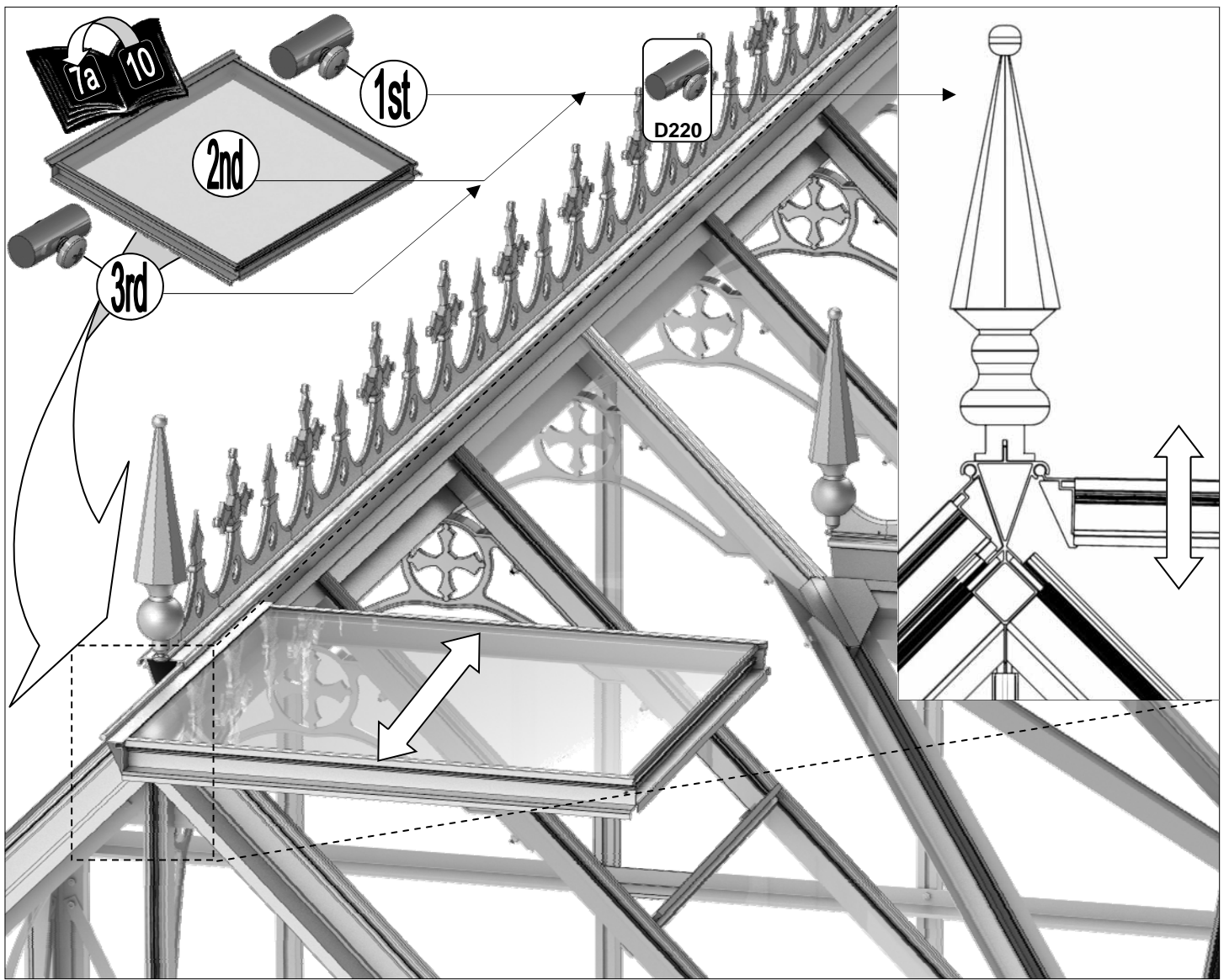

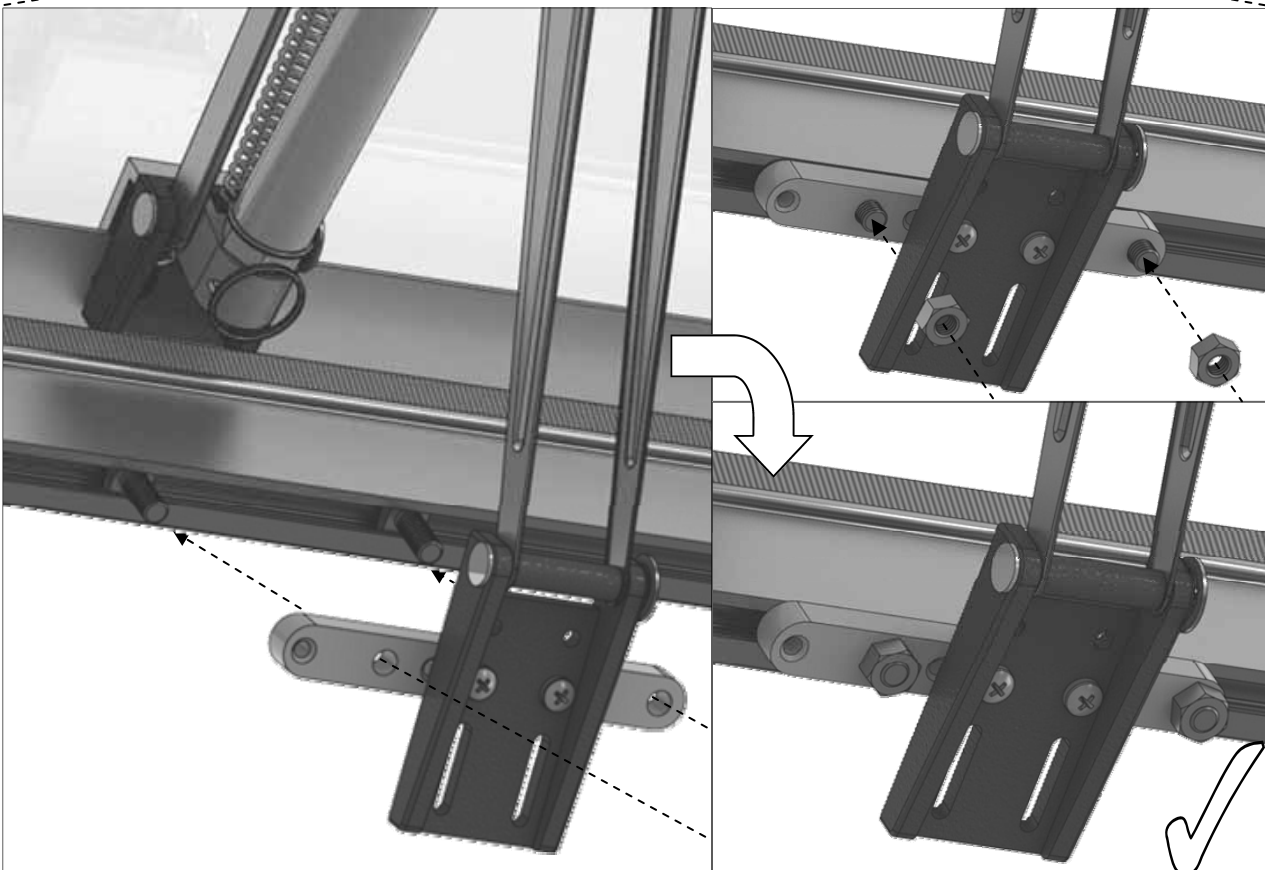
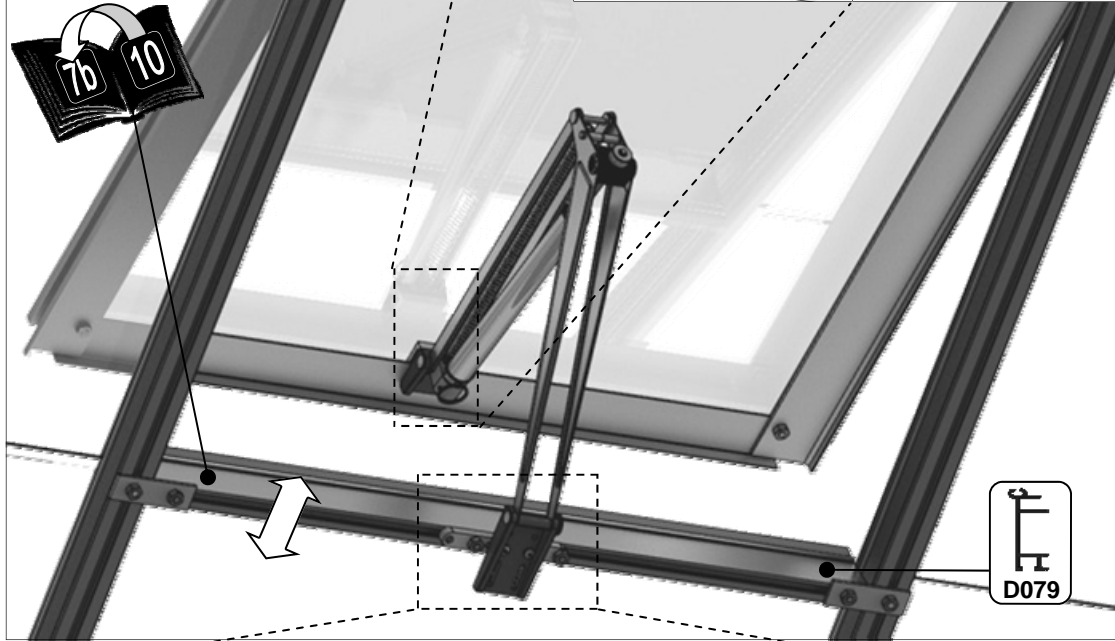
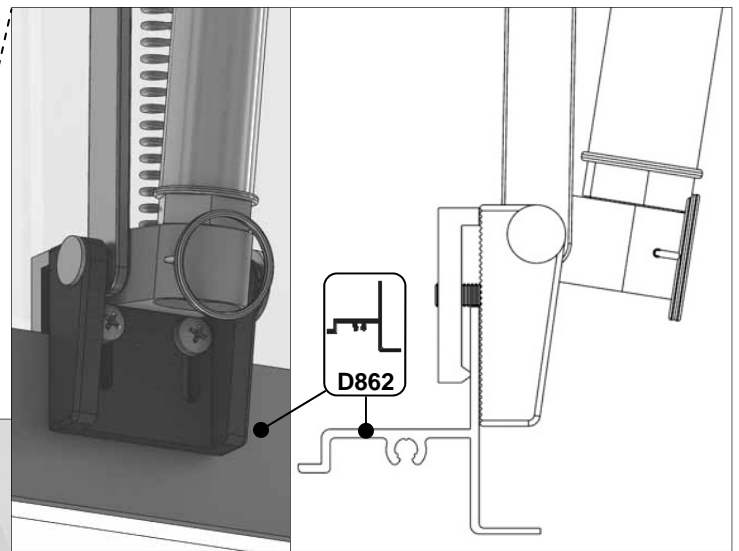
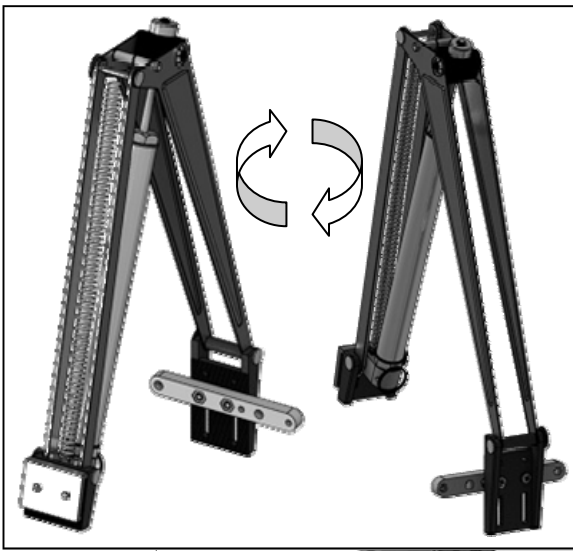



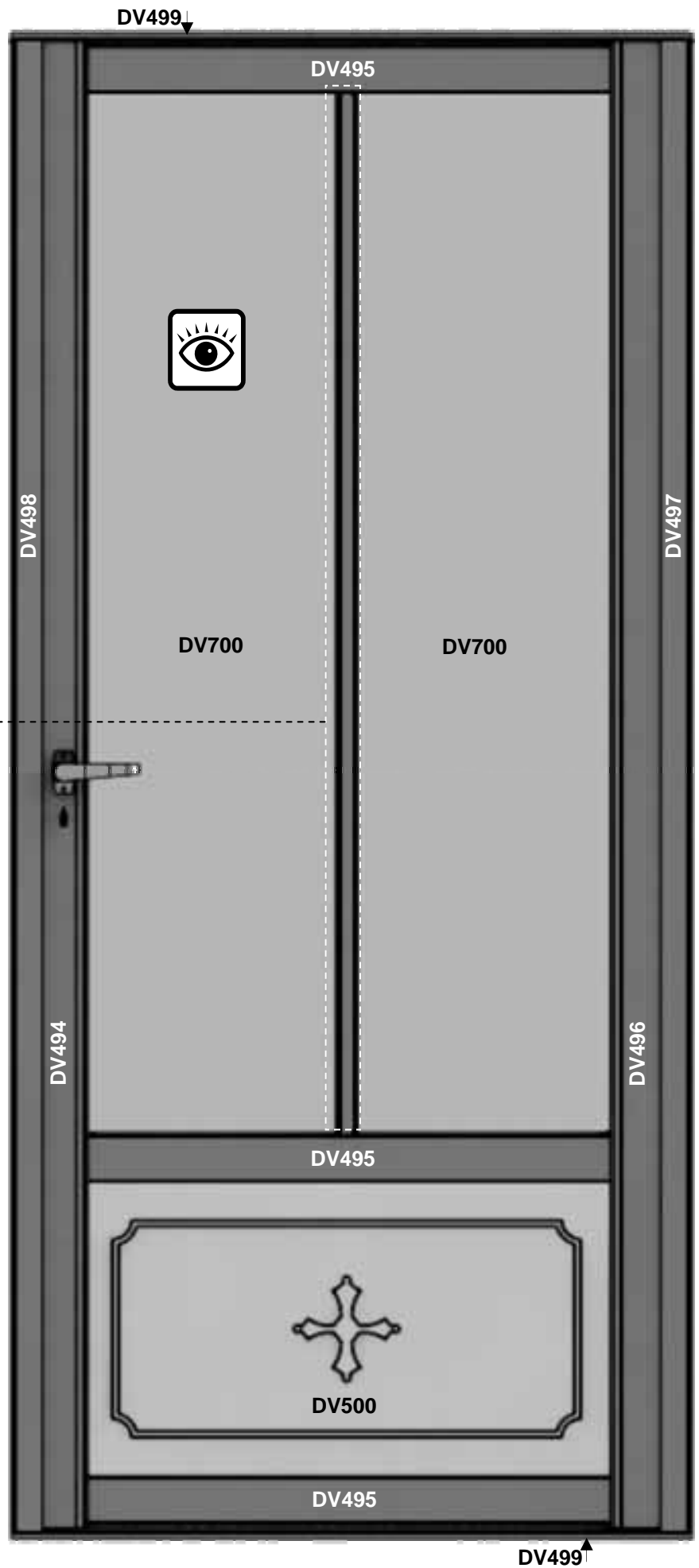
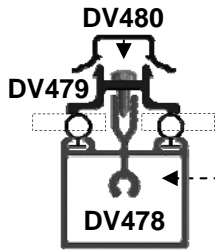
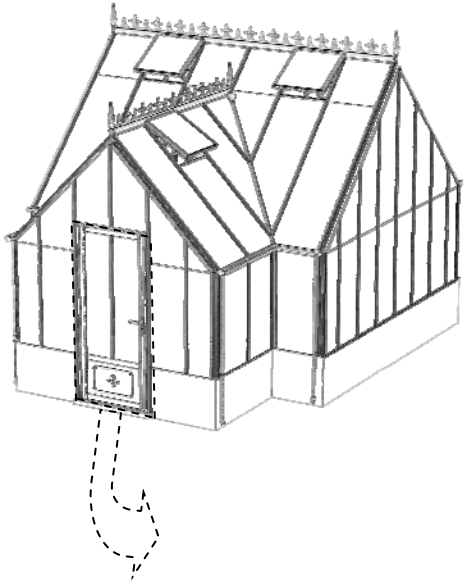

10



11

Part No		Quantity
D522		10
SYBOLM6 X11CROP		20
SYNUTM6		20

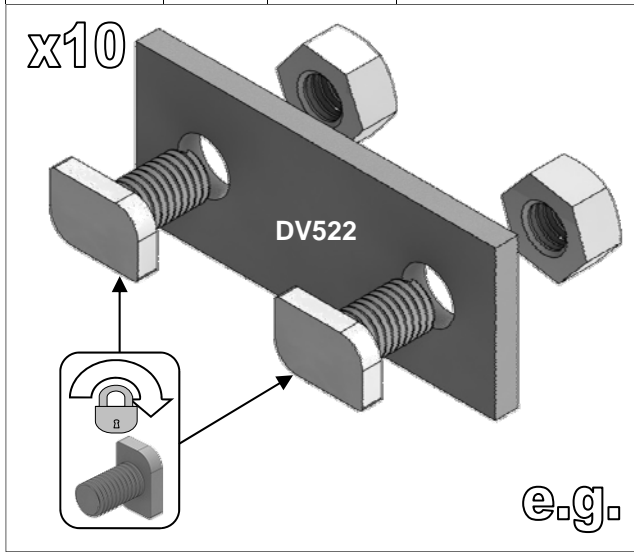

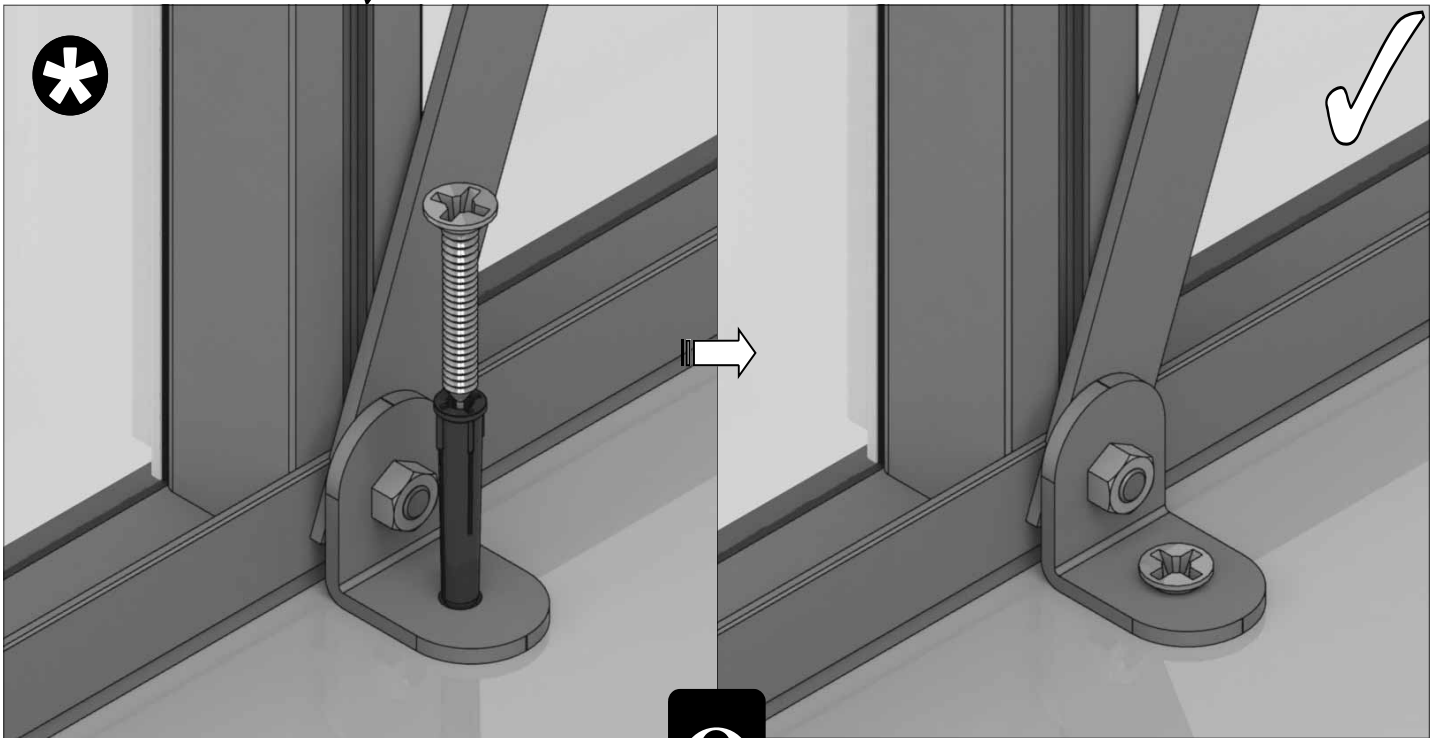
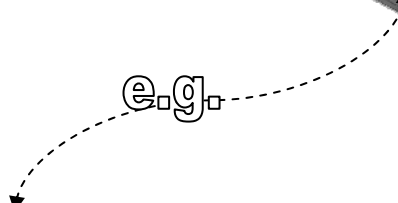
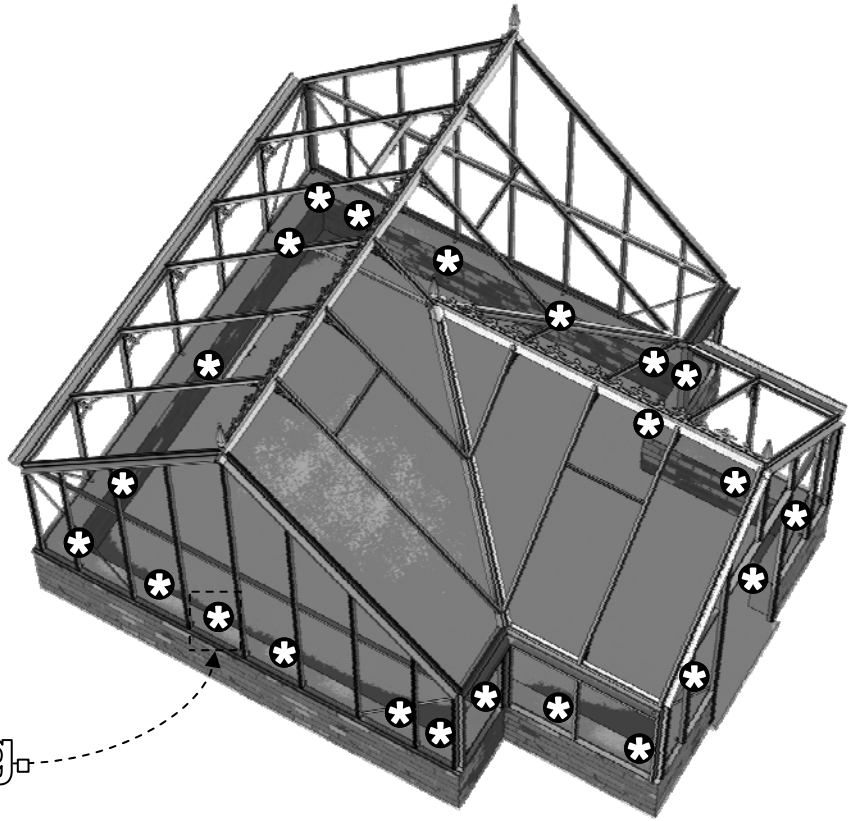
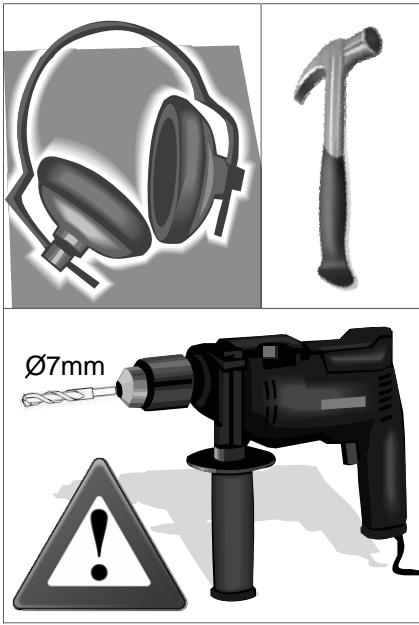

12



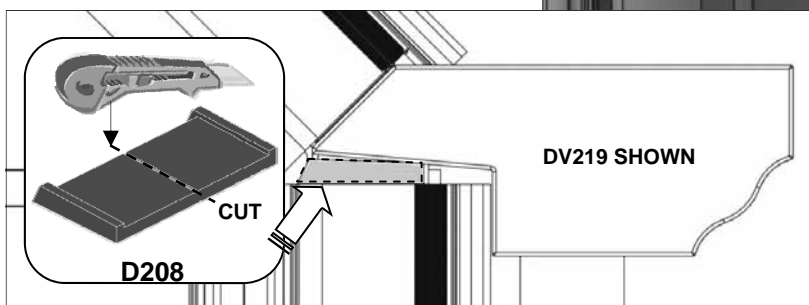
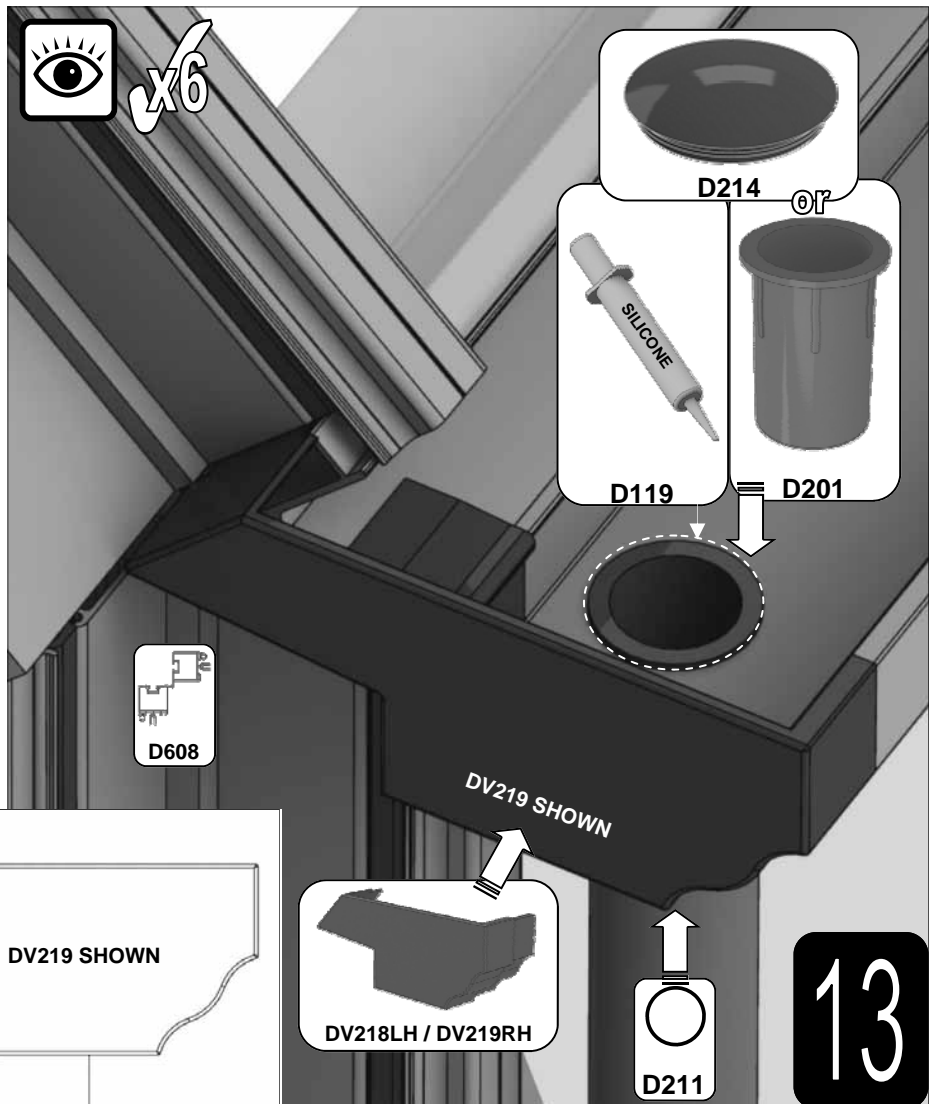
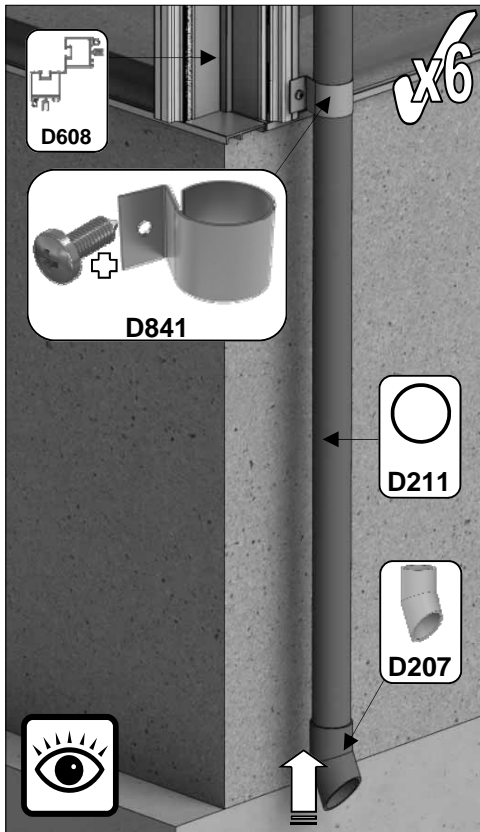
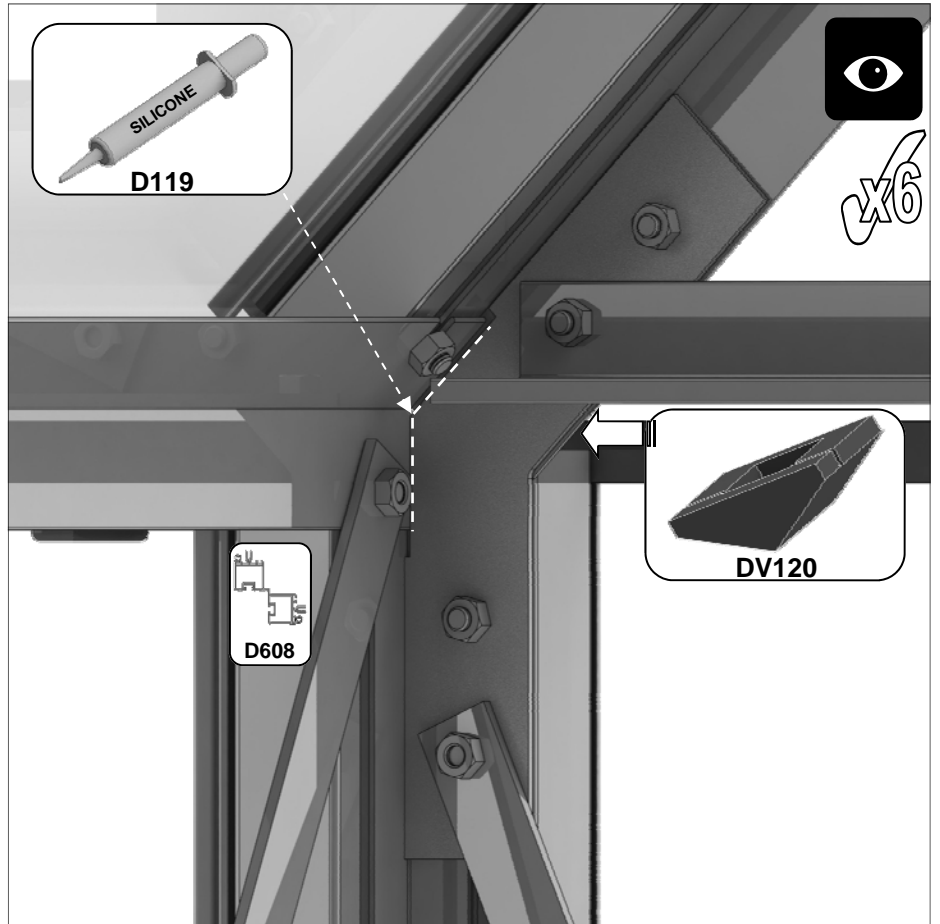
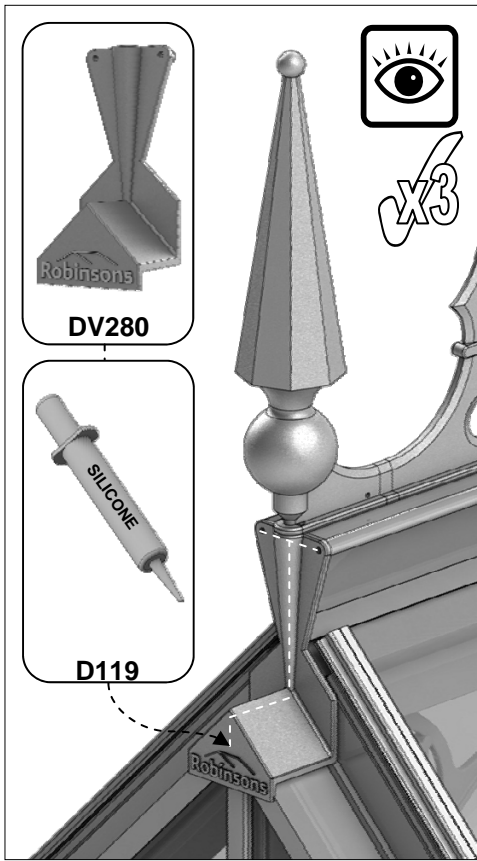

Example: 2x 4' **3** slat shelves 'ST0304' = 8' run

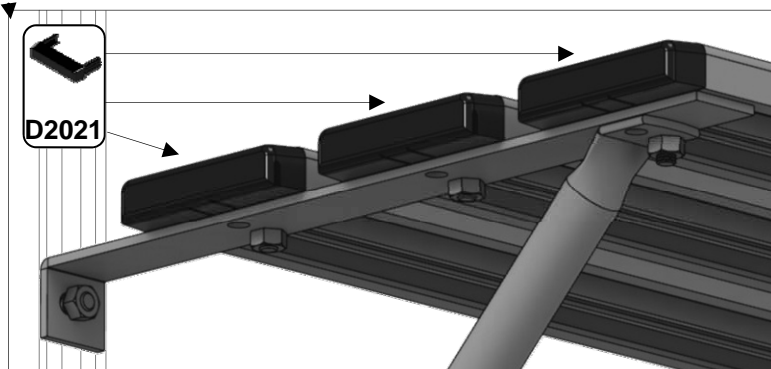
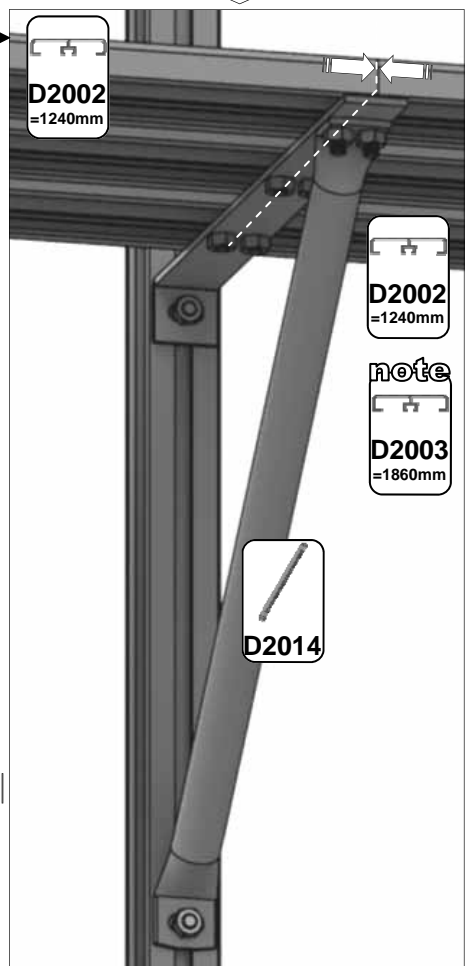
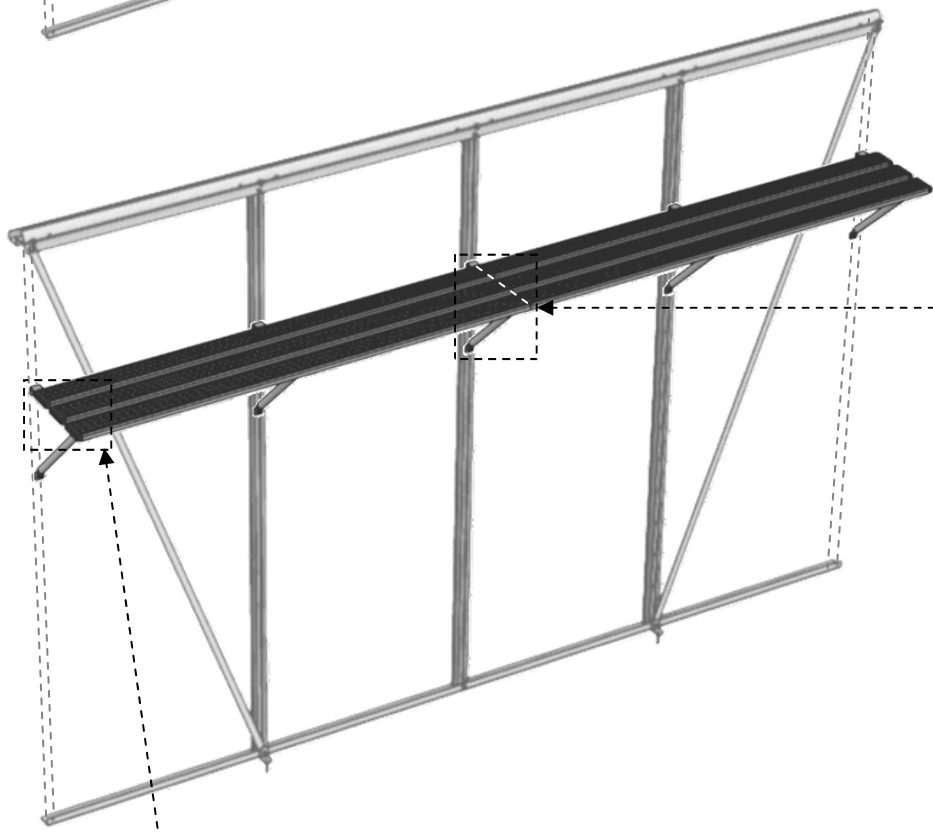
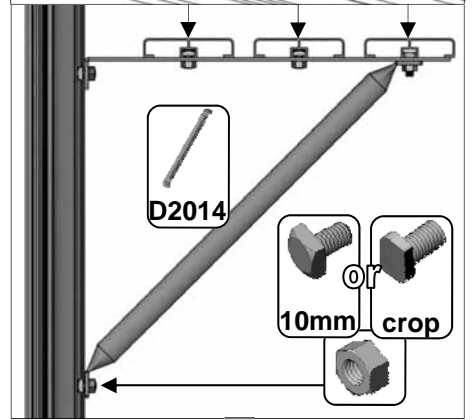
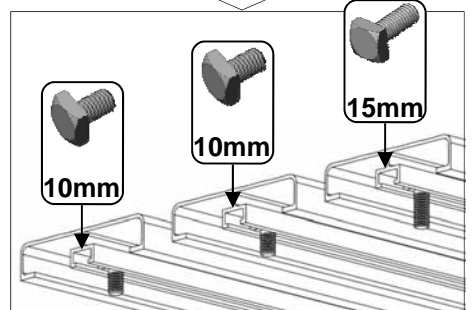
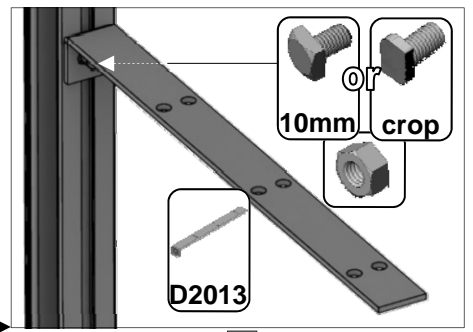
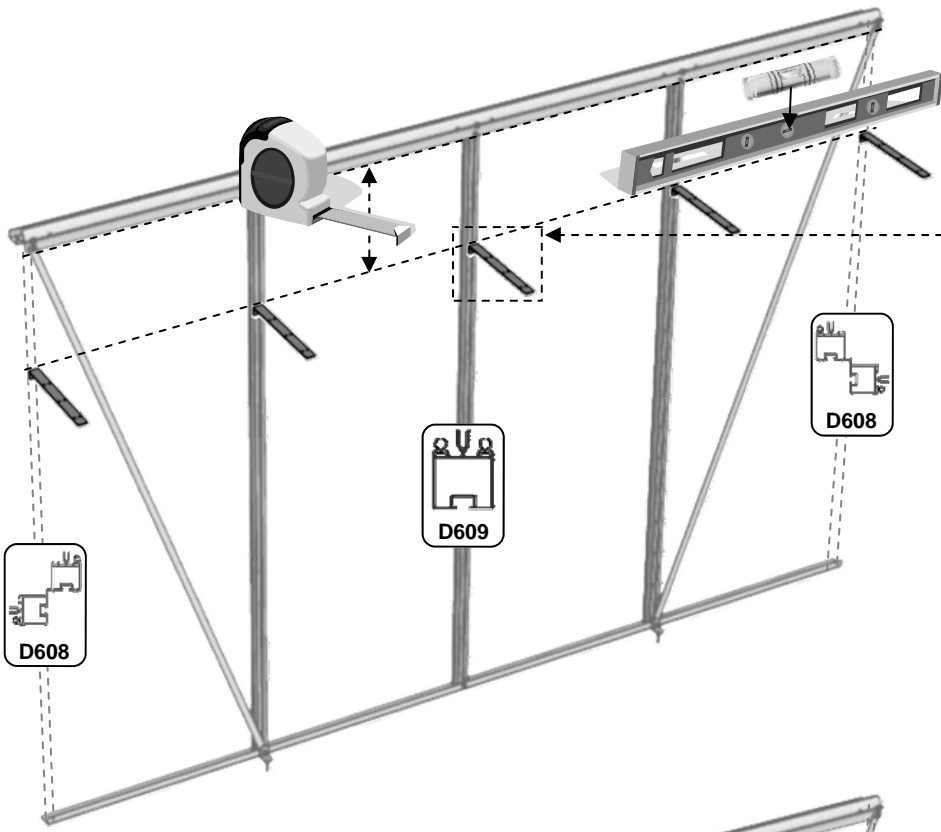

14

Example: 2x 4' **7 slat** staging 'ST0704' = 8' run

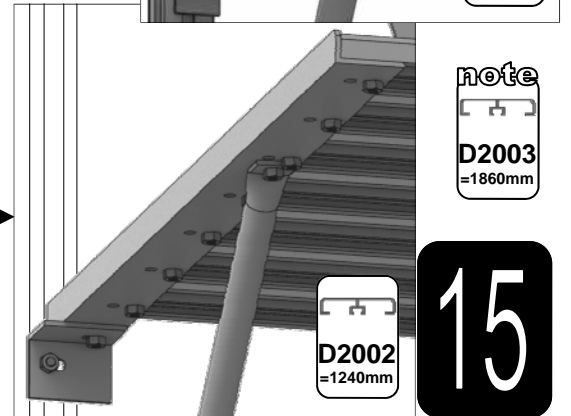
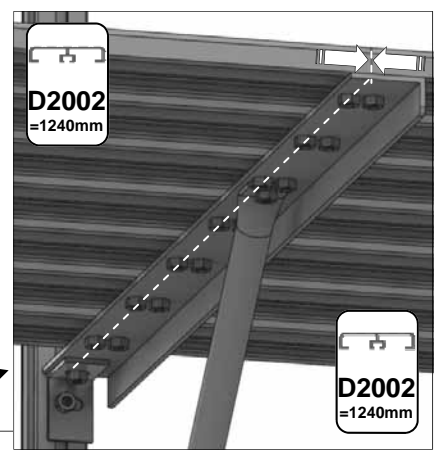
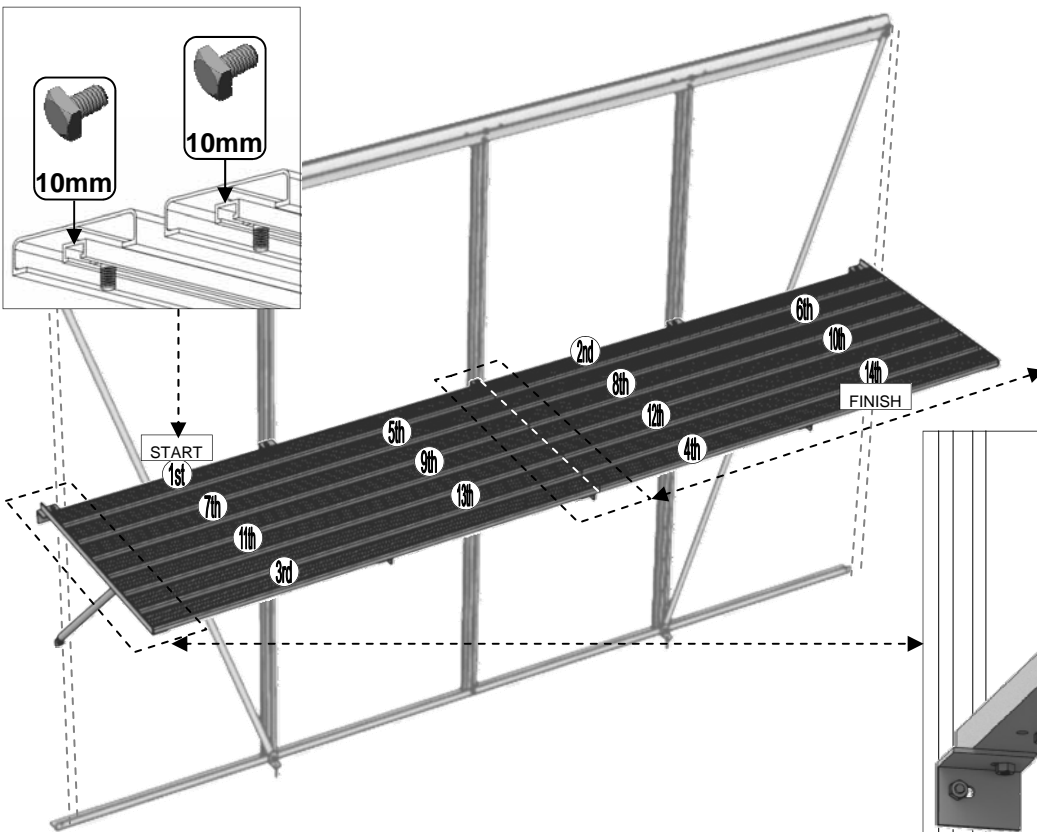
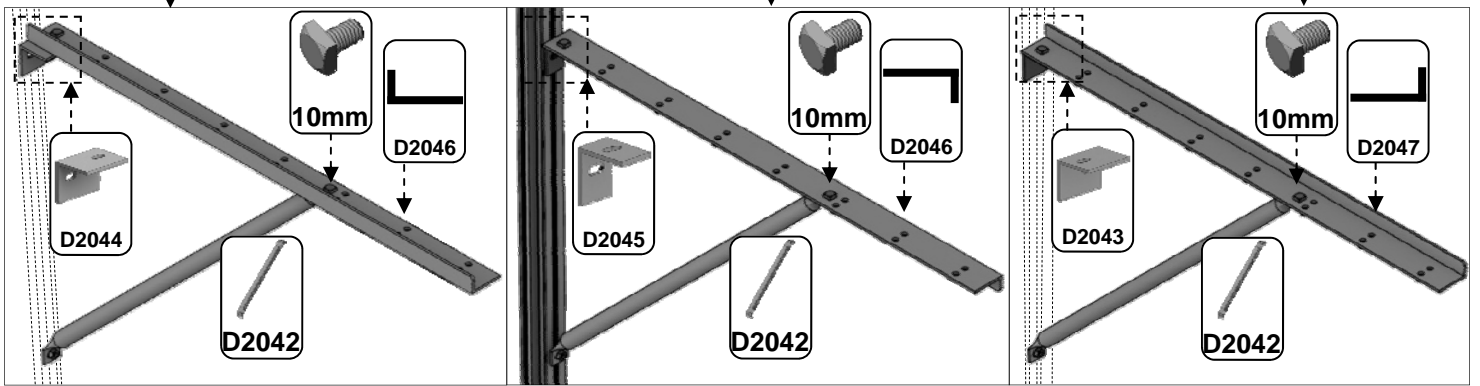
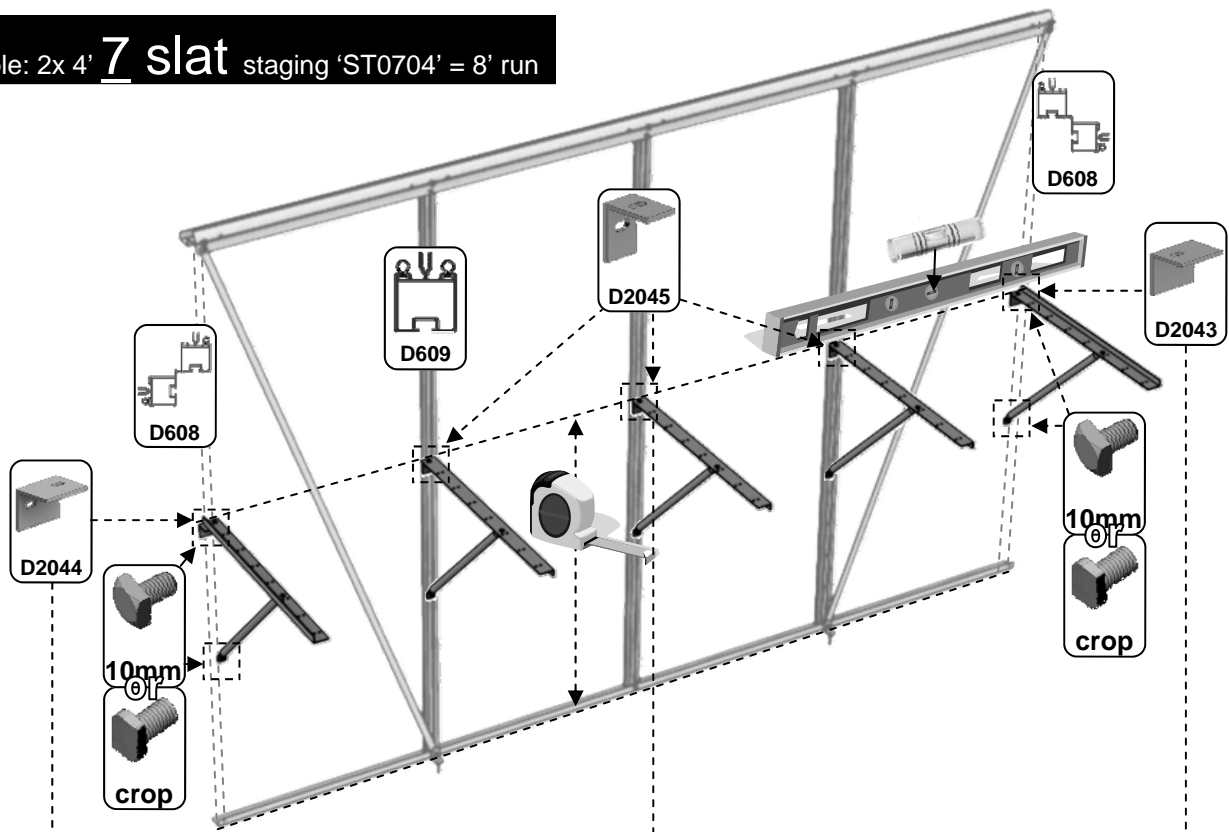

**note**  
D2003 = 1860mm

**15**

Example: 2x 4' **10** slat staging 'ST01004' = 8' run

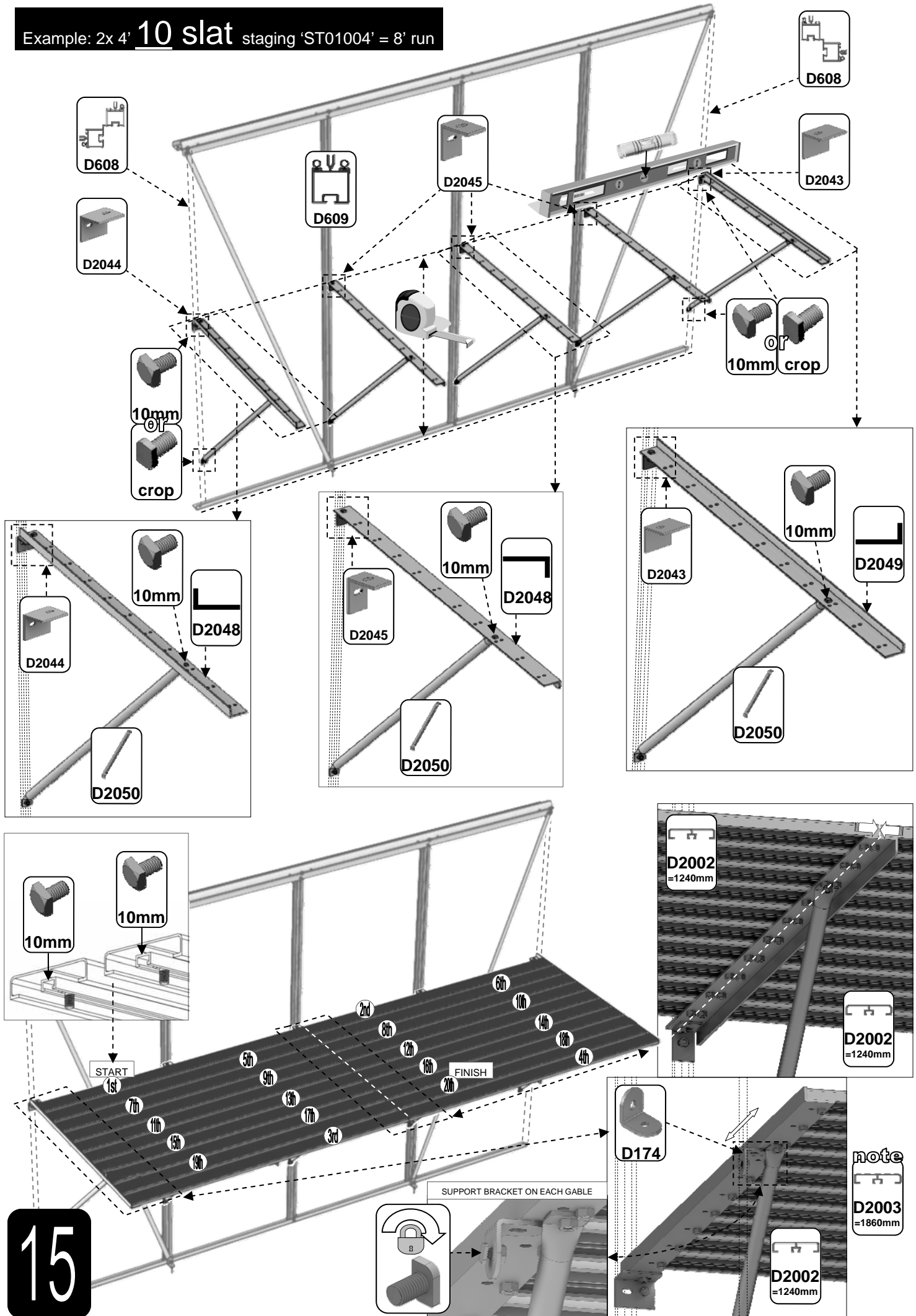

15

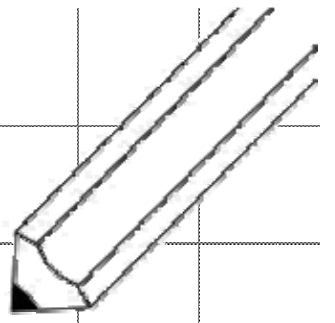

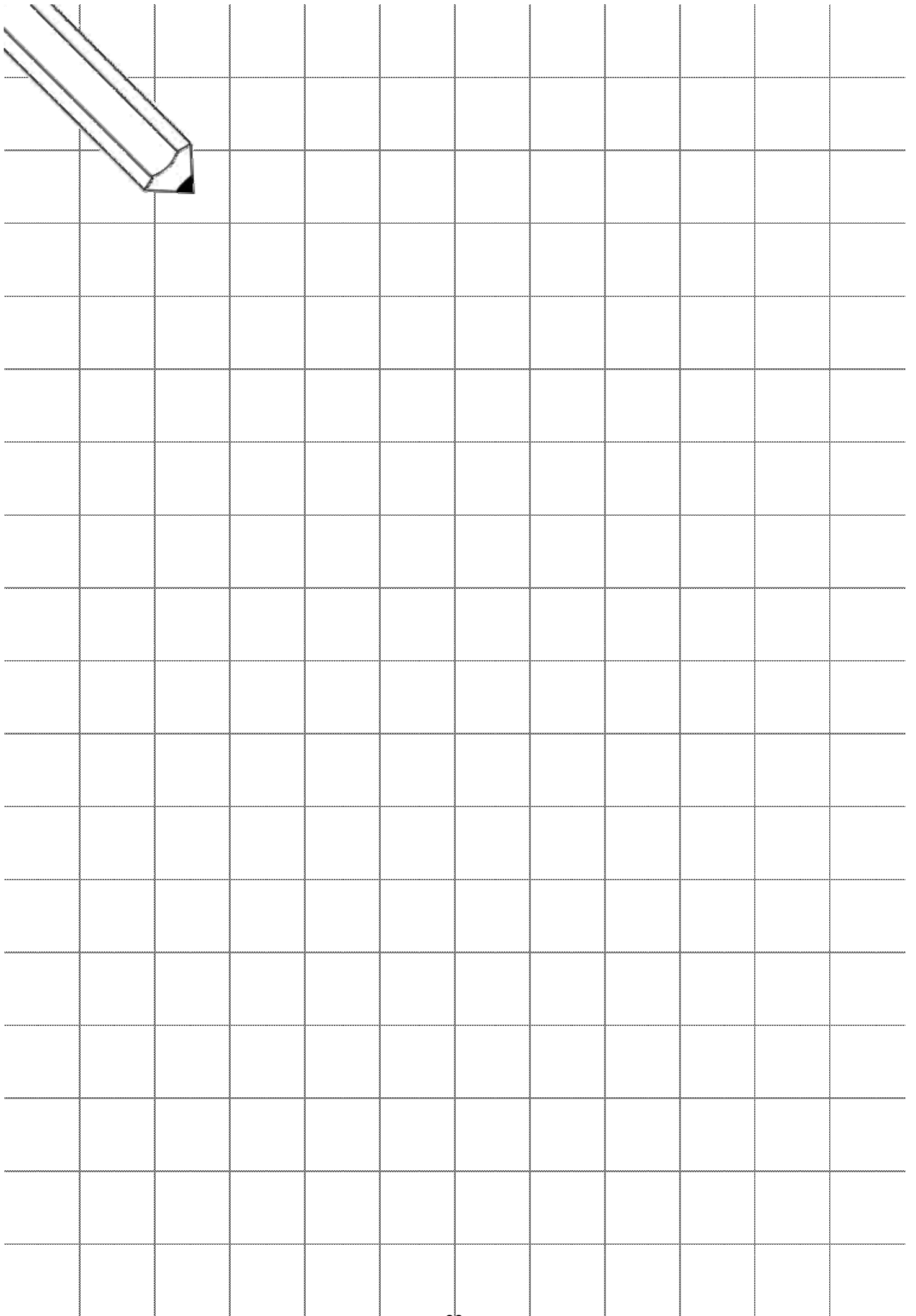
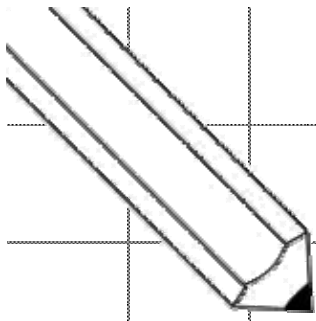

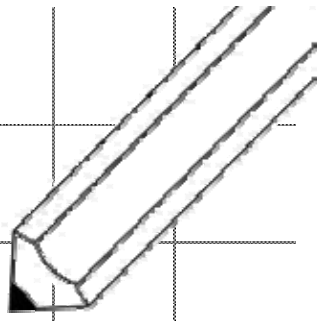



**Helpline 0116 267 7091**

**[www.birstall.com](http://www.birstall.com) [robinsons@birstall.com](mailto:robinsons@birstall.com)**