

EVOLUTION TWELVE



Cedar Greenhouses

Instruction Manual

Includes Models: 12x6, 12x8,
12x10 & 12x12



Made in the United Kingdom

Please read all instructions before proceeding

02/14



12' Wide Evolution Cedar Greenhouse Assembly Instructions

Contents:	Section	Page
Introduction	-	3
Base Preparation	1	4
Overview	2	5-6
Base Assembly	3	7
Side Assembly	4	8-9
Rear Assembly	5	10-14
Front Assembly	6	15-17
Roof Assembly	7	18-21
Louvre Assembly	8	22-23
Glazing	9	24-32
Door Installation	10	33-37
Roof Vent Installation	11	38-40
Frame Finishing	12	41
Gutter and Downpipe Installation	13	42-43
Optional Auto Louvre Installation	14	44-45
Parts Lists		46-49

Introduction

Thank you for purchasing your new Alton greenhouse. We recommend you familiarise yourself with the instructions and read all safety information before you commence assembly.

HELPLINE: 0116 267 7091

Safety Warning

- Glass, aluminium and timber can potentially cause injury. Please ensure you wear protective goggles, gloves, headgear and suitable footwear when assembling and glazing the building.
- Please remember that glass is fragile and should be handled with extreme care. Always clear up and dispose of any breakages immediately.
- Do not assemble the greenhouse in high winds.
- For safety reasons and ease of assembly, we recommend that this greenhouse is assembled by a minimum of two people.
- Please clear all lying snow from the greenhouse roof as it can cause the roof to buckle or collapse.

Site Preparation

- When selecting a site for your greenhouse, it is vital that you choose as flat and level an area as possible.
- A concrete or slabbed base will provide the most solid foundation for your greenhouse. A slabbed base would be our preferred choice as this helps with drainage.
- Avoid placing your greenhouse under trees or in other vulnerable locations.
- To minimise the risk of wind damage, try to select as sheltered a site as possible, e.g. beside a hedgerow or garden fence.

Additional Considerations

- Please bear in mind that assembling your greenhouse can be time consuming. You may need to spread the construction over two or more days. We recommend that you avoid leaving the building partially glazed. If you ever have to leave your greenhouse half assembled and not anchored down, weigh it down with slabs or bags of sand to stop the wind moving it.
- You will find it helpful to prepare a large, clean and clear area in which to work in. A garage floor or flat lawn area is ideal.
- If you have arranged for someone to install your greenhouse for you, please check that all components are included. Most parts are numbered and can be identified by a stamp or removable label. Alternatively, the components can be identified by lengths detailed in the packing list in your main cardboard box.
- Once installed your greenhouse requires little maintenance, but to maintain the smooth running of your door(s) WD40 or similar can be applied to the door wheels and lower door guides.
- Remember this is a natural un-treated product, the wood will soak up some water to start with and some staining may occur. This will settle down over time and the greenhouse will really blend with its surroundings. If you want to avoid this and give your greenhouse a more permanent finish you could apply an oil or spirit based product (it would be best to do this before glazing!).

Base Preparation

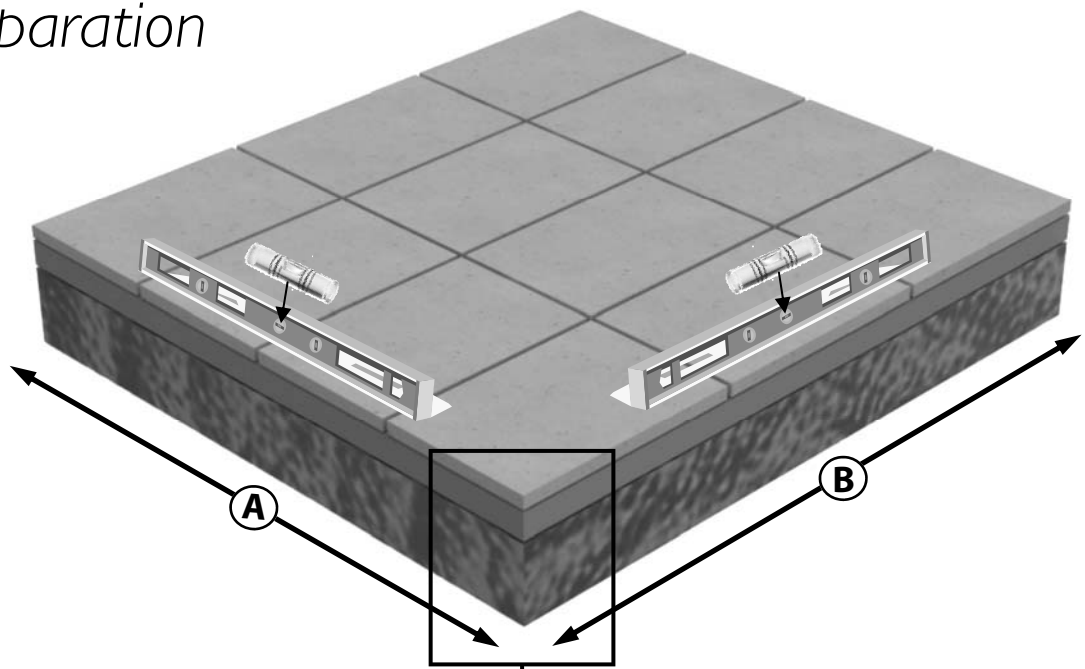

Slab Base Size (Recommended)
Note: The base should always be larger than your building.
The measurements given in 'A' and 'B' should only be used as a guide.

Greenhouse Width	Greenhouse Length	A (mm)	B (mm)
12 ft - 3877mm	6 ft - 1976mm	4270	2700
12 ft - 3877mm	8 ft - 2606mm		3600
12 ft - 3877mm	10 ft - 3236mm		3600
12 ft - 3877mm	12 ft - 3866mm		4500

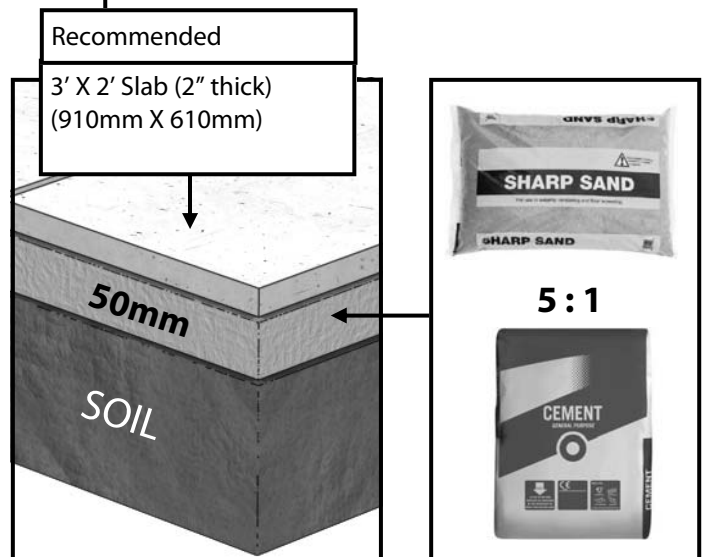

It is necessary to leave sufficient working room around your greenhouse when you're putting it up and also to allow for the possible need to replace a piece of glass in the future. If possible try and leave a space of 2ft/610mm around the greenhouse.

Locate the greenhouse where there is maximum amount of sunlight and avoid if possible any shade from trees, fences or other buildings. Over-hanging branches can be a particular nuisance and should be avoided.

Choose a site where the greenhouse is relatively easy to get to and convenient to bring water to and possibly a supply of electricity.

Finally, and most importantly, choose a site where your Alton Greenhouse will look right so that it will complement your garden.

Overview

To build your new greenhouse you will need the following tools:

Spirit Level	Pencil
PZ2 Screwdriver Bit	Cordless Screwdriver (2 would be ideal, 1 to drill and 1 to screw)
4mm Drill Bit	7mm Masonry Bit
Hammer Drill	Hammer
Step ladders	

There are 7 different types of screws used in the construction of the greenhouse. These are as follows, with examples of where to look out for them:

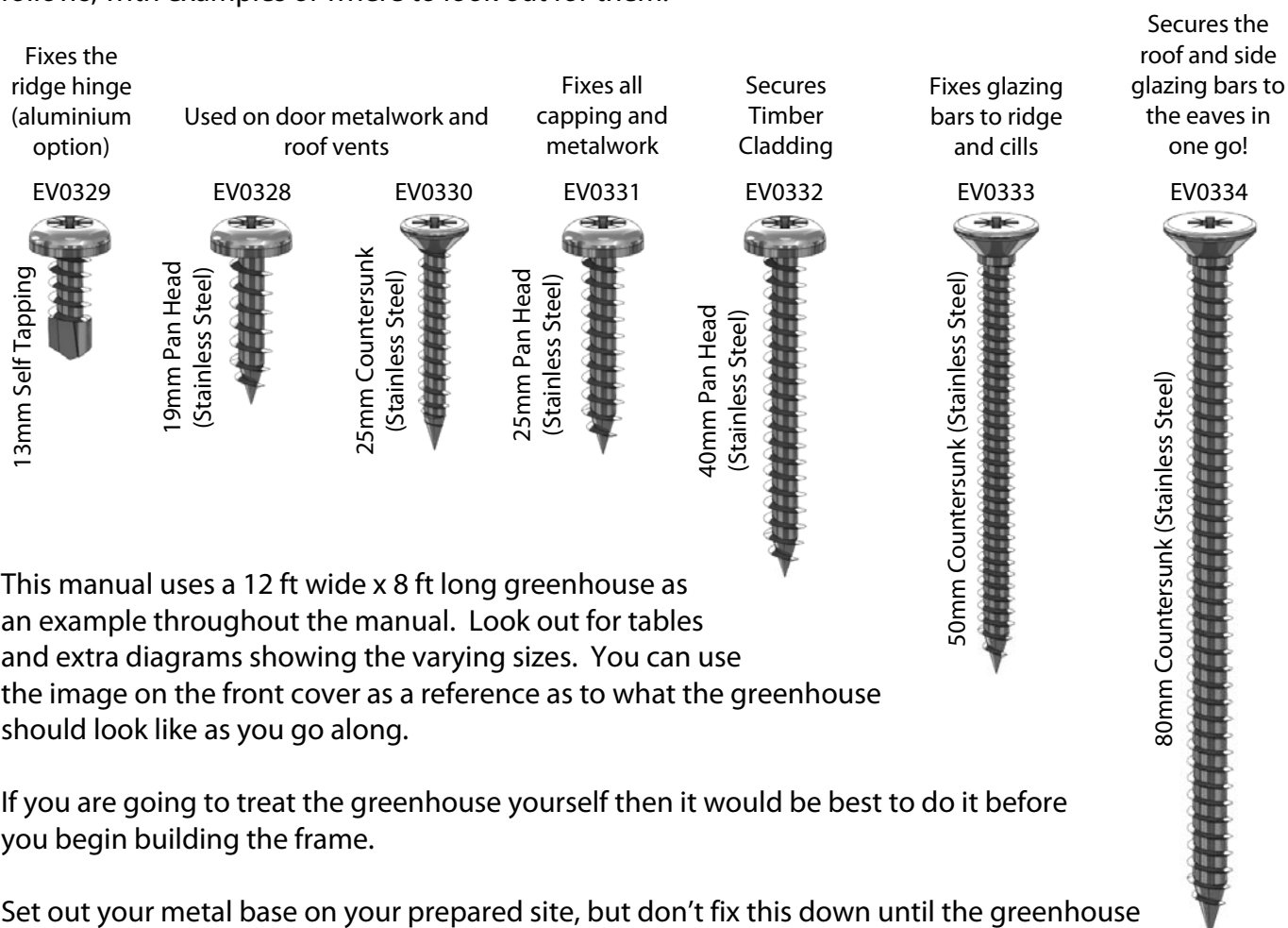

This manual uses a 12 ft wide x 8 ft long greenhouse as an example throughout the manual. Look out for tables and extra diagrams showing the varying sizes. You can use the image on the front cover as a reference as to what the greenhouse should look like as you go along.

If you are going to treat the greenhouse yourself then it would be best to do it before you begin building the frame.

Set out your metal base on your prepared site, but don't fix this down until the greenhouse is complete. Follow the manual and build the sections as recommended.

When screwing through one piece of timber into another it is always recommended to predrill the first piece. This will prevent the timber from splitting which could weaken the structure.

You can build the sides flat on the ground and then with help or using a prop position the first one ready for installation. You then work your way around the greenhouse connecting each section. The rear gable is the next section to install, followed by the other side and then the front gable. Once you have completed the gables and sides you can install the ridge and the roof.

Overview

Glazing the structure is very simple but be very careful of the edges of the glass as the pane will break into tiny peaces if you catch an edge on a hard surface such as concrete. You should also wear suitable gloves when handling the glass (this also helps to keep it clean). It is good practice to pre-load the bar capping with screws and position this around the greenhouse ready for you when you arrive with the glass.

During glazing you will also need to fit the louvre vents so make sure you have these built and ready to slot in. These fit between 2 pieces of glass and are held in place by the capping system.

Take time over fitting the door track and bottom runner as this will be most noticeable if you don't get it right. This is the one part of the building you will touch and use regularly.

Then fit the roof vent. This is done from the inside, gain access through the opening on a set of steps.

All you have left to do now is fit the gutter and downpipes, think about where you might site a waterbutt when doing this.

Extension and Partition instructions are in separate booklets. Be sure to follow these instructions at the correct time in the build. For an extension this will be during the initial stages before you build the front end. The partition can be added while constructing the roof. If you have a partition and an extension remember the partition can **not** be positioned at the join of your main building and the extension.

You can always add a Partition or an Extension at a later date so consider this when you are siting your greenhouse.

Option of gluing joints. This is not required for strength but you may do it if you wish. However bare in mind if you ever intend to move or adapt the greenhouse in the future this would make it very difficult. The best glue for this would be Poly Urethane Wood Adhesive. Take care when applying this, you only need a very small amount as the glue expands to fill the joint. If you use too much it may seep out of the joint and could be unsightly! Try a test piece before you start.

Read through the rest of this manual before starting, you are less likely to miss something doing this and you will have a better understanding of how it all works.

Base Assembly

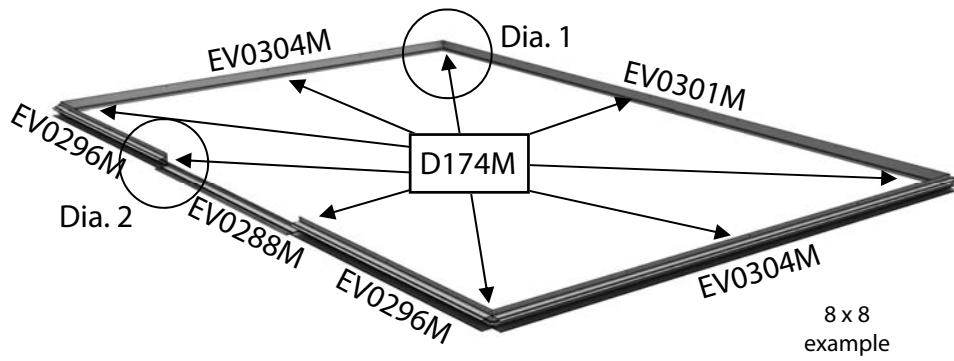

Lay out your aluminium base sections as the diagram shows. Insert bolts in the bolt channels for attaching the base brackets (HE300), diagram 1. The base brackets should always be positioned either side of the door, in the corners, in the middle of the rear and equally spaced down the sides. Use the joining bracket in each corner to join the sections (diagram 1). The top holes will take

a 25mm screw when the side cills are fixed to it. Also fit the front door cill with 2 plates (HE512M), diagram 2.

Look for the length of building you have in the table below to check what you should be using.

NB. For Extensions refer to separate manuals.

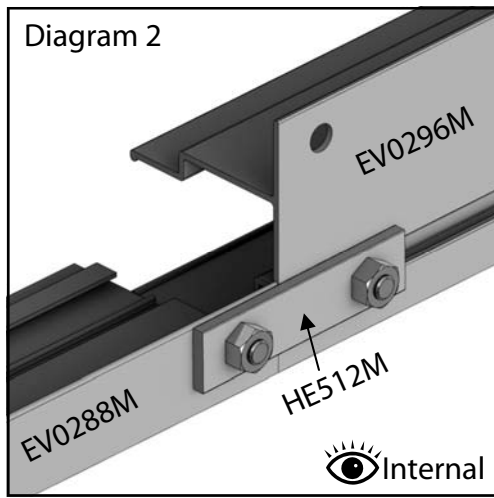
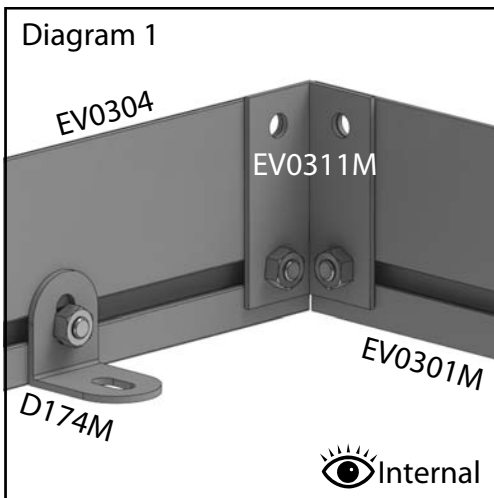

6ft			
Part Name	Part Number	Size (mm)	Qty
Front	EV0296M	1283	2
Side	EV0303M	1846	2
Rear	EV0301M	3779	1
Door Cill	EV0288M	1216	1
Joining Bracket	EV0311M	-	4
Base Bracket	D174M	-	9
Plate	HE512M	-	2

8ft example			
Part Name	Part Number	Size (mm)	Qty
Front	EV0296M	1283	2
Side	EV0304M	2476	2
Rear	EV0301M	3779	1
Door Cill	EV0288M	1216	1
Joining Bracket	EV0311M	-	4
Base Bracket	D174M	-	9
Plate	HE512M	-	2

10ft			
Part Name	Part Number	Size (mm)	Qty
Front	EV0296M	1283	2
Side	EV0305M	3106	2
Rear	EV0301M	3779	1
Door Cill	EV0288M	1216	1
Joining Bracket	EV0311M	-	4
Base Bracket	D174M	-	11
Plate	HE512M	-	2

12ft			
Part Name	Part Number	Size (mm)	Qty
Front	EV0296M	1283	2
Side	EV0306M	3736	2
Rear	EV0301M	3779	1
Door Cill	EV0288M	1216	1
Joining Bracket	EV0311M	-	4
Base Bracket	D174M	-	11
Plate	HE512M	-	2

Side Assembly

To start building your greenhouse begin by laying out the components for your sides flat on the ground like the diagram below. Use the tables below to identify your building length and the components with the part numbers and sizes. First of all drill pilot holes through the bottom of each mortise on the cill section (diagram 3, page 9). Then slot each glazing bar into the mortise holes. These are designed as a tight fit so you may need help with this or maybe use a solid object to push against. Once firmly in position fix with the 50mm screw. Now slot the eaves rail into position (e.g. EV0021). There is no need to fix this yet as it is done at a later stage.

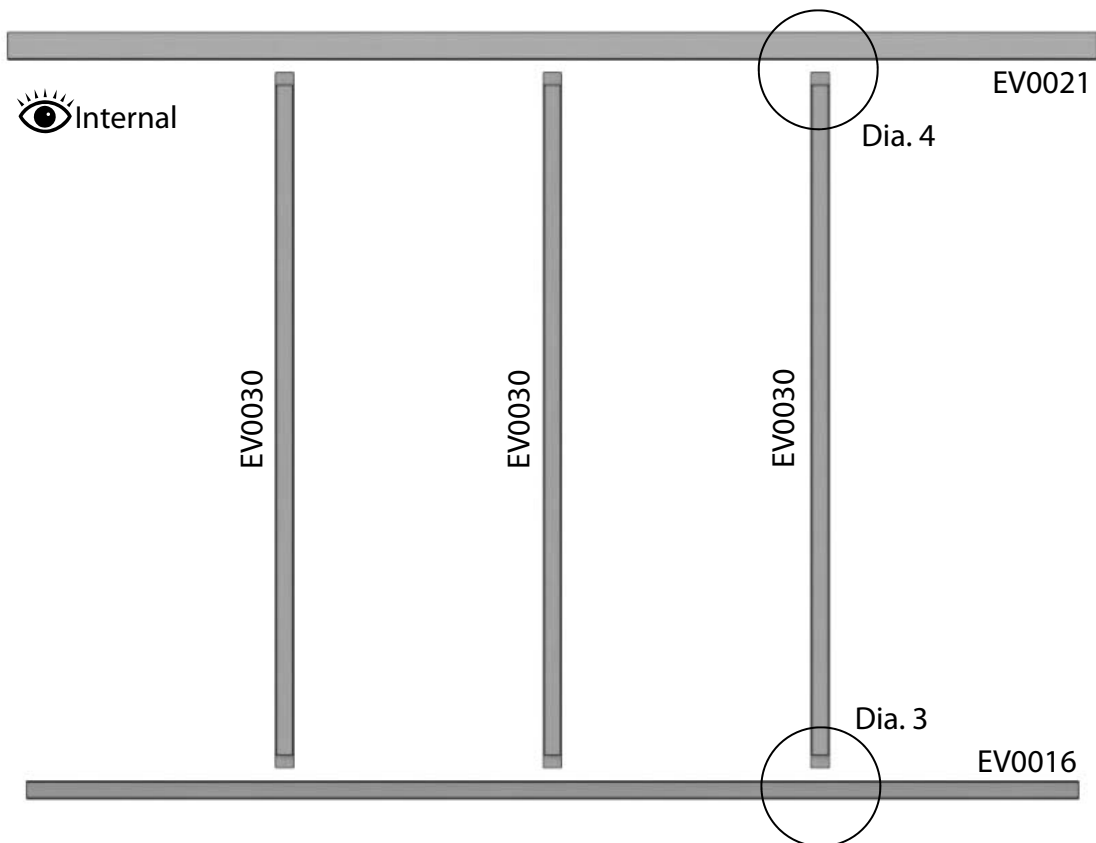

4ft				6ft				8ft example			
Part Name	Part Number	Size (mm)	Qty	Part Name	Part Number	Size (mm)	Qty	Part Name	Part Number	Size (mm)	Qty
Cill	EV0014	1216	2	Cill	EV0015	1846	2	Cill	EV0016	2476	2
Eaves Bar	EV0019	1304	2	Eaves Bar	EV0020	1934	2	Eaves Bar	EV0021	2564	2
Glazing Bar	EV0030	1588	2	Glazing Bar	EV0030	1588	4	Glazing Bar	EV0030	1588	6

10ft				12ft			
Part Name	Part Number	Size (mm)	Qty	Part Name	Part Number	Size (mm)	Qty
Cill	EV0017	3106	2	Cill	EV0018	3736	2
Eaves Bar	EV0022	3194	2	Eaves Bar	EV0023	3824	2
Glazing Bar	EV0030	1588	8	Glazing Bar	EV0030	1588	10

Side Assembly

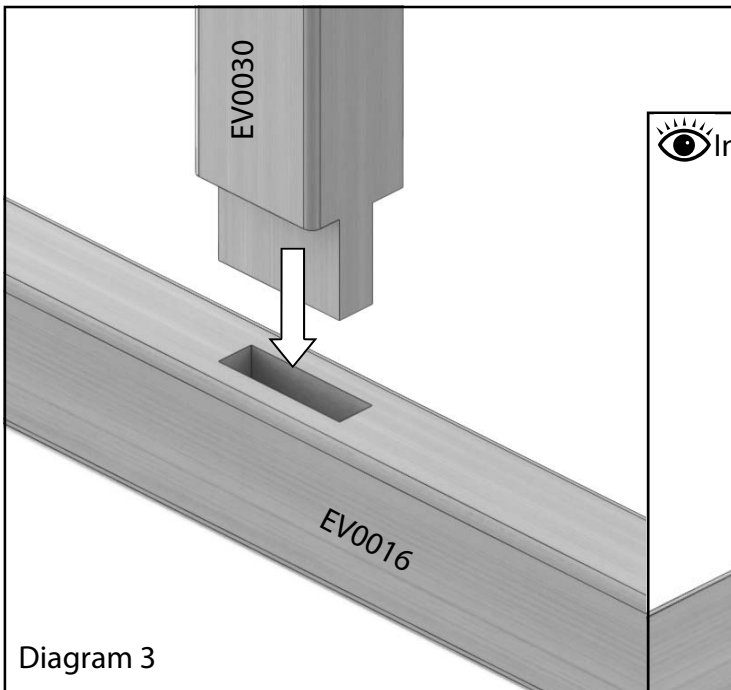

Diagram 3

Make sure the side bars are pushed all the way in, you may find they need a light tap with a wooden mallet or something similar.

(If you are going to glue your joints this is the first point you would do this.)

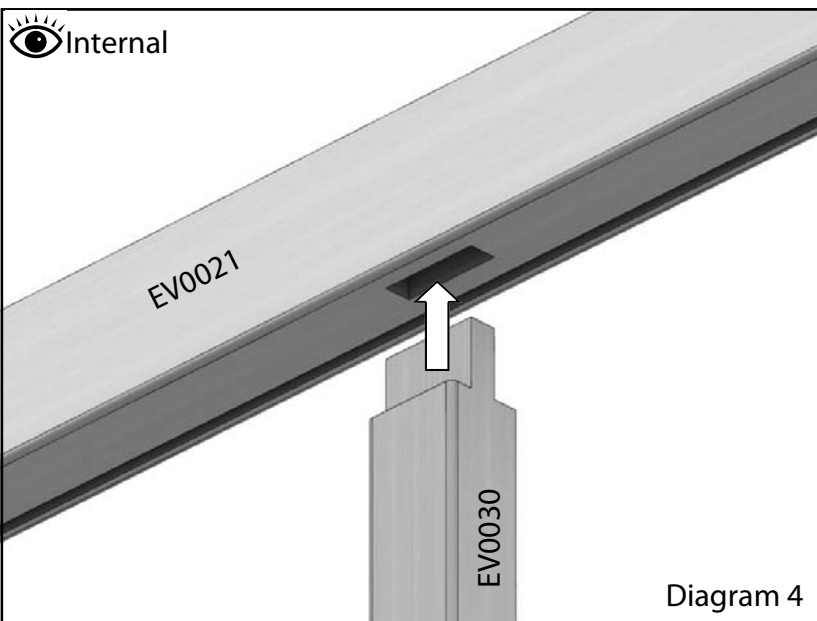
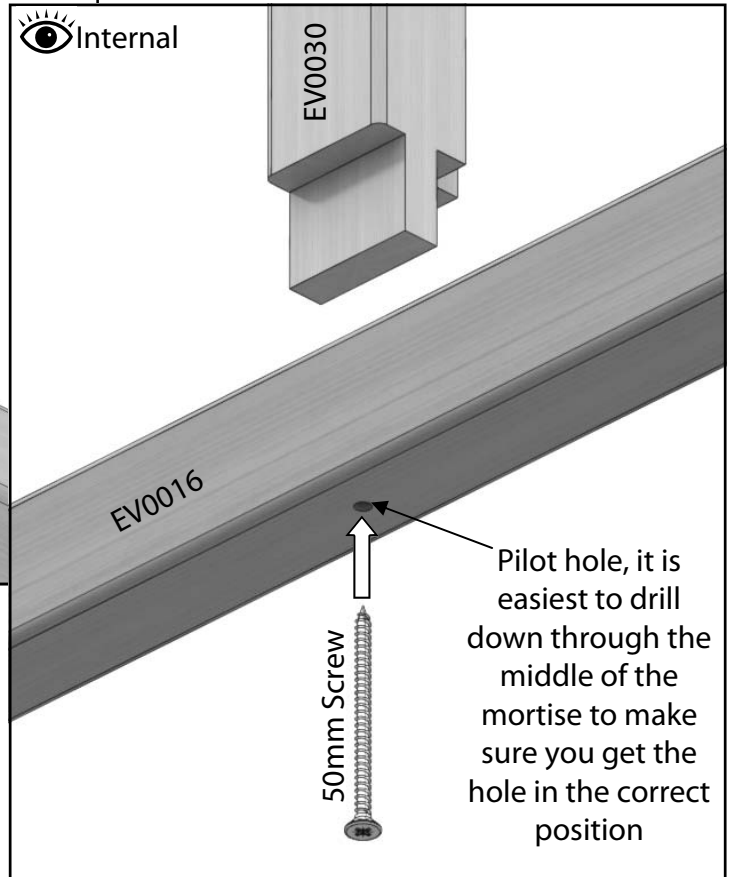
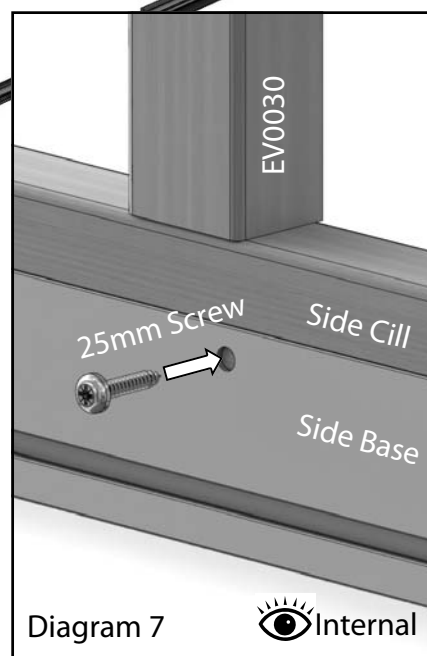
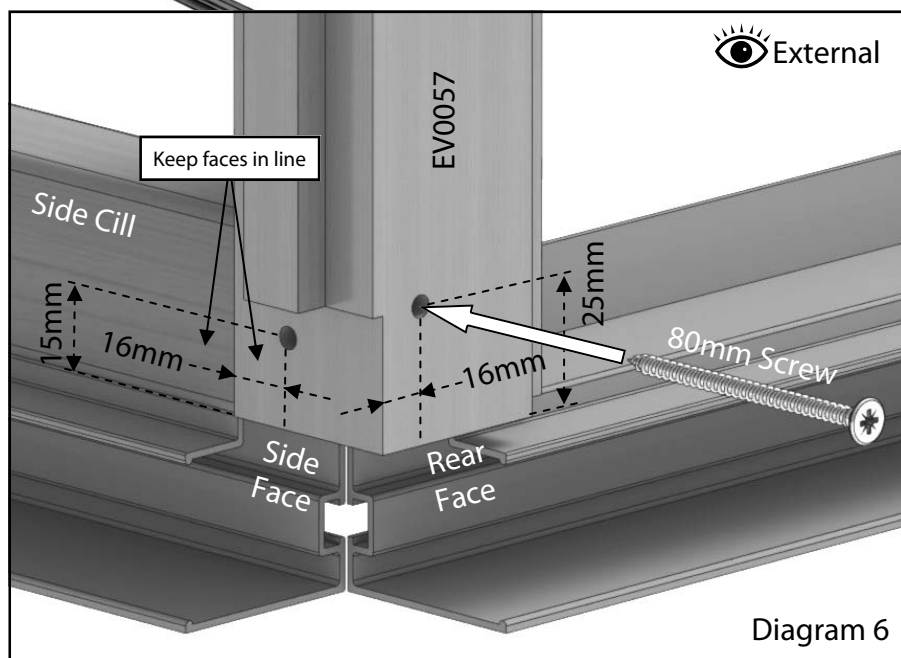
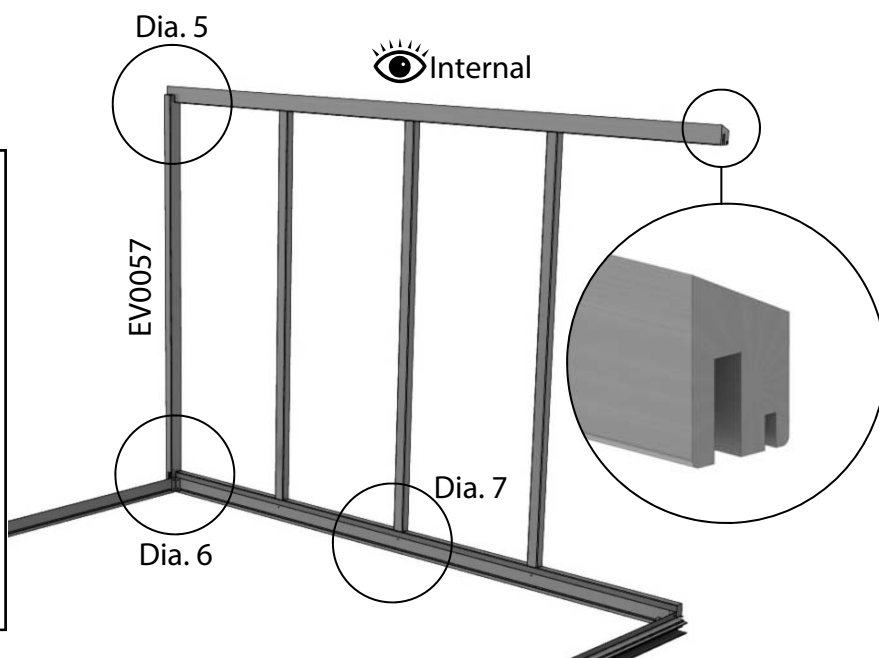
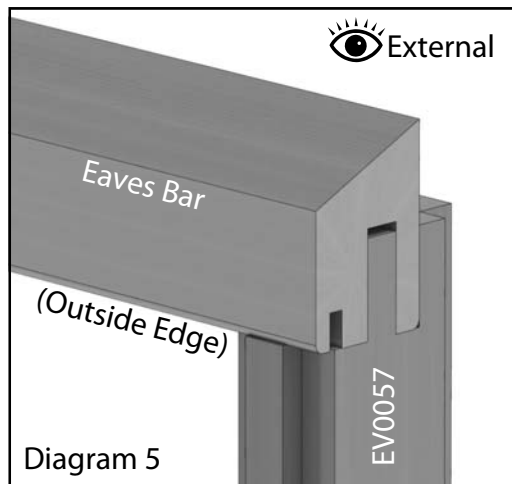

Diagram 4

Rear Assembly



To install this section you will need a helper to hold the side in position or strap it to a set of steps. Drill two pilot holes in the bottom of the side corner bar as in diagram 6. The height of these holes should be about 15mm on the side face and 25mm on the rear face measured from the end of the bar, try to keep these at different heights to each other so the screws don't intersect each other.

Now offer the side corner to the eaves bar slotting the tennon into the mortise shown in diagram 5, do not fix this joint as it will be done at a later stage. Screw the bottom of the corner glazing bar to the end of the cill (80mm screw) making sure the rebate for the glass lines up with the front face of the side cill (diagram 6).

Once the side corner bar is in place this will give you the correct position on the aluminium base and you can fix the base to the side cill with 25mm screws (diagram 7).

Rear Assembly

Locate the rear cill and rear gable glazing bars (these are different to the front gable glazing bars as they do not have the mortise for the door header).

Start by drilling pilot holes in the cill section through the mortise holes as before (diagram 8). Also drill 2 holes in the top of the gable glazing bars through the lap joint location. These should be 25-30mm apart and the first hole should be a similar distance from the very top edge (see right)

Assemble the gable glazing bars with the rear cill flat on the ground as you did with the side sections.

Again with the aid of a helper or using a prop position the rear end onto the aluminium base. Locate the end of the cill into the mortise on the side corner bar (diagram 9, page 12).

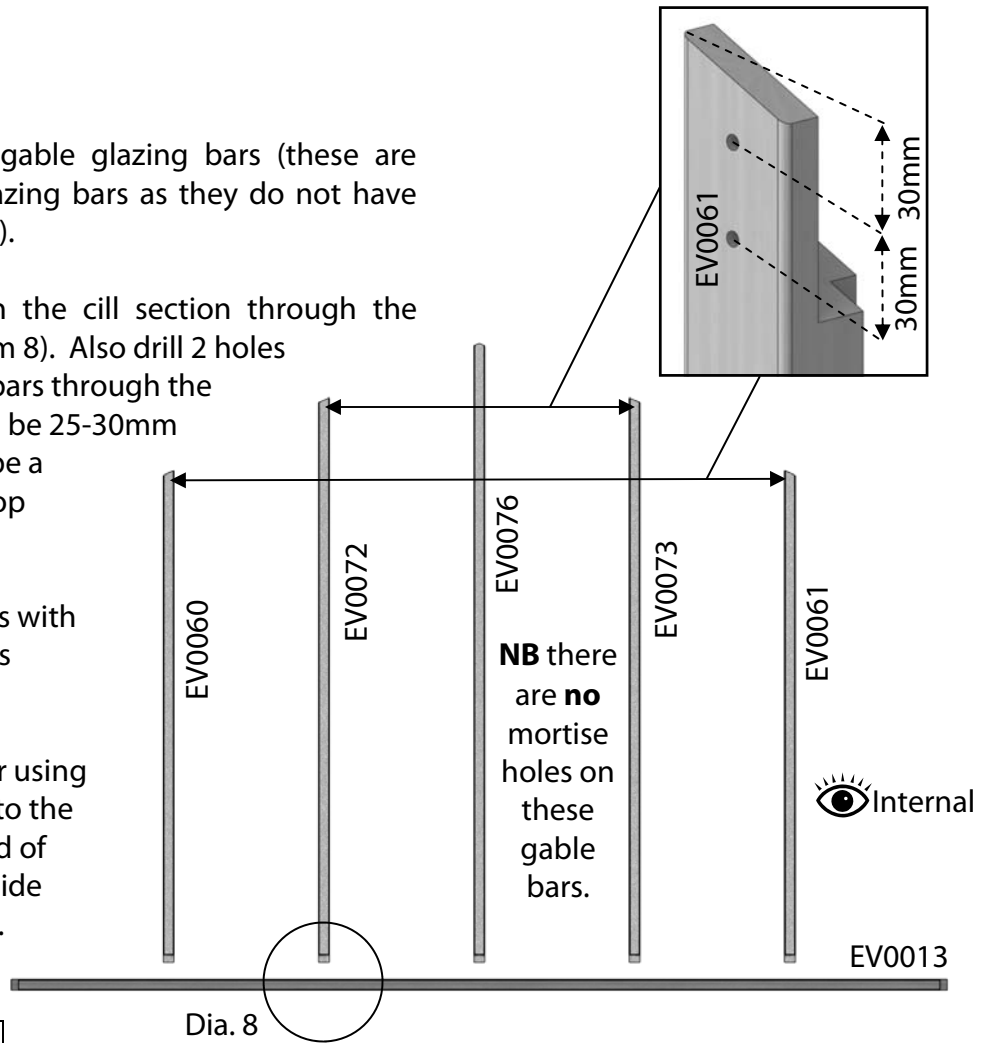

12ft Rear			
Part Name	Part Number	Size (mm)	Qty
Cill	EV0013	3796	1
Roof Corner R	EV0044	2153	1
Roof Corner L	EV0045	2153	1
Side Corner R	EV0056	1650	1
Side Corner L	EV0057	1650	1
Gable Bar R	EV0060	1994	1
Gable Bar L	EV0061	1994	1
Gable Bar R	EV0064	2288	1
Gable Bar L	EV0065	2288	1
Mid Gable Bar	EV0076	2502	1

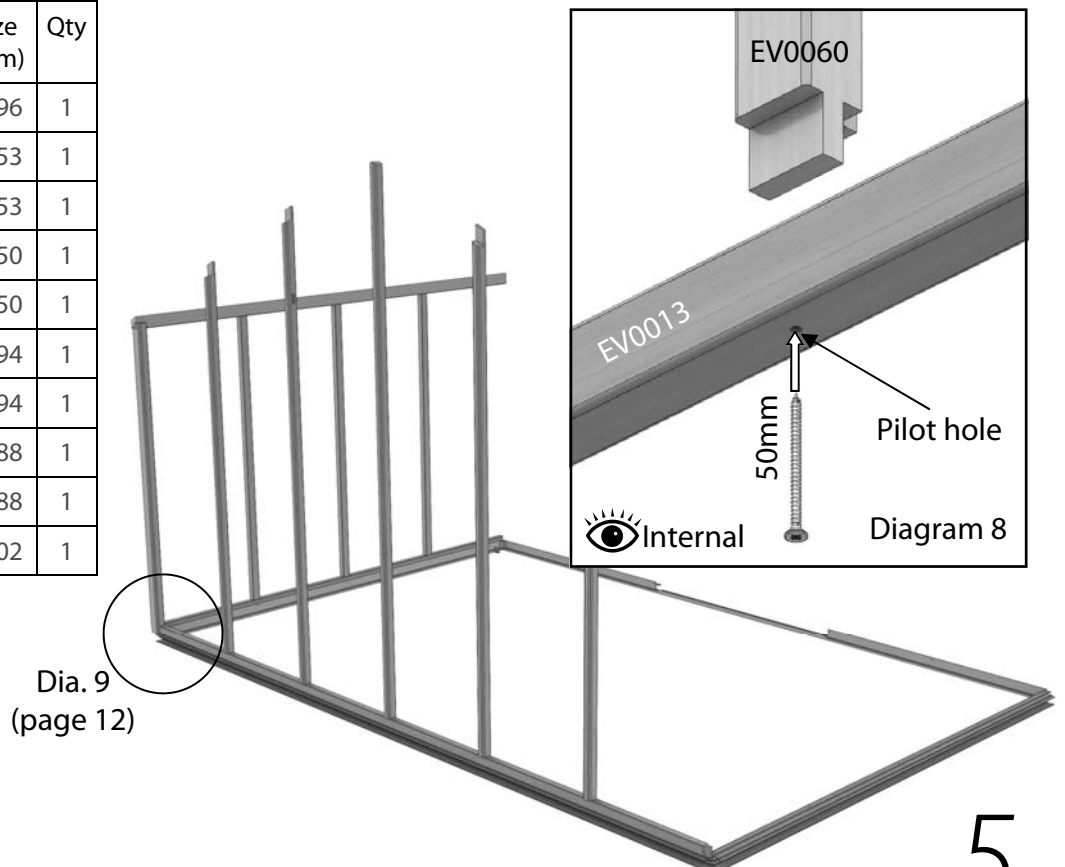

Rear Assembly

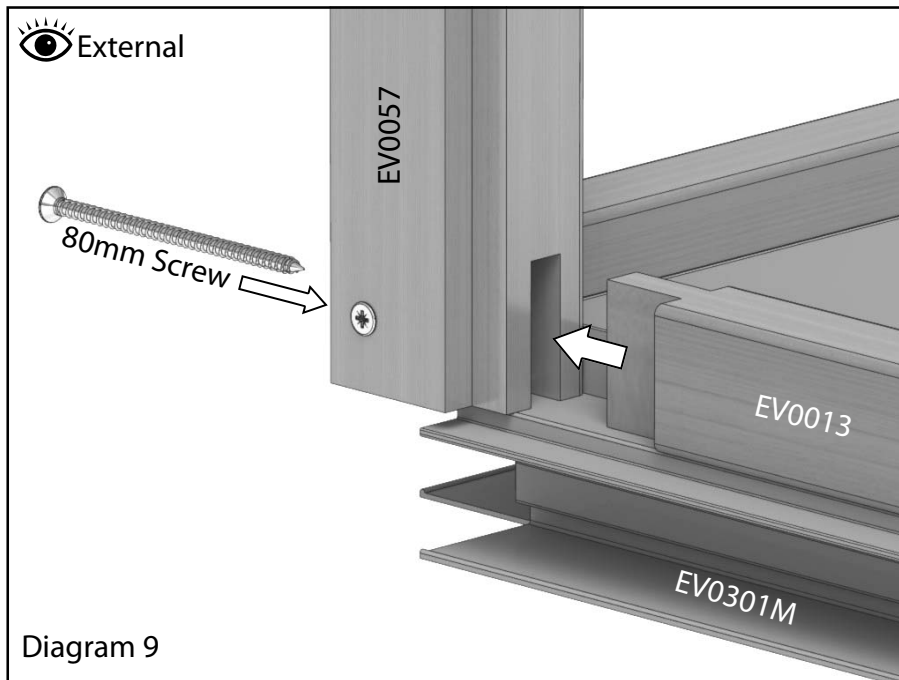

Once you have fixed the joint with the 80mm screw (diagram 9) fix the rear cill to the aluminium base with 25mm screws.

You can now install the first roof corner bar. Position the notched end onto the eaves bar (diagram 11). Next locate the lap joint at the top of the gable glazing bar. First of all secure the lap joint with two 40mm screws through the pilot holes you drill previously (diagram 10).

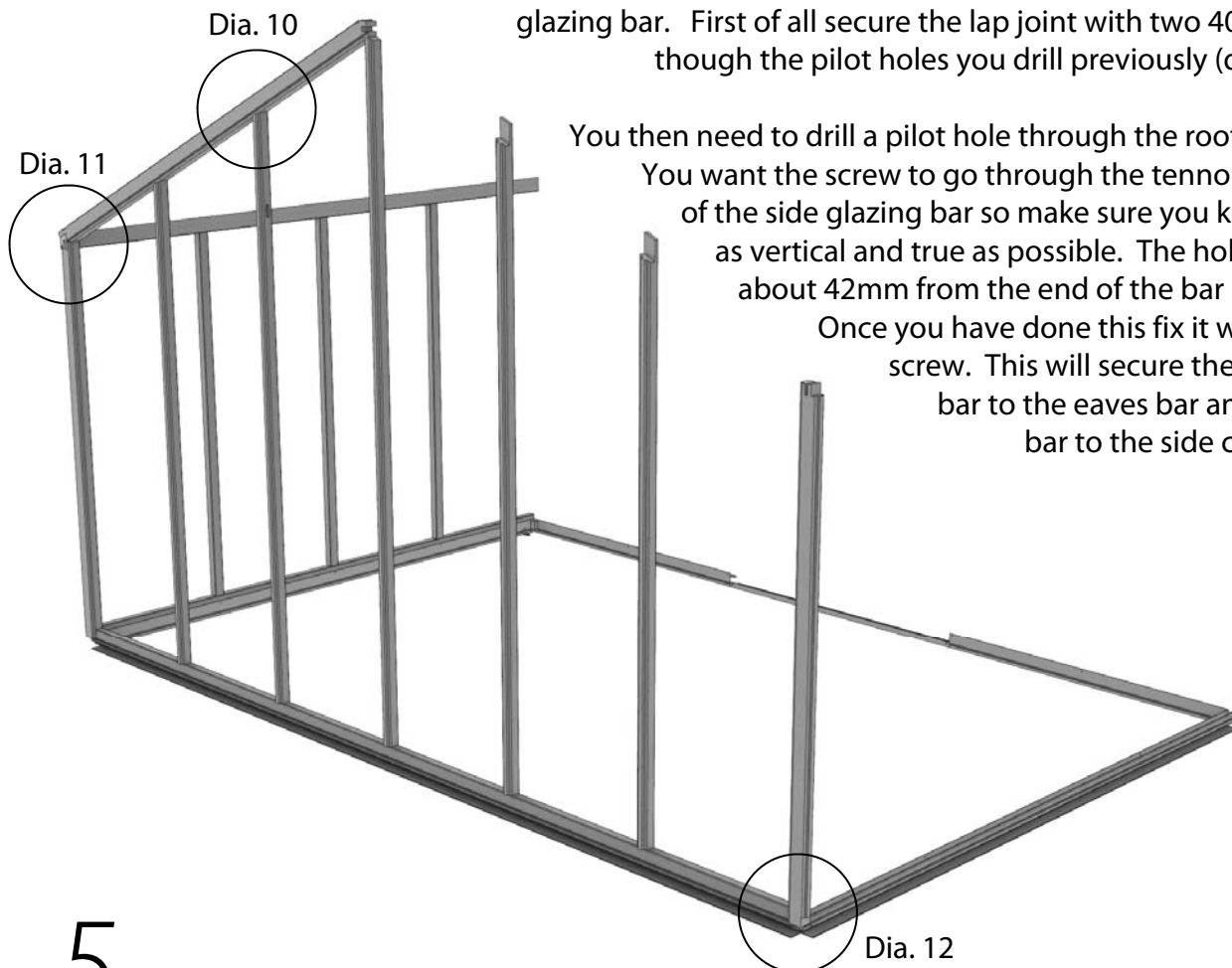

You then need to drill a pilot hole through the roof corner bar. You want the screw to go through the tennon in the end of the side glazing bar so make sure you keep the drill as vertical and true as possible. The hole should be about 42mm from the end of the bar (diagram 9).

Once you have done this fix it with a 80mm screw. This will secure the roof corner bar to the eaves bar and the eaves bar to the side corner bar in one go.

Rear Assembly

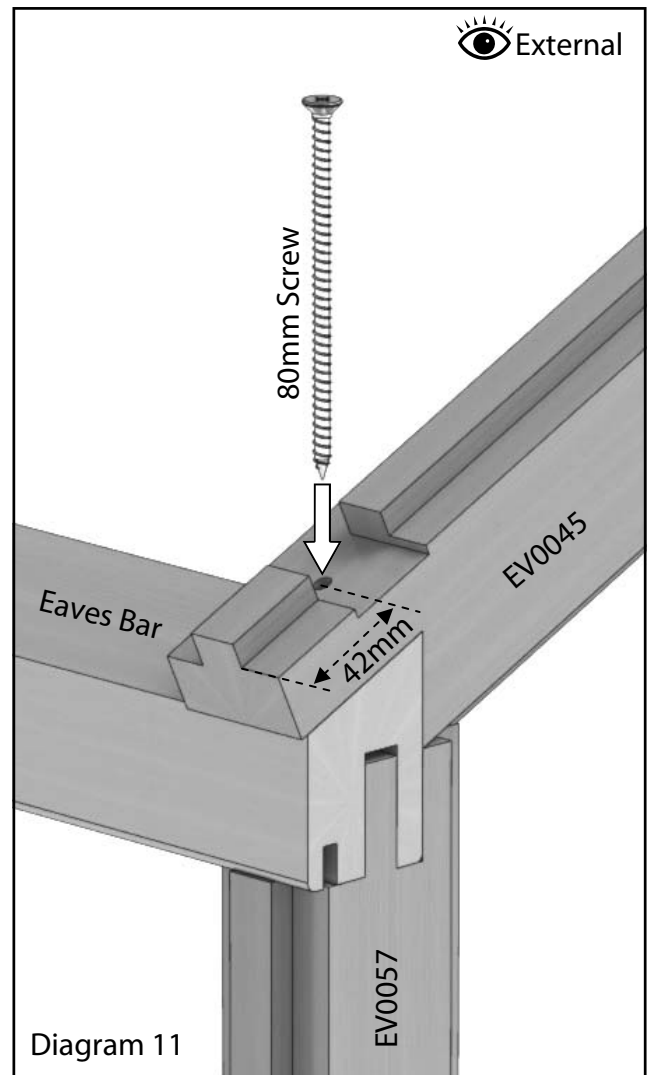
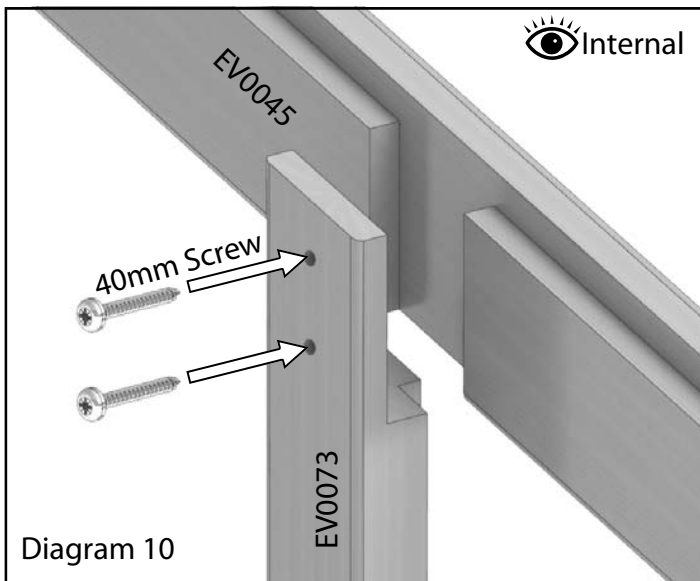

Now fit the right hand corner bar. Drill 2 pilot holes in the bottom of the bar (diagram 12). See diagram 6 for the position of these holes. Fit the side bar over the tennon of the rear cill and fix it with the 80mm screw. You can then also screw the base to this with a 25mm screw.

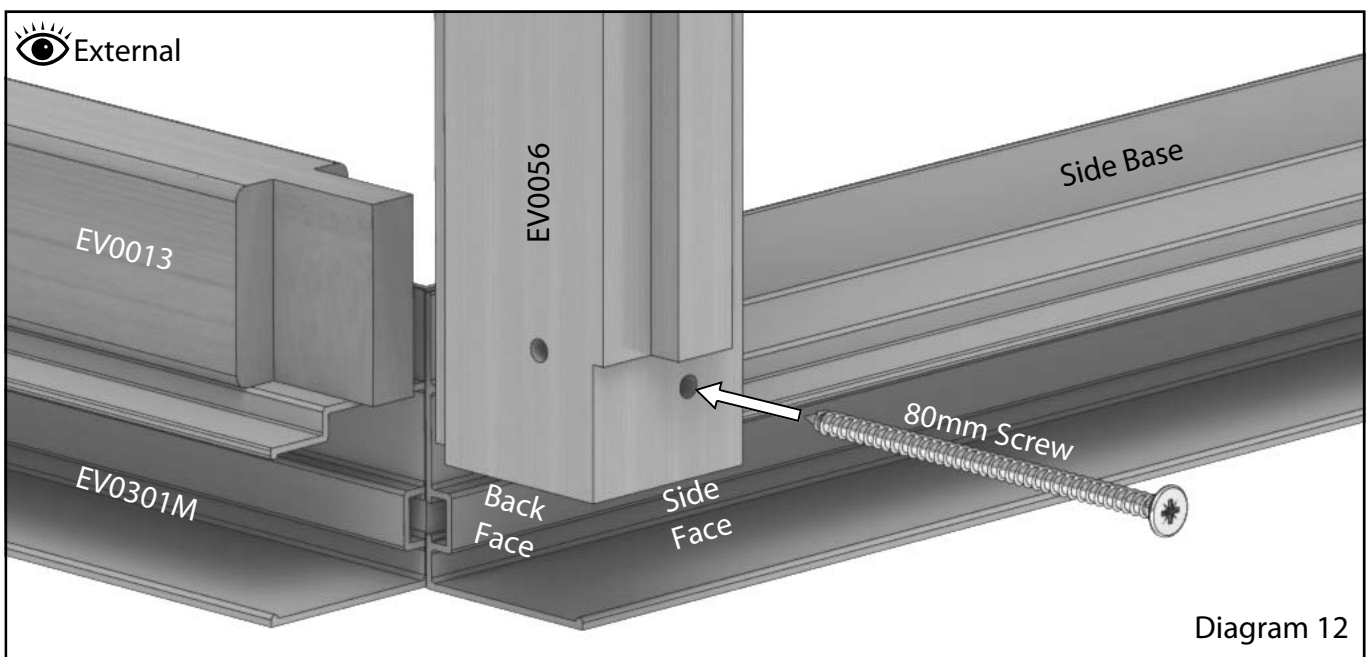

Rear Assembly

Now fit the right hand roof corner bar to the gable glazing bar (diagram 13). Be careful of this part when you have fixed it to the gable bar as it is unsupported at either end. Once you have installed the side section it will firm up.

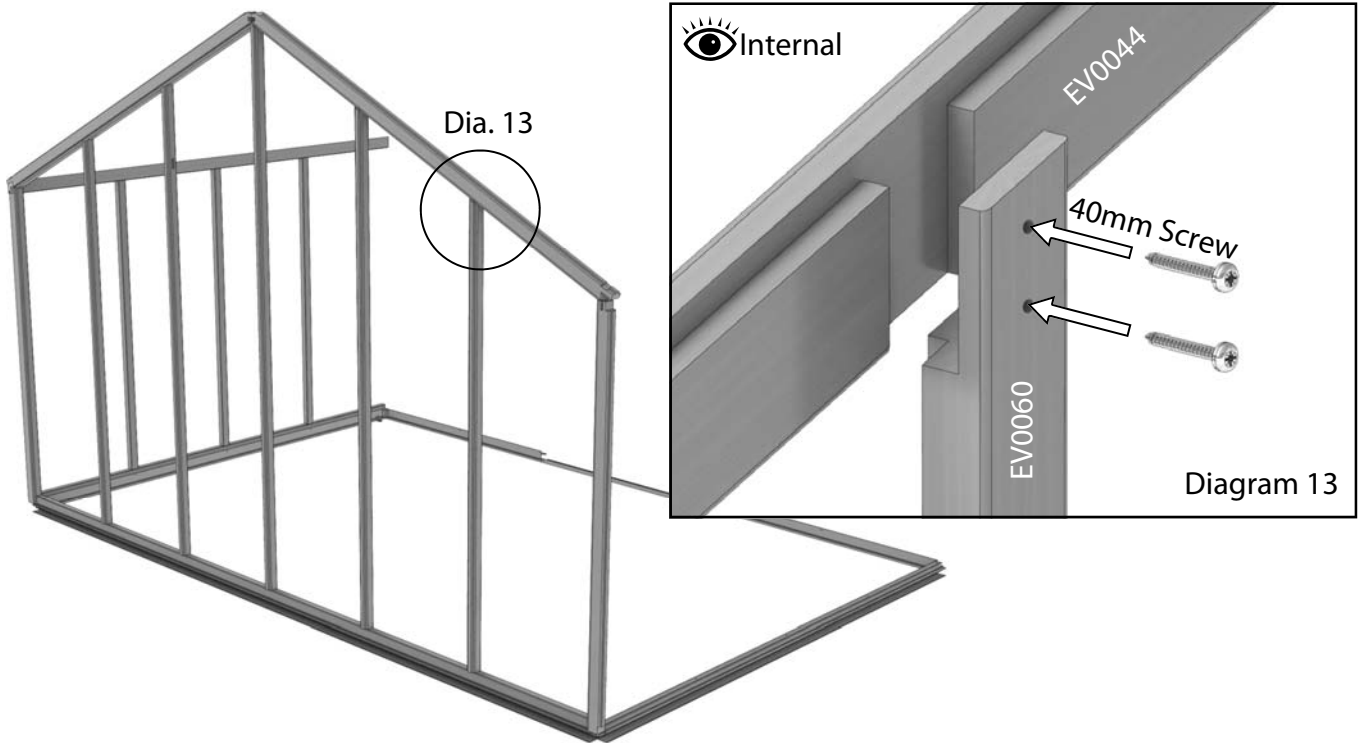

Take the second side section and place it on the base. Slot the eaves bar into the roof and side corner bar. Fix this with a 80mm screw as before in diagram 11. Fix the Side corner bar to the side cill as in diagram 6, use a 80mm screw.

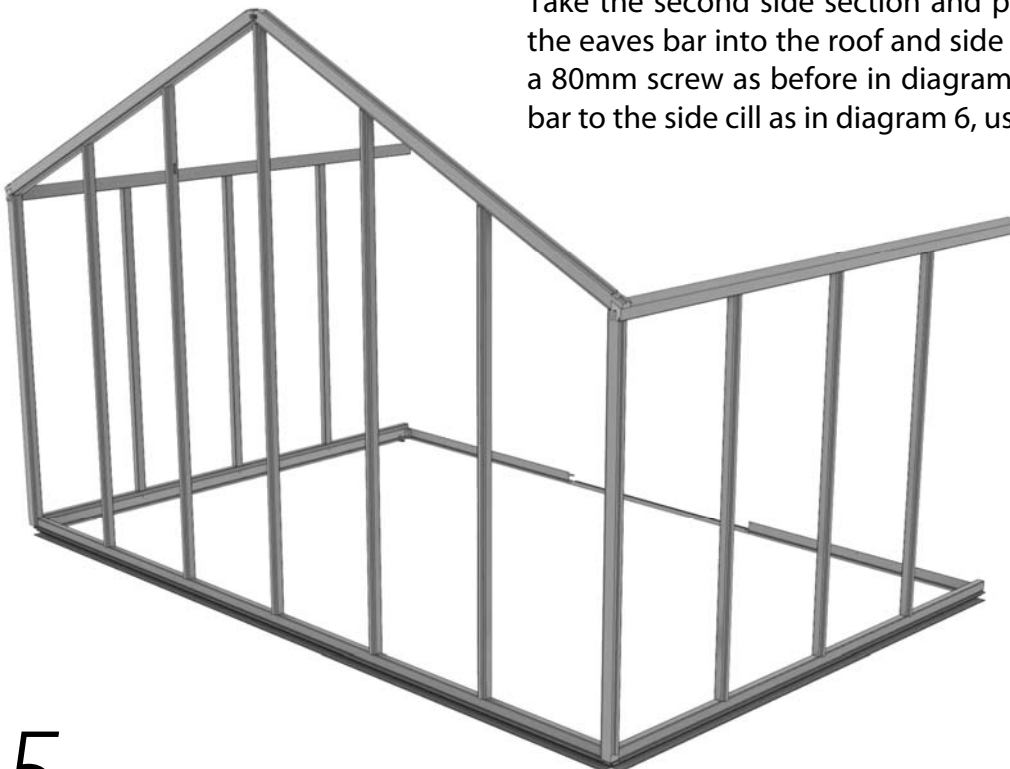

NB. If you have an extension refer to the separate manual at this stage.

Front Assembly

12ft Front			
Part Name	Part Number	Size (mm)	Qty
Front Cill	EV0008	630	2
Roof Corner R	EV0044	1446	1
Roof Corner L	EV0045	1446	1
Side Corner R	EV0056	1650	1
Side Corner L	EV0057	1650	1
Gable Bar R	EV0060	1994	1
Gable Bar L	EV0061	1994	1
Gable Bar R	EV0072	2288	
Gable Bar L	EV0073	2288	
Above Door	EV0079	344	1
Door Header	EV0109	1276	1

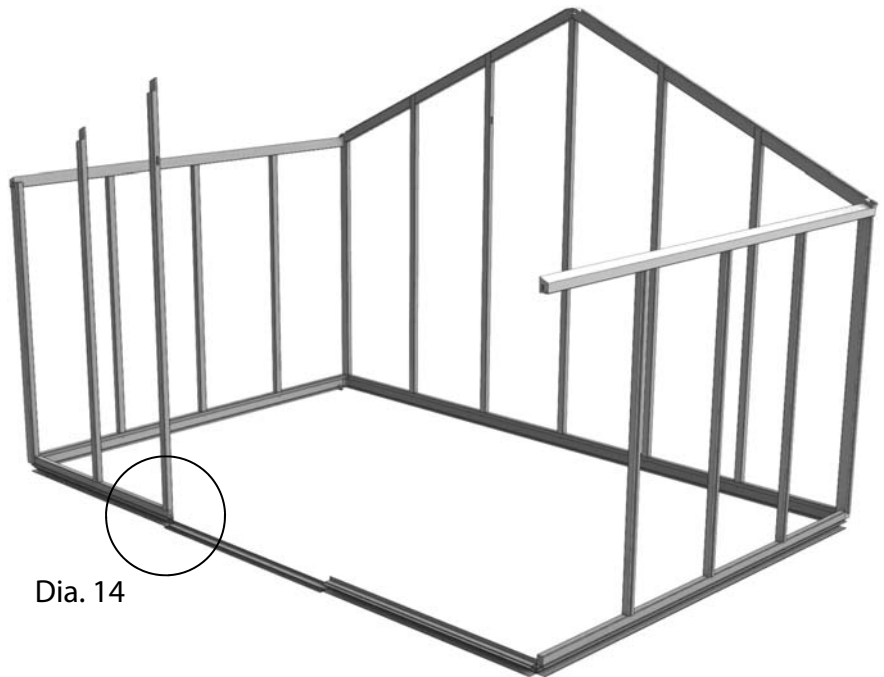

Dia. 14

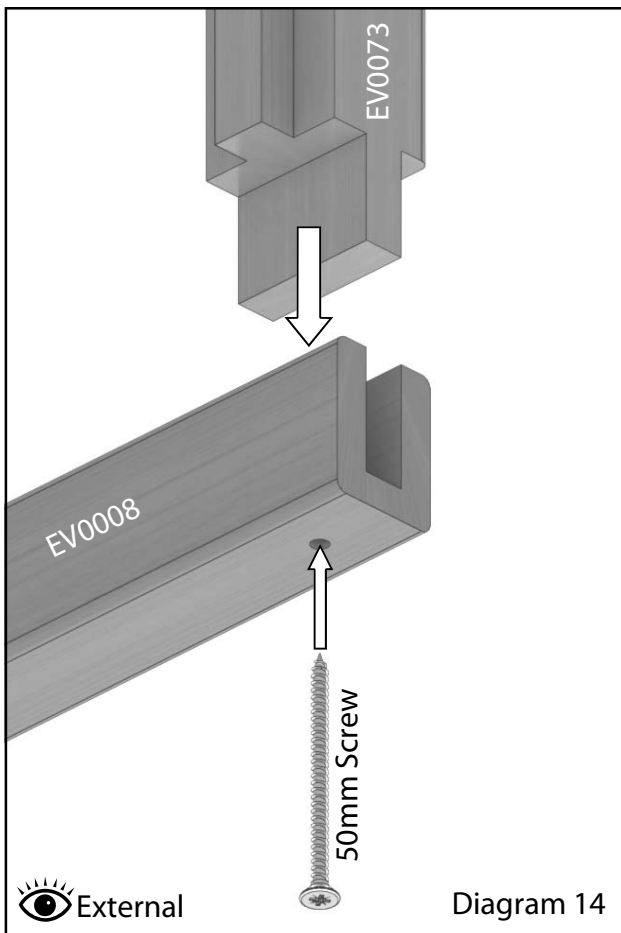

Diagram 14

With the parts flat on the ground drill the pilot holes through each mortise in the cills and as before through the lap joint on the gable bars. Also drill pilot holes through the mortise holes on the gable bars ready for the door header. Fix the front cill to the gable glazing bar using a 50mm screw.

Slot the tennon of the front cill into the side corner bar as before (diagram 9). Fix this with a 80mm screw. Also screw this to the base with 25mm screws. Keep the gable glazing bar supported while you get the next parts ready.

Front Assembly

Fix the opposite gable bar and cill in the same way. Before you install the roof corner bars you need to fix the door header in place.

Slot the door header into the mortise holes and fix with a 50mm screw through each end (diagram 16).

Make sure the gable bars are well supported while doing this.

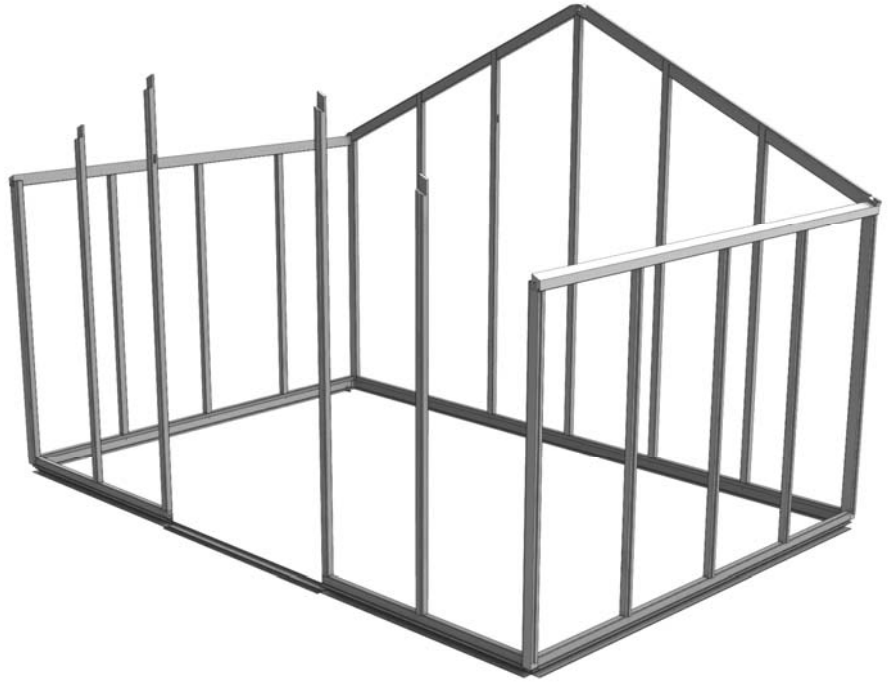

Drill through the bottom of the tennon in the door header (EV0109) then fix the glazing bar above the door with a 50mm screw using a cup washer.

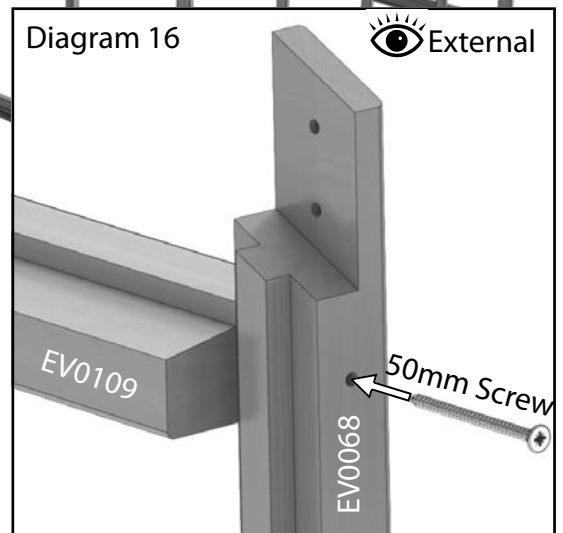
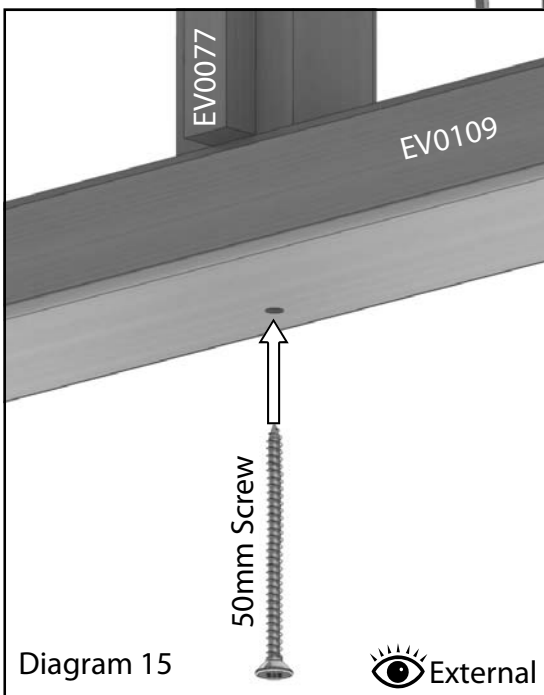
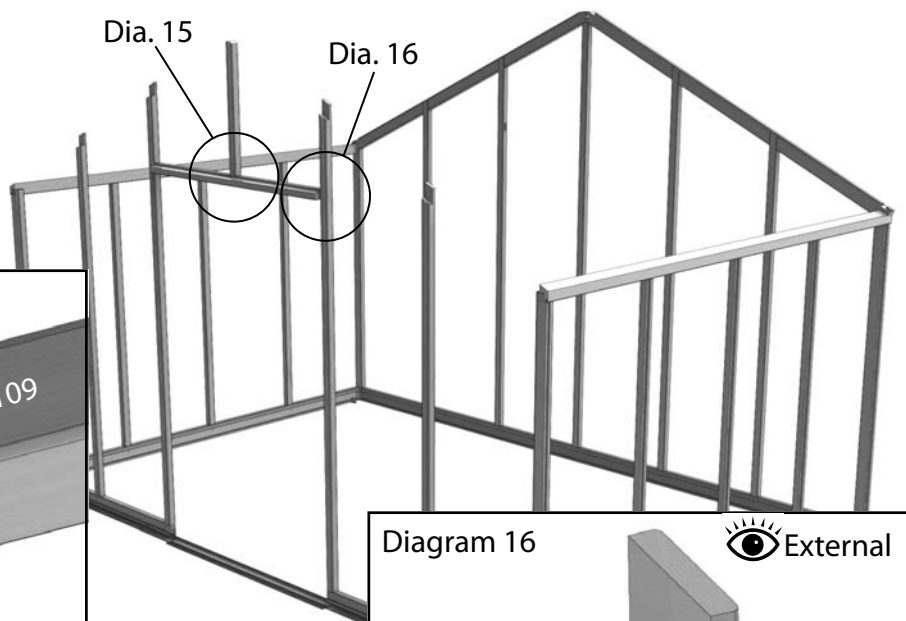

Front Assembly

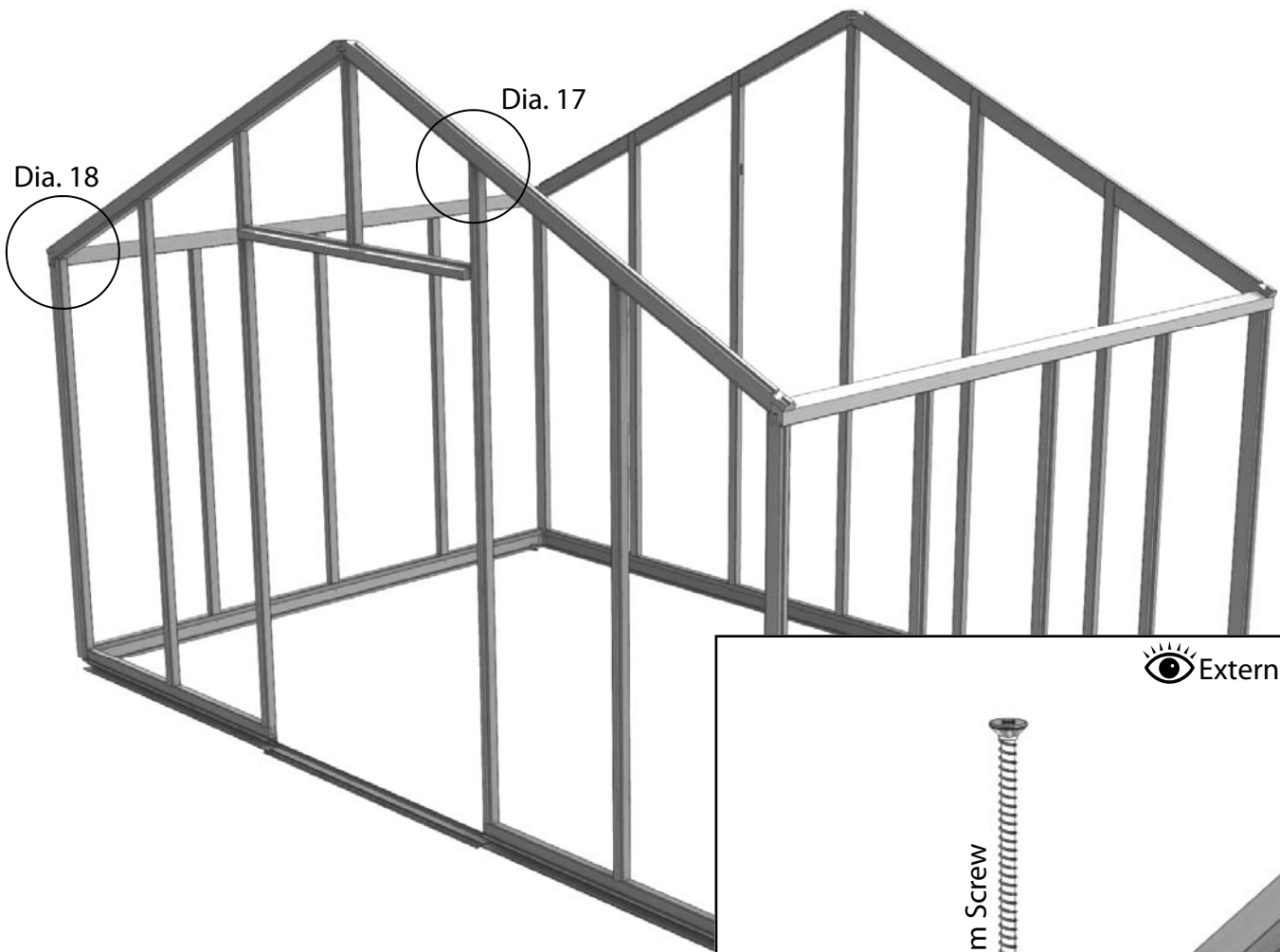

Now fit the roof corner bars to the front end. As before, fix the lap joint at the top of the gable bar first with 40mm screws (diagram 17) then secure the bottom end to the eaves bar with a 80mm screws (diagram 18).

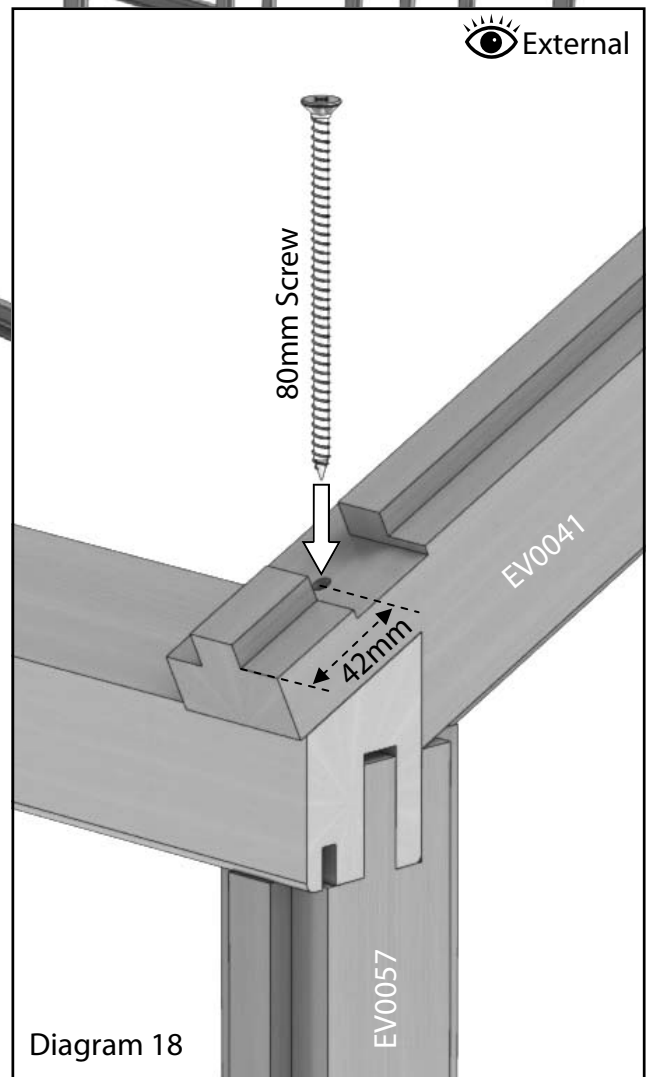
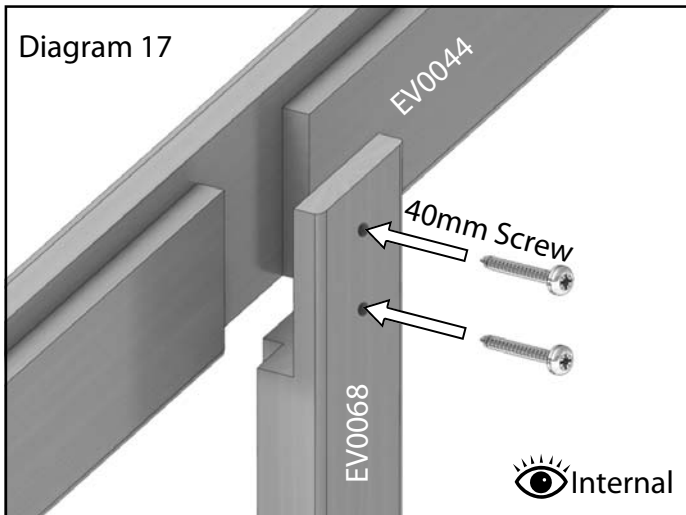

Roof Assembly

4ft				6ft				8ft <small>example</small>			
Part Name	Part Number	Size (mm)	Qty	Part Name	Part Number	Size (mm)	Qty	Part Name	Part Number	Size (mm)	Qty
Eaves Spacer	EV0024	586	4	Eaves Spacer	EV0024	586	6	Eaves Spacer	EV0024	586	8
Ridge	EV0025	1304	1	Ridge	EV0026	1934	1	Ridge	EV0027	2564	1
Glazing Bar	EV0035	2151	2	Glazing Bar	EV0035	2151	4	Glazing Bar	EV0035	2151	6

10ft				12ft			
Part Name	Part Number	Size (mm)	Qty	Part Name	Part Number	Size (mm)	Qty
Eaves Spacer	EV0024	586	10	Eaves Spacer	EV0024	586	12
Ridge	EV0028	3194	1	Ridge	EV0029	3824	1
Glazing Bar	EV0035	2151	8	Glazing Bar	EV0035	2151	10

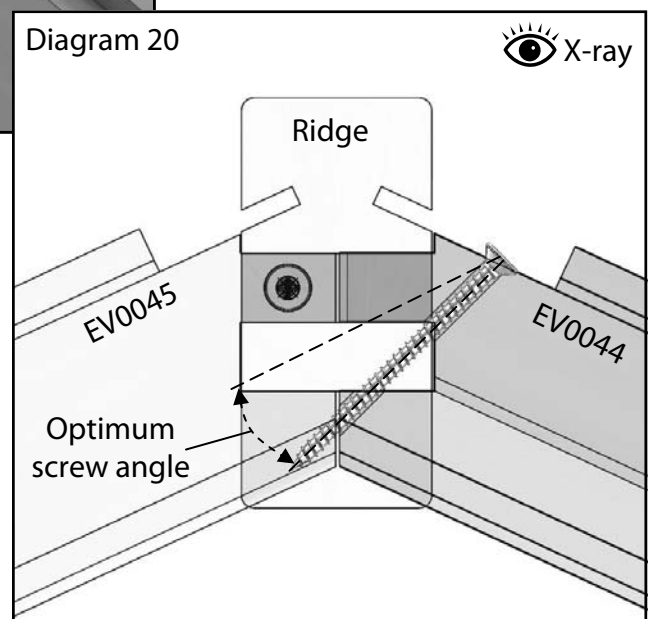
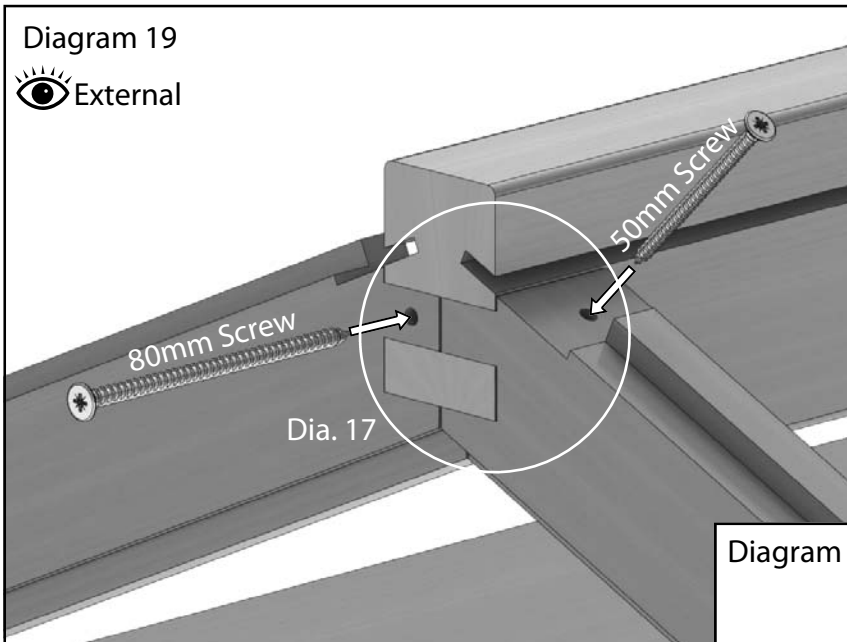

With help locate the ridge with the roof corner bars. Once into position, drill 2 pilot holes into each end as in diagram 19. Try to keep the angle something close to diagram 20, through the top face of the roof corner bars. This is to prevent the end or the screw coming through the bottom of the roof glazing bar. This angle will also give a much better and stronger fixing.

NB. If you have a Partition refer to the separate manual at this stage.

Roof Assembly

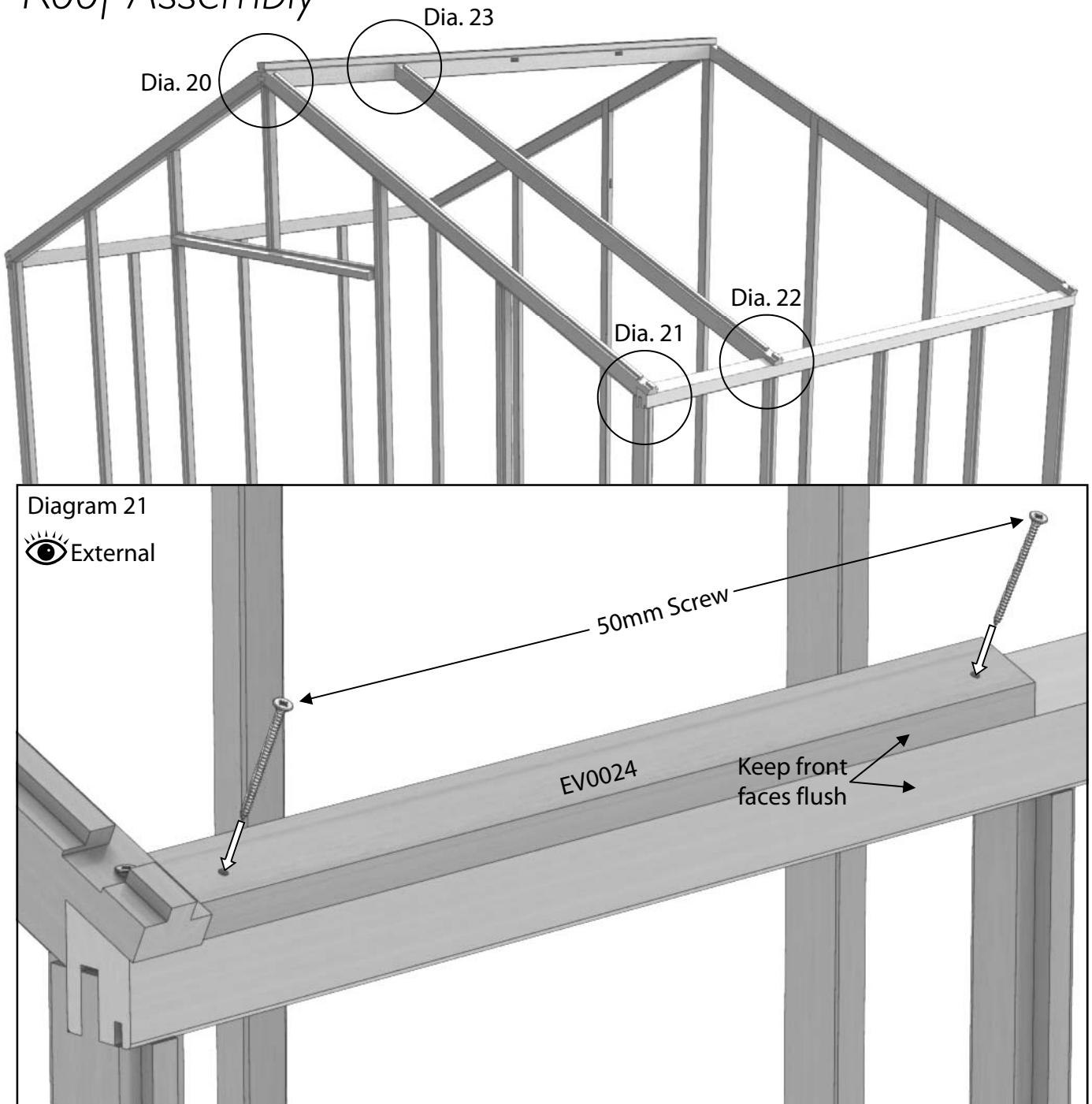

The next stage is to fix the first eaves spacer (diagram 21). This should be secured tightly up against the roof corner bar and fixed with 50mm screws. Now take a roof glazing bar, locate this with the ridge making sure it is pushed all the way into the mortise in the ridge. Then locate the bottom of the roof bar with the eaves bar making sure the inside edge sits flat against the eaves bar and drill a pilot hole vertically down. Make sure this is tight against the eaves spacer then fix this with an 80mm screw. This screw will go through into the side glazing bar securing the whole joint (diagram 22, p20).

If you have a partition remember to look at the separate instructions as you need to decide where in the building you are installing this as the roof bars are different to the standard roof bars.

Roof Assembly

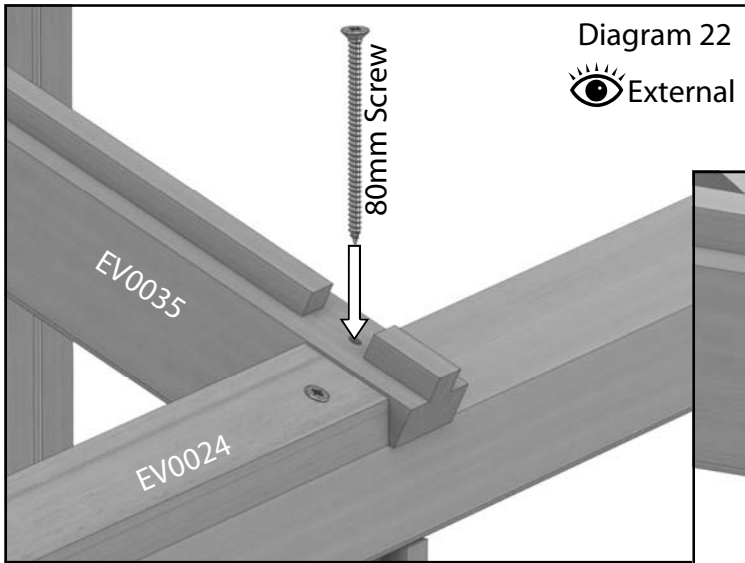

Fix the bottom of the roof glazing bars to the eaves bar with 80mm screws. Make sure the inside face of the glazing bar is flush with the eaves bar (shown below).

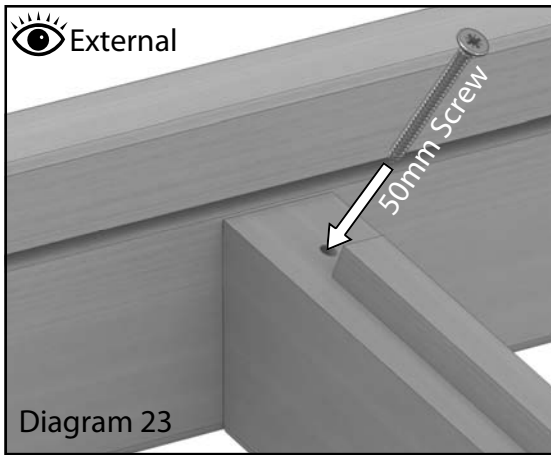
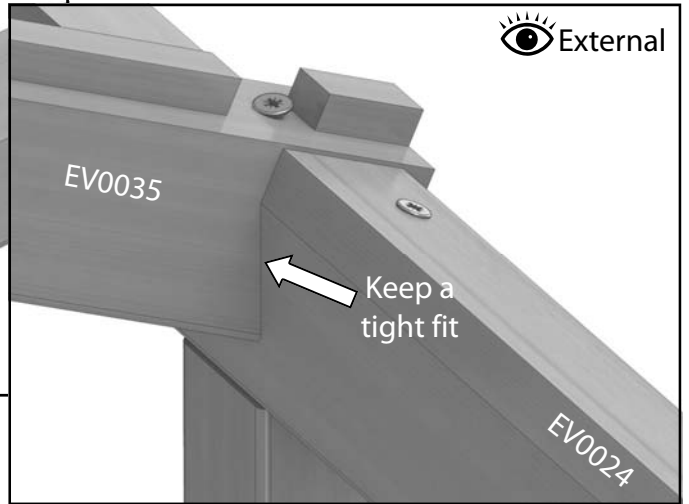

Once the bottom joint is fixed you can screw the glazing bar to the ridge (diagram 23). Do this with a 50mm screw but make sure the glazing bar is all the way into the joint. Diagram 24 shows an X-ray view of the end of the ridge. This shows the best angle for the screw. Again you want to be careful the end of the screw doesn't come through at any point. (Don't worry too much about the screw ends crossing, if this happens as you are putting the screw in it will simply push past the other screw).

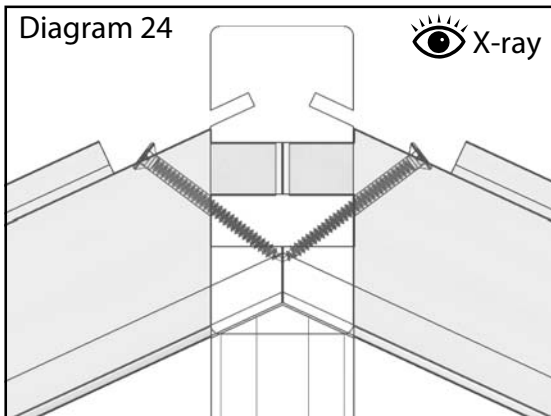

Repeat this all the way round the roof until the frame is complete.

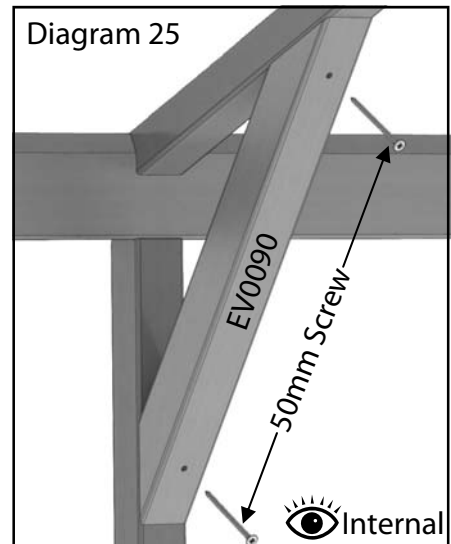

Before you start fitting the bracings check the distances between the two sides along the length of the eaves bar. On larger buildings it may be necessary to tie the two sides together before attaching the bracing to reduce any sag.

Roof Assembly

Now fit the gallows braces to the middle glazing bars at each end of the greenhouse, diagram 26. Firstly attach the small bracket with 25mm screws. Then use 50mm screws to fix them in place. Make sure the rebate of the glazing bar is in line with the glass groove in the roof corner bars (EV0040 and EV0041).

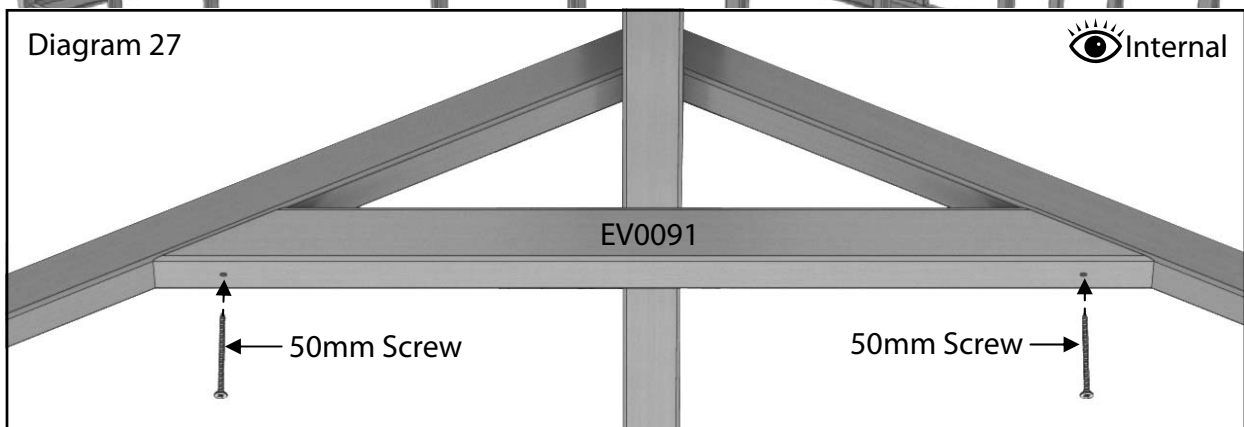
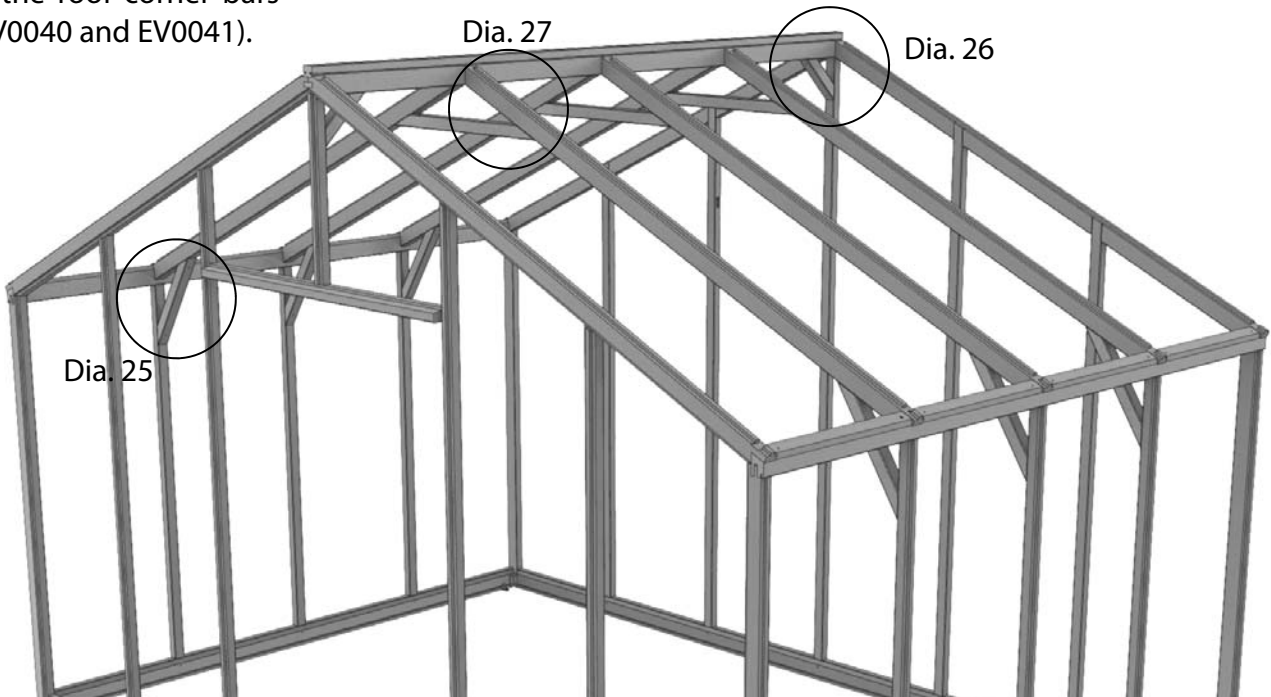
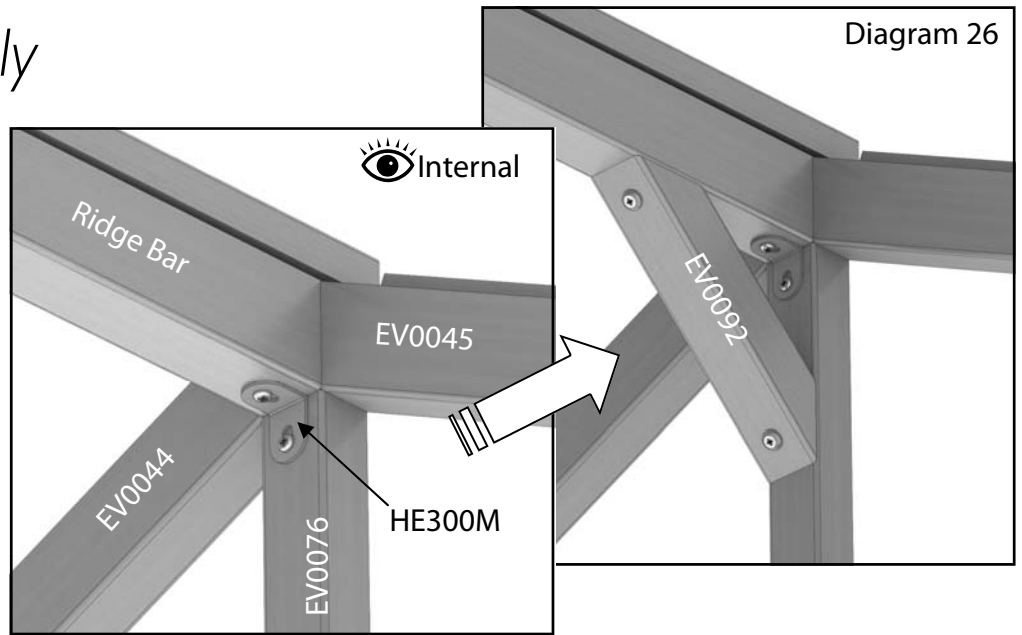

Fix the eaves braces (diagram 25) and the ridge braces (diagram 27) evenly along the building with 50mm screws.

Once the braces are attached you can remove any temporary ties.

Louvre Assembly

To start building your louvre you first need to assemble the sides. Connect the two side section with the two inserts as shown here.

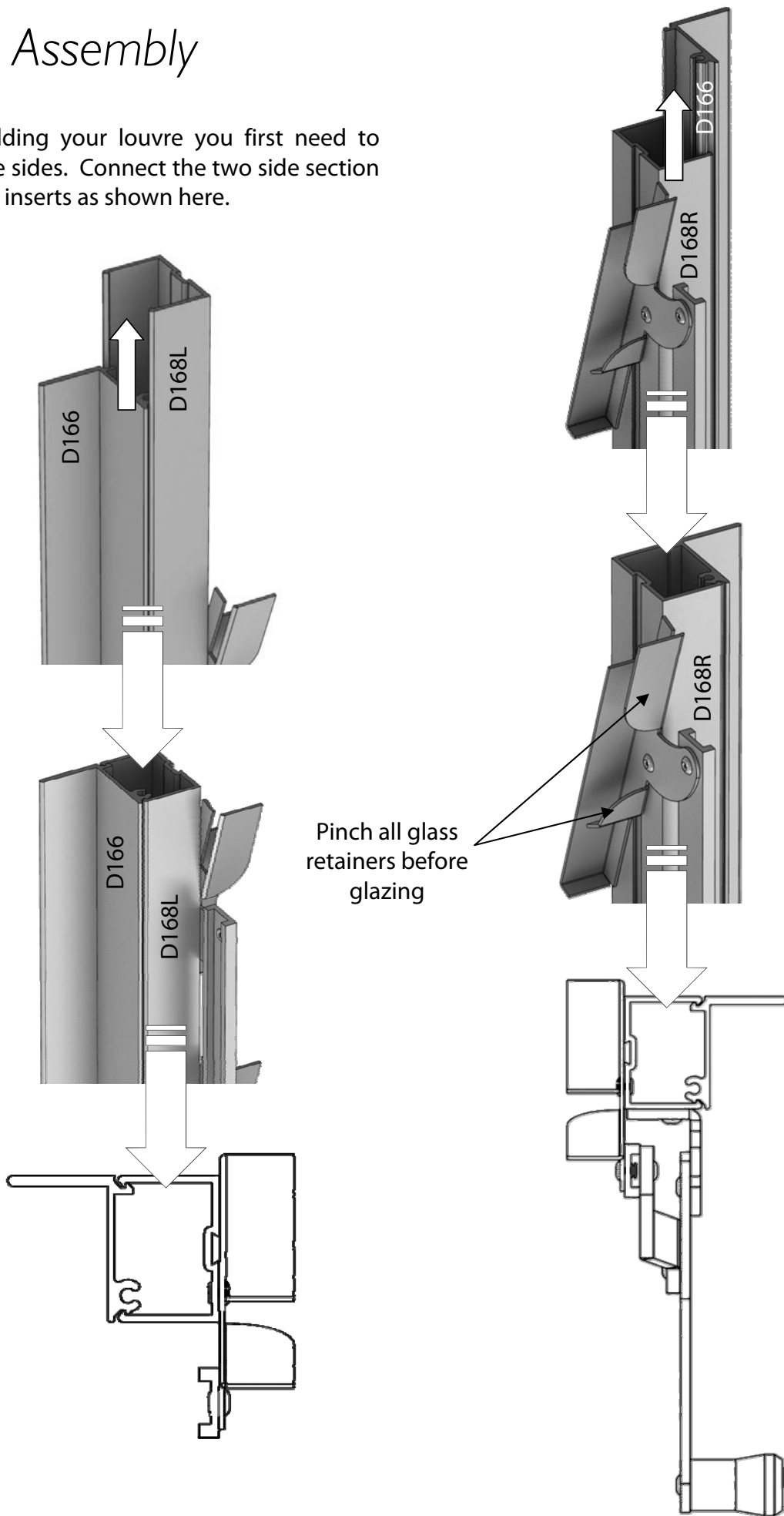

Louvre Assembly

Louvre			
Part Name	Part Number	Size (mm)	Qty
Louvre Top/Bottom	D165	612	2
Louvre Side Insert	D166	552	2
Louvre Side	D168L	552	1
Louvre Side (handle)	D168R	552	1
Assembly Screw	FS6013	12	4
Louvre Glass	D729TG	100 x 525	6

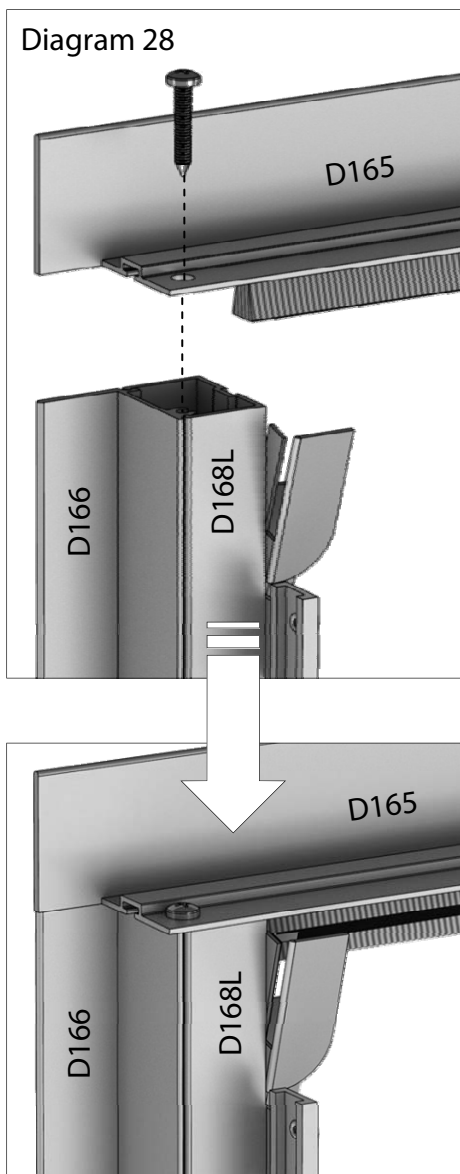
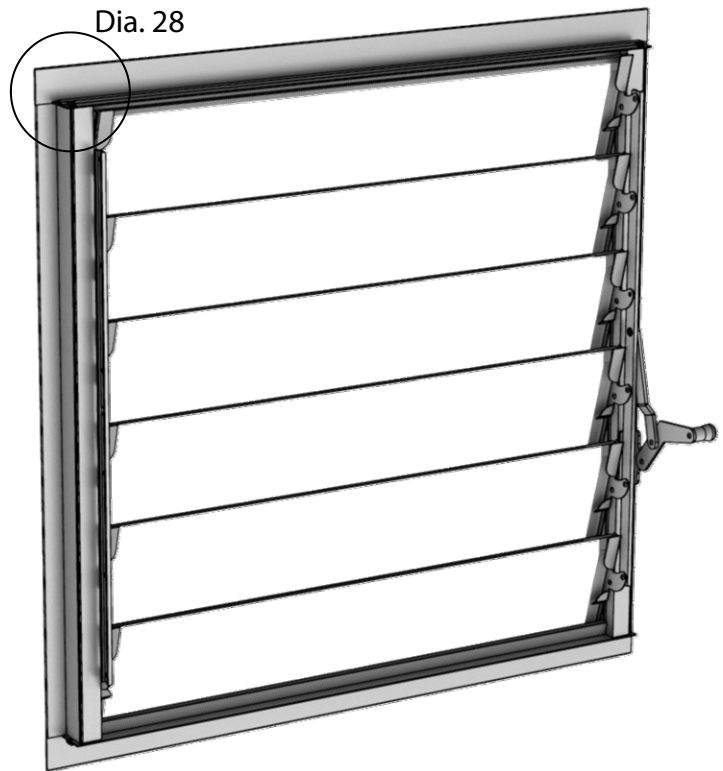

Now you have assembled the side trim the rubber seal flush with the ends. Attach the top and bottom of the louvre with the 12mm assembly screws. In each end. This locates with a screw channel in the side sections. Makes sure you pinch the glass retainers as this helps secure the glass when in place. You will find your louvre glass in the box with the louvre. You can install this now but it is easier to do so when the louvre is in the frame of the greenhouse.

Glazing

There are 2 types of capping available on this range of greenhouses. The standard cedar capping or the upgrade aluminium capping.

If you have the Aluminium capping you need to slide the glazing rubber into channels on the back of the capping. Use a Stanley knife or scissors to cut to length, it is best to use a complete length per side.



If you have the cedar capping you need to pre load each strip with the 25mm screws. Also before you install each pane you need to run a thin bead of silicon up each glazing bar (no greater than 5mm is needed).

All of the capping is pre-cut to length, so sort through it placing the capping around the building close to where you can reach it. Start by glazing the first side section. Make sure you have the first piece of capping to hand.

Glass Size	106	108	1010	1012
A	4	4	4	4
B	4	4	4	4
C	2	2	2	2
D	2	2	2	2
610x1635	14	16	18	20
610x1520	6	8	10	12
610x868	2	2	2	2
610x153	2	2	2	2
525x100	12	12	12	12
610x610	1	2	3	4
610x642	5	6	8	10
558x997	2	2	2	2

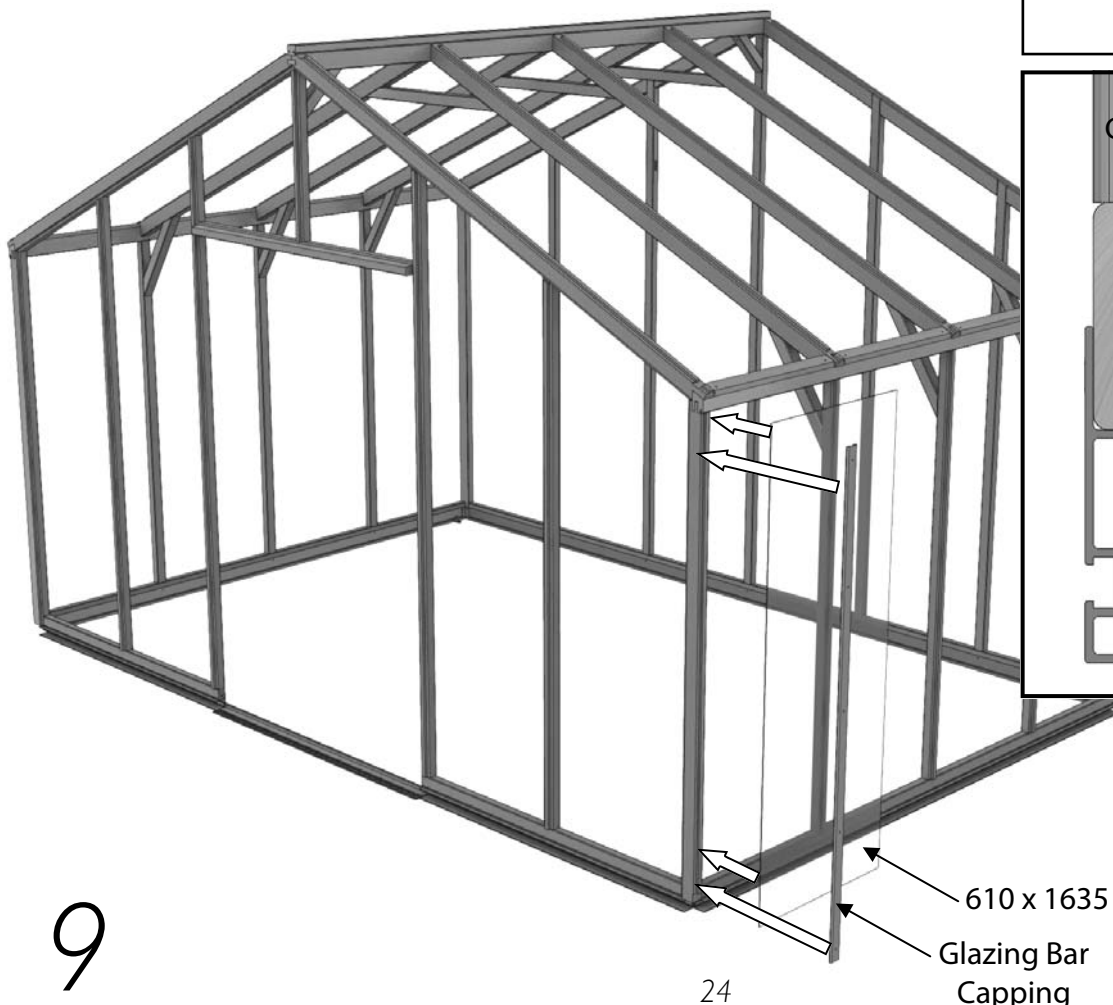
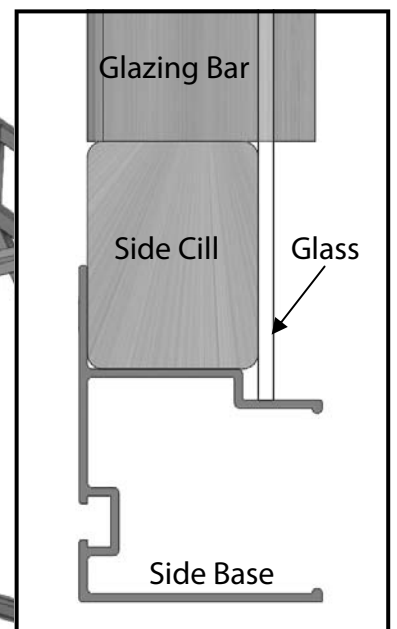
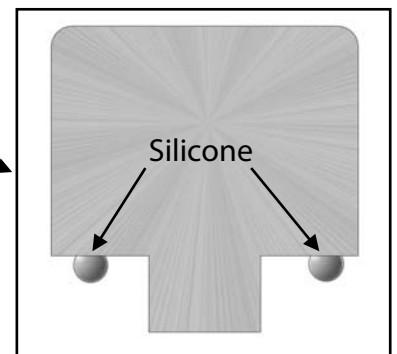

Slide the glass into the rebate of the eaves bar and rest it on the aluminium base as above.

Glazing

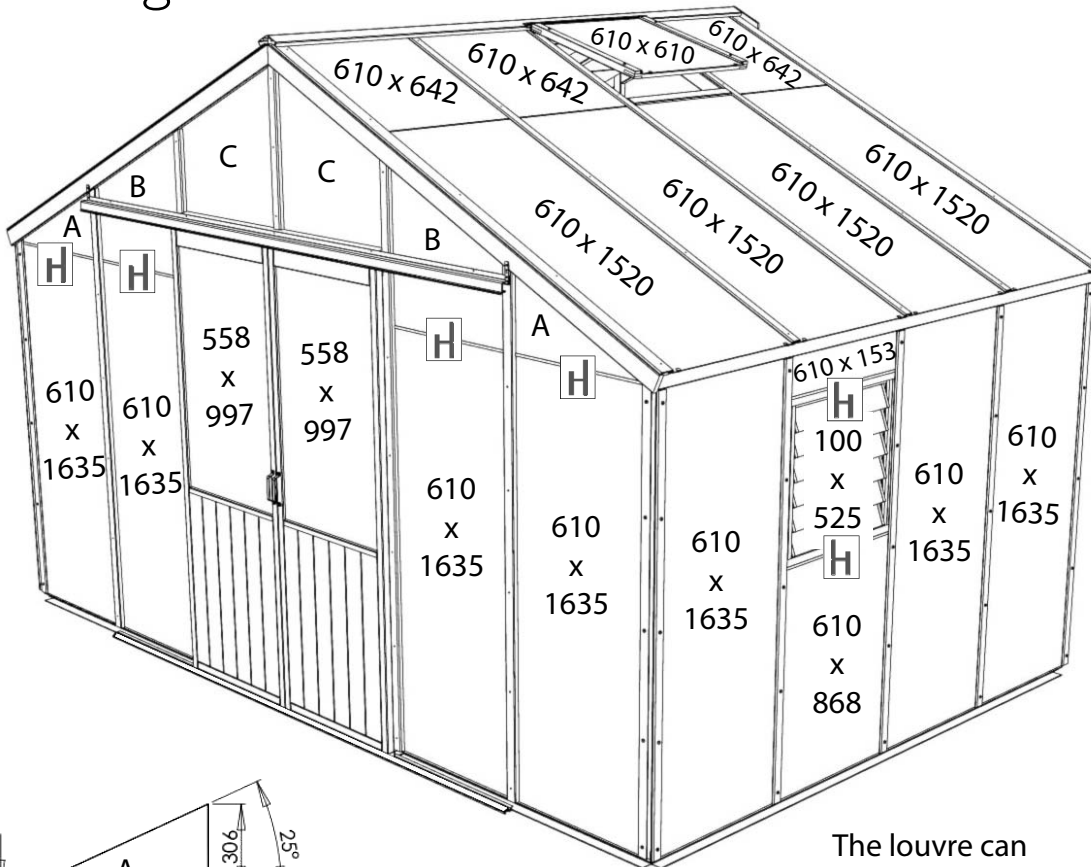

Keep the short flange pointing upwards on the outside.

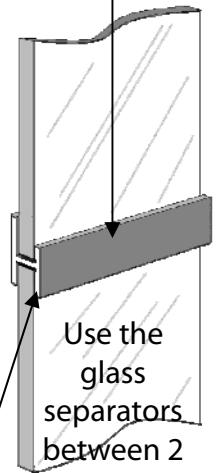

Use the glass separators between 2 panes of glass and above and below the louvre

The louvre can replace any of the 610x1635 panes

Note: All channels in the aluminium capping should have rubber inserted, even if it is going onto the timber.

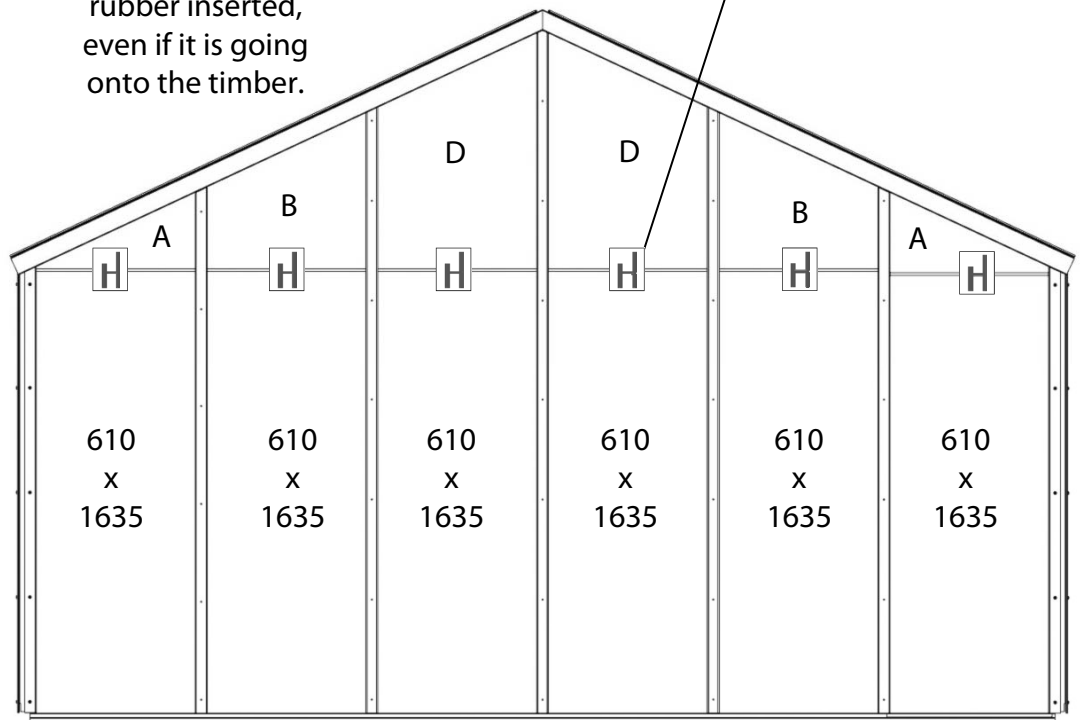
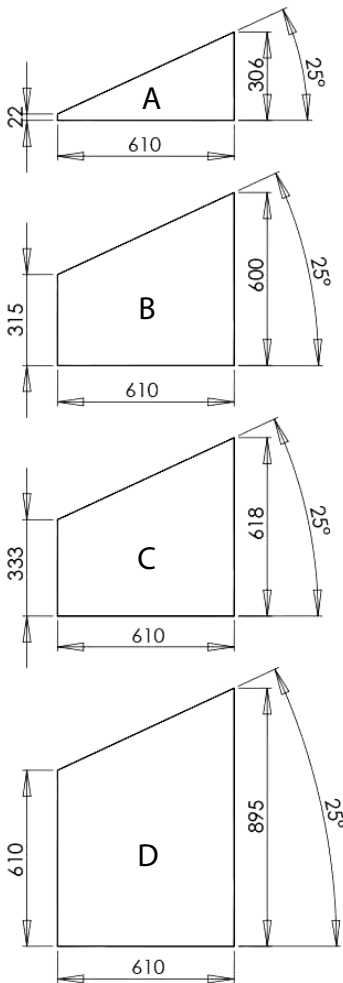

Rear End

Glazing

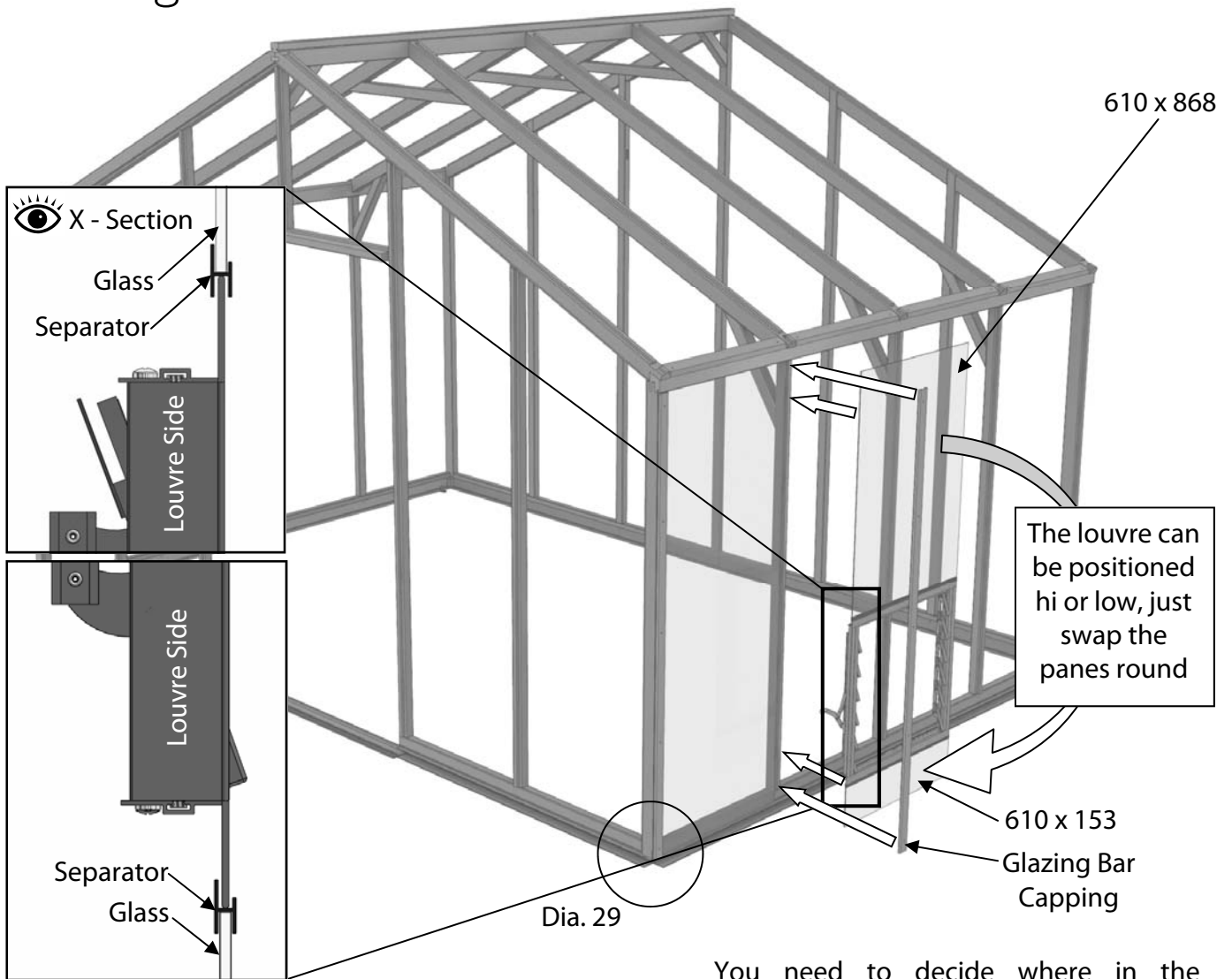

You need to decide where in the building you are having your louvre(s) Above is an example of how it might be fitted. The louvre can replace any of the 610 x 1635 panes, but make sure the handle operates and that there is no interference with the glass in the location that you choose. Make sure you fit it the right way up (the handle is always on the right standing on the inside). Once in position fix the next piece of capping. This has now fully secured the previous pane and partially secured the current one.

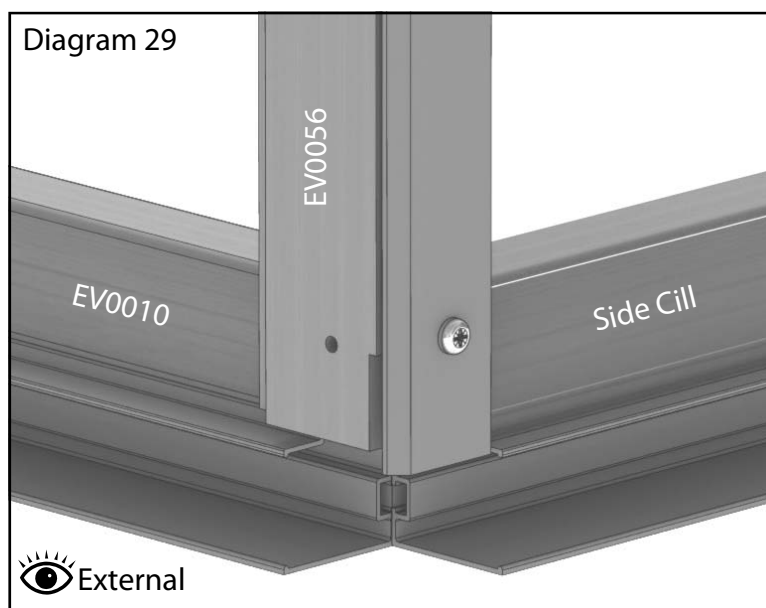

Keep working round the building in the same direction, fitting louvres when needed. If you are right handed it is easiest to work left to right and vice versa!

Glazing

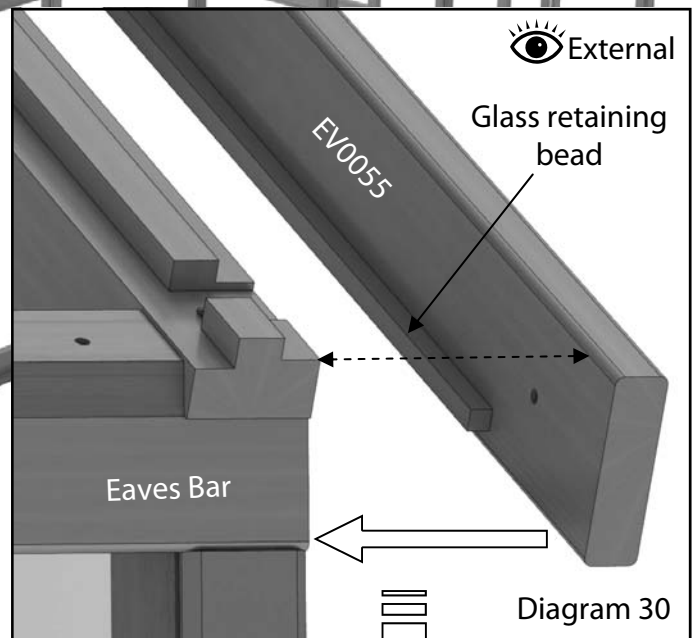
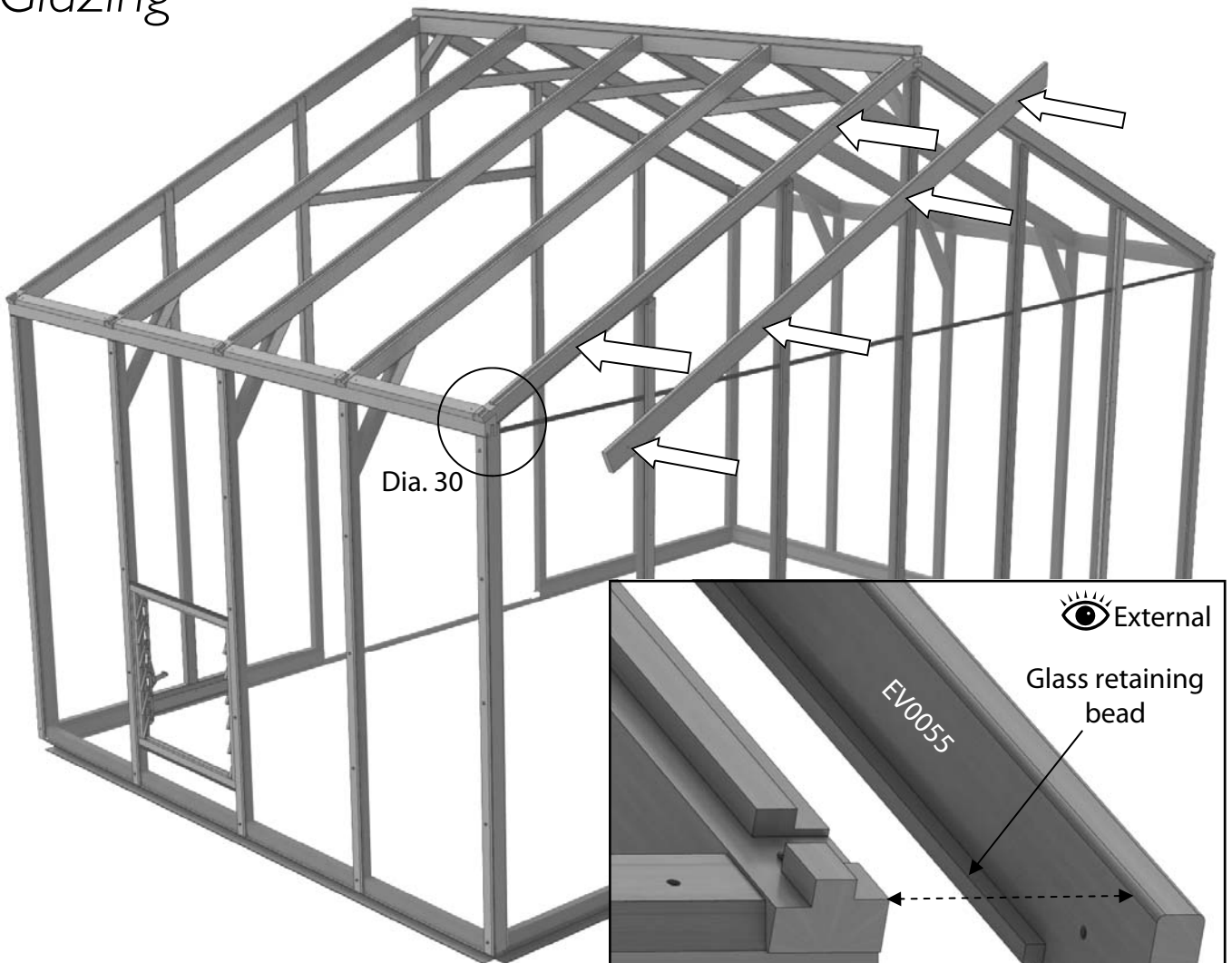

Install the rear glass in the same method as the side glass, the only difference is you have to stack the shaped panes on top using the glass separators. Make sure you have all the glass to hand when you are glazing this section. It is also a good idea to have an extra pair of hands to hold glass in place while you get the next section of glass in place. Always keep the glazing capping flush to the aluminium base level with the bottom of the glass.

Once the vertical capping is on you can fit the roof corner cloaking strips. These are handed as they have glazing beads already attached to them to secure the shaped panes along the top edge, so make sure you have the correct one (see page 28 for a guide).

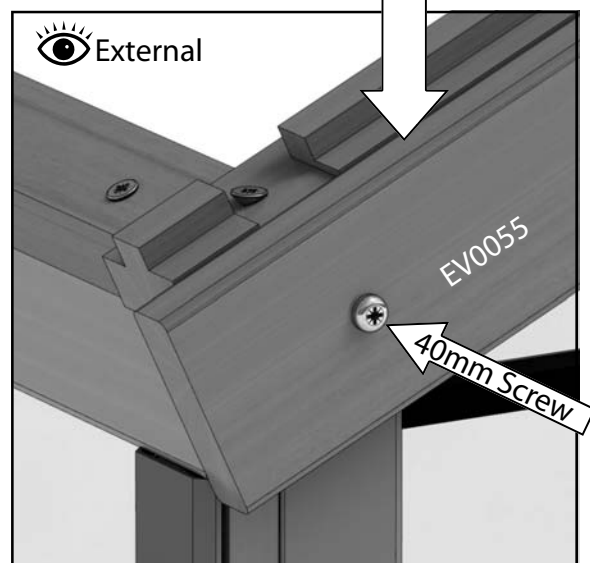

Glazing

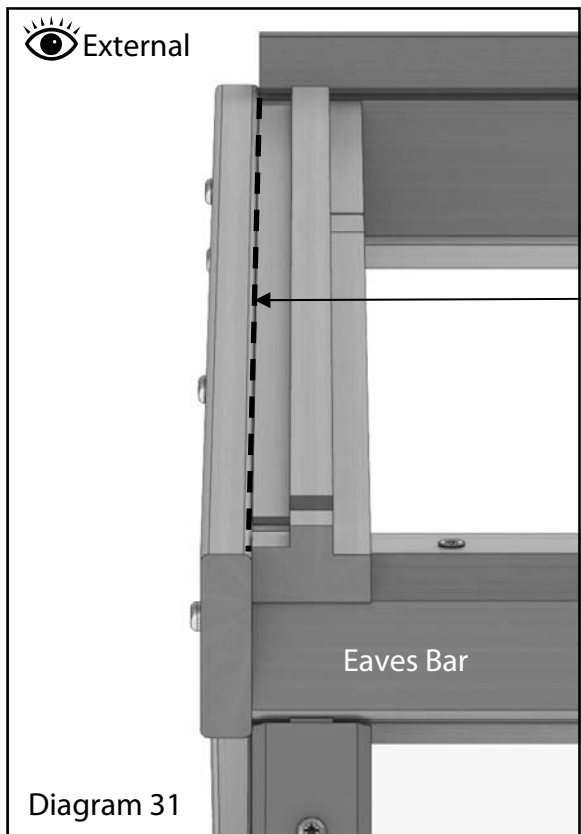
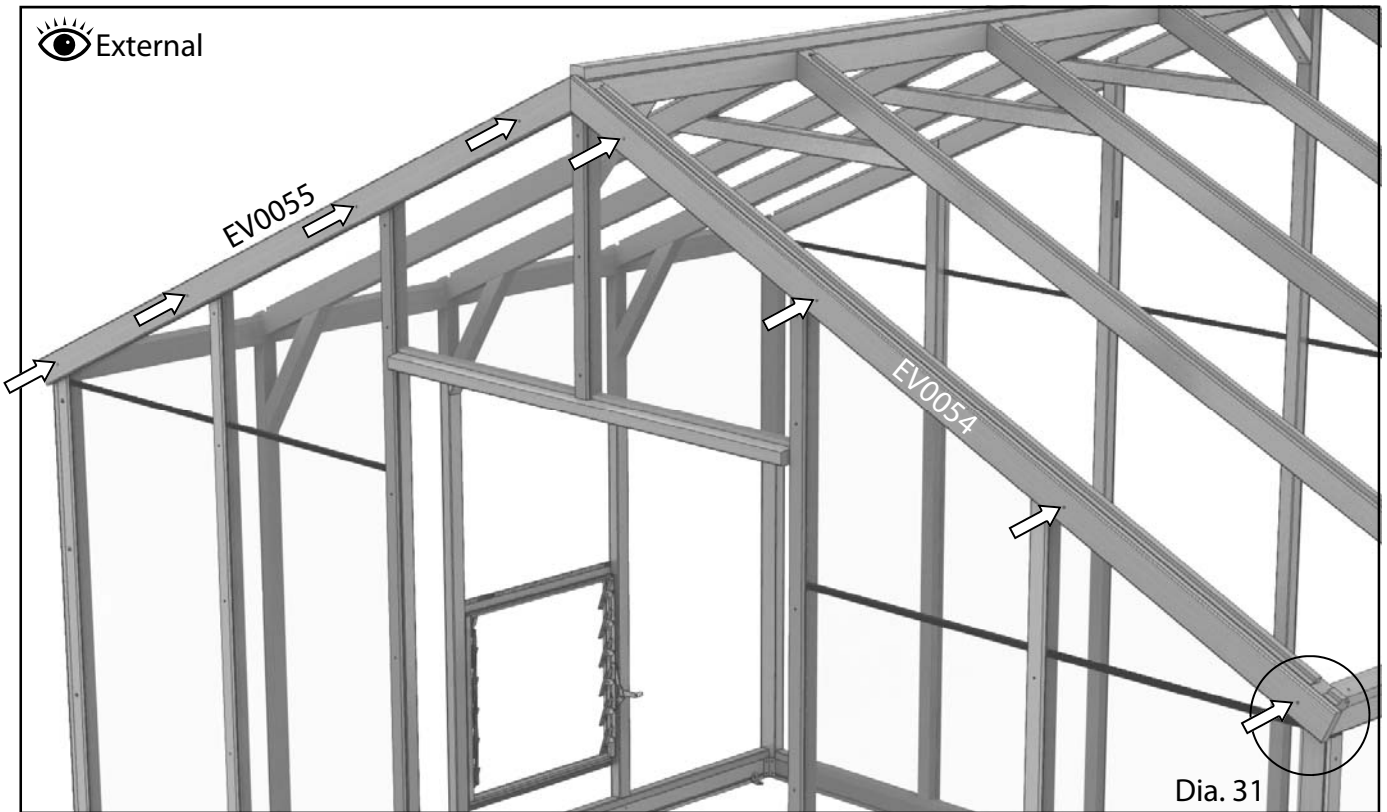

Glaze the remaining side sections as before. When you come to the front end glaze this as you did the rear end.

Once all the roof corner cloaking strips have been installed run a bead of silicone all the way down the joint between itself and the roof corner bars (diagram 31).

Next you need to decide on the location of your roof vents. These can NOT be fitted side by side. Once you have decided this start by installing the glass that goes underneath the vent. Use 2 of the glass stops per pane (it is best to locate these over the screw heads in the eaves spacers) see diagram 30.

Glazing

There are 2 grooves in the slam rail, the one nearest the edge should be used for the aluminium capping and the one nearer the middle for the cedar capping.

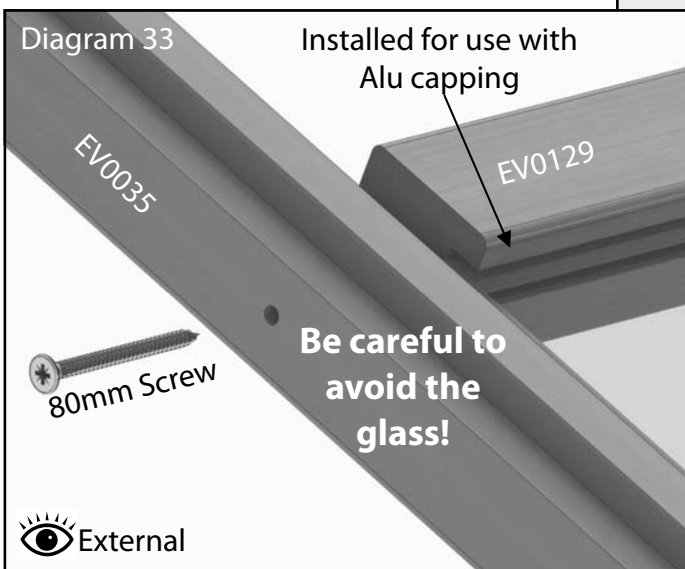
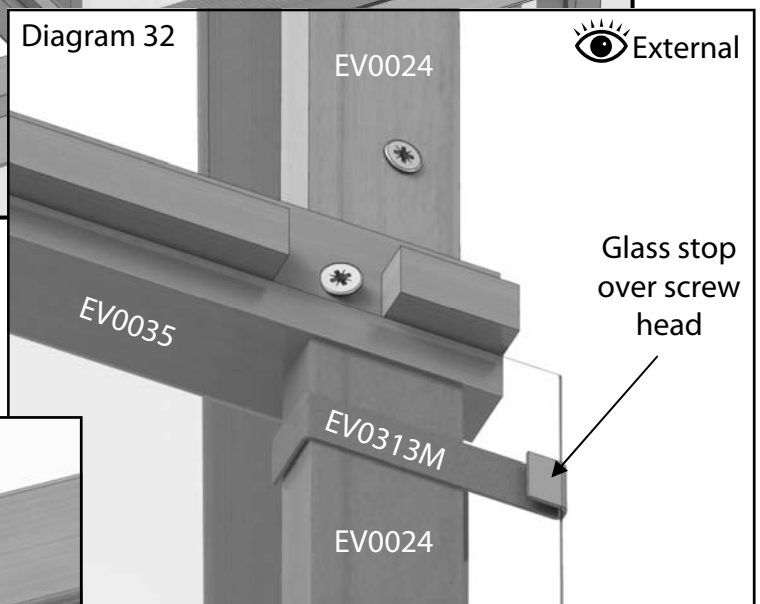
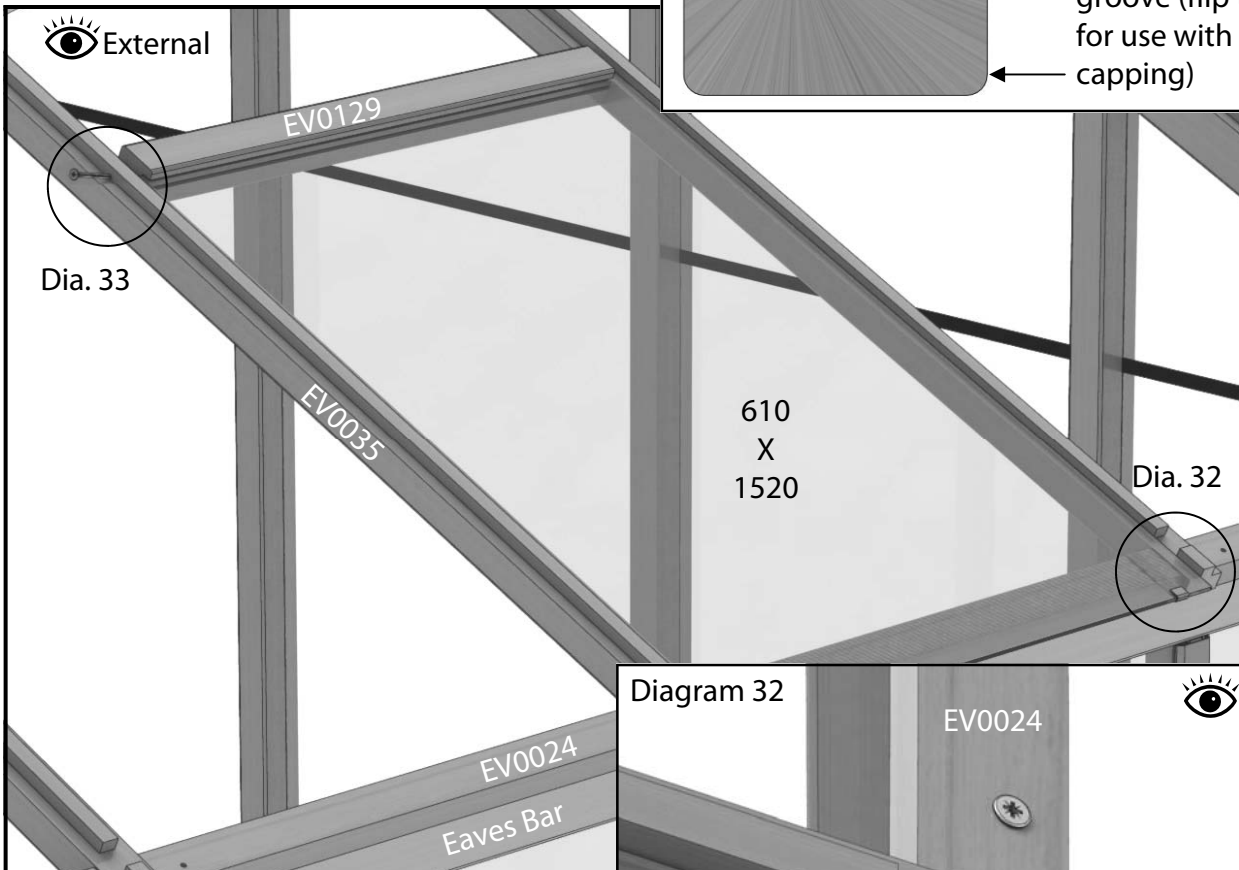
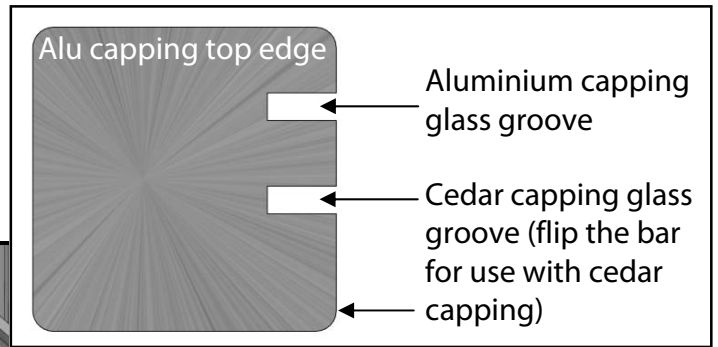

Then position the slam rail (EV0129) on top of this pane of glass. This should be fixed with a 80mm screw through the side of the glazing bar (remember to pilot drill first), sink the head slightly into the timber for a neat finish.

Glazing

Before glazing the roof install your ridge cover cap. Follow one of the options below.

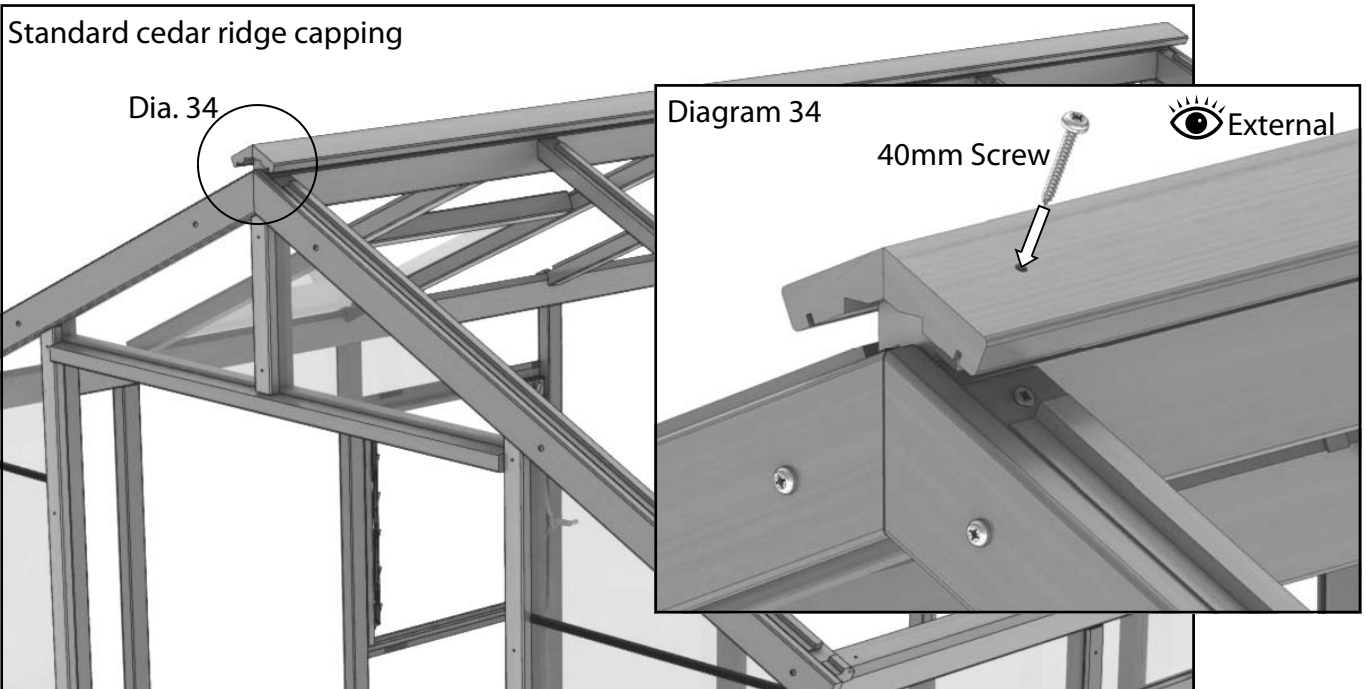

For the cedar cap fix one side in place then run a bead of silicone the full length of the cap where the next piece will join. Fix the second piece tightly against the first. Use 40mm screws for this cap.

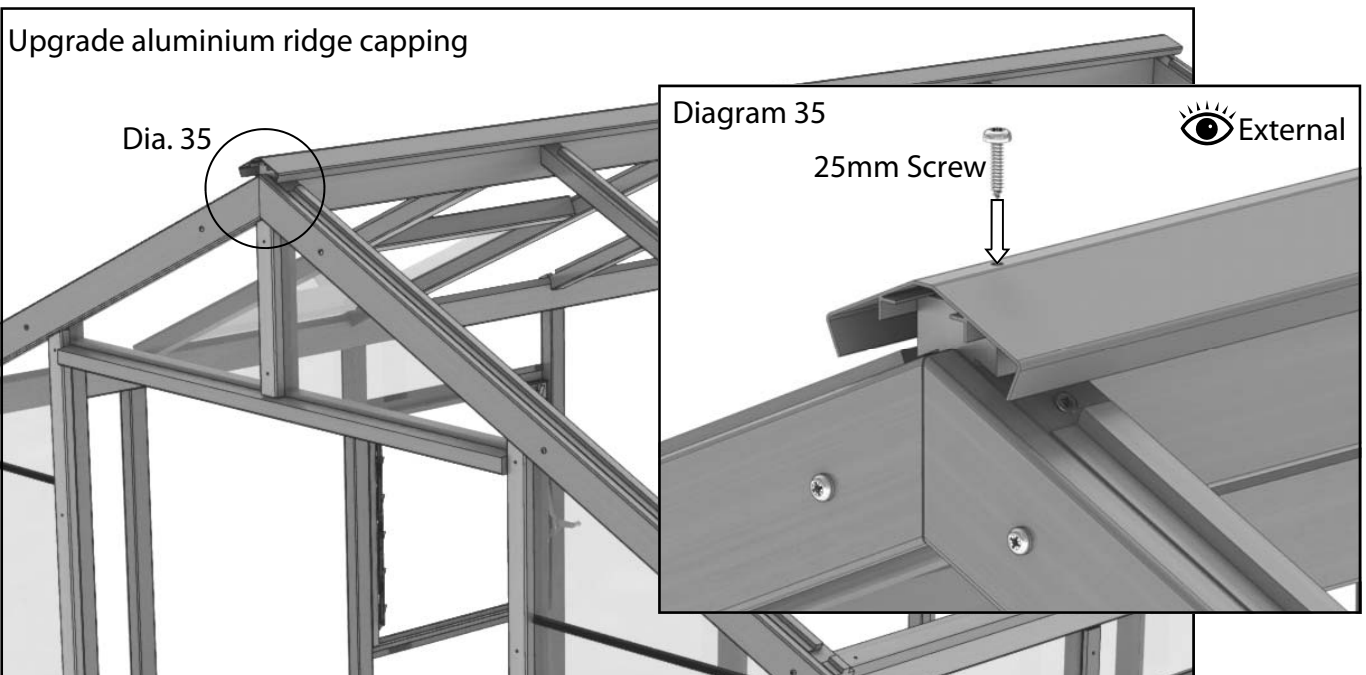

With the aluminium cap simply place this on the ridge and fix with 25mm screws.

Glazing

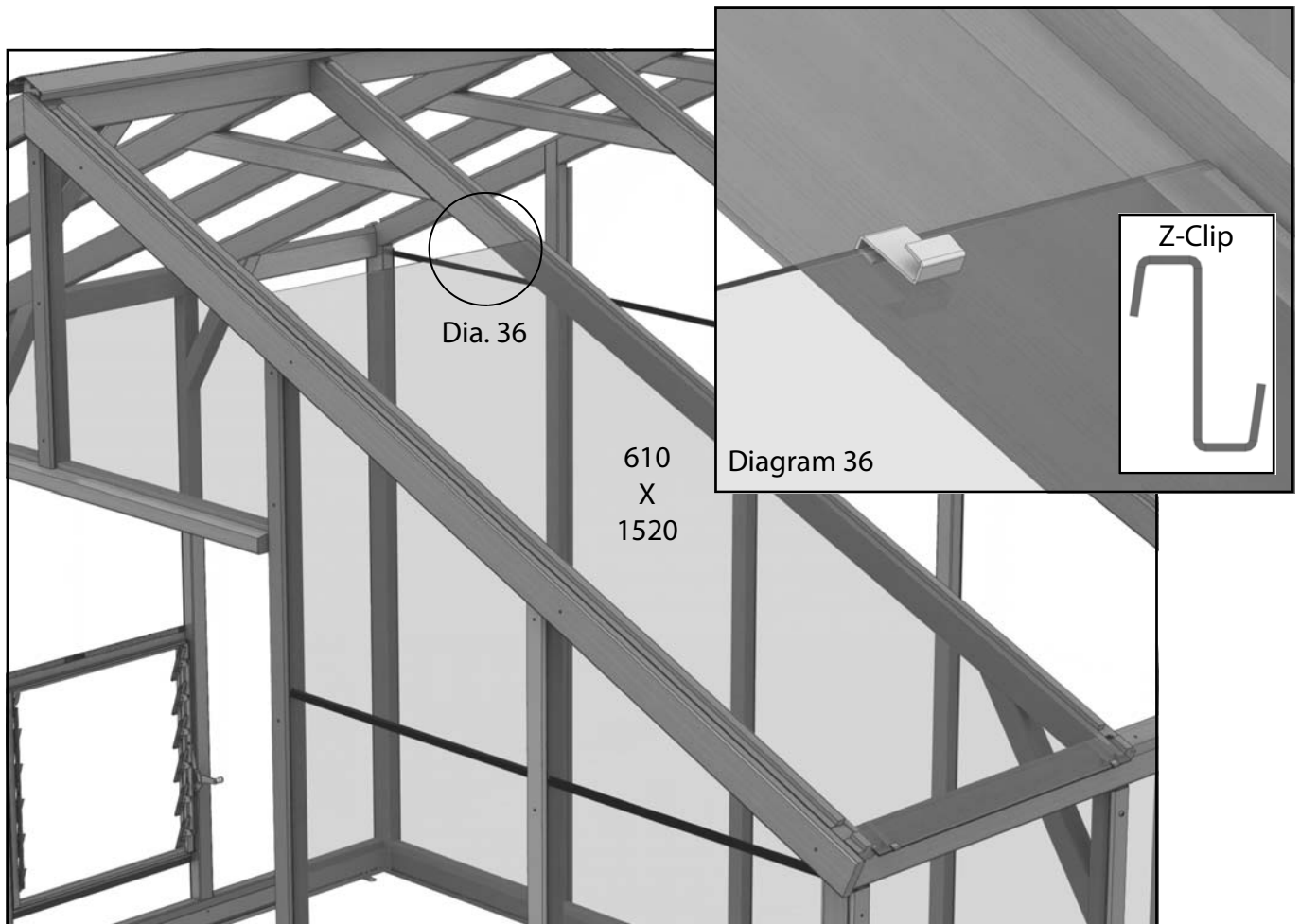

Now complete the glazing by fitting the roof panes. Slot 2 of the glass stops (diagram 32) on the 610 x 1520 pane and lower the pane down onto the eaves bar. This will now support itself while you fix 610 x 642 pane above. Fit the Z-shaped clips on the top of the larger pane (diagram 36) and slot the smaller pane into the ridge and lower it down onto the Z-clips.

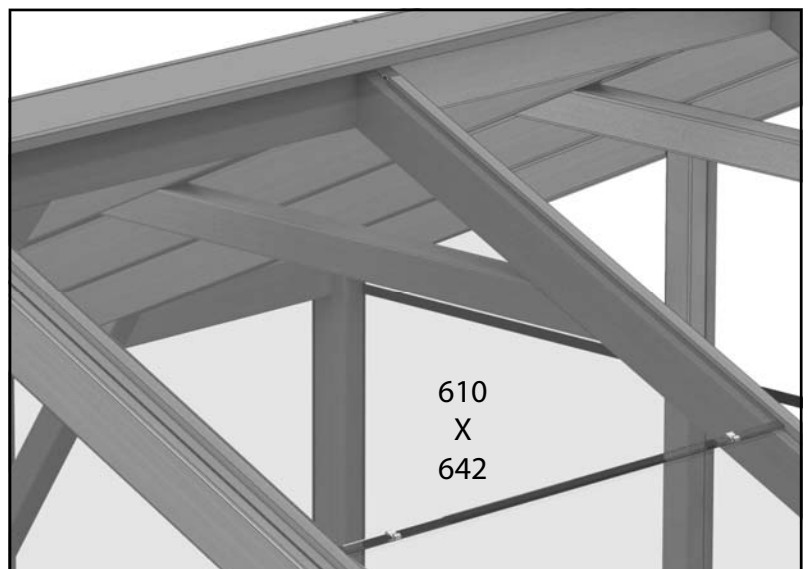

Glazing

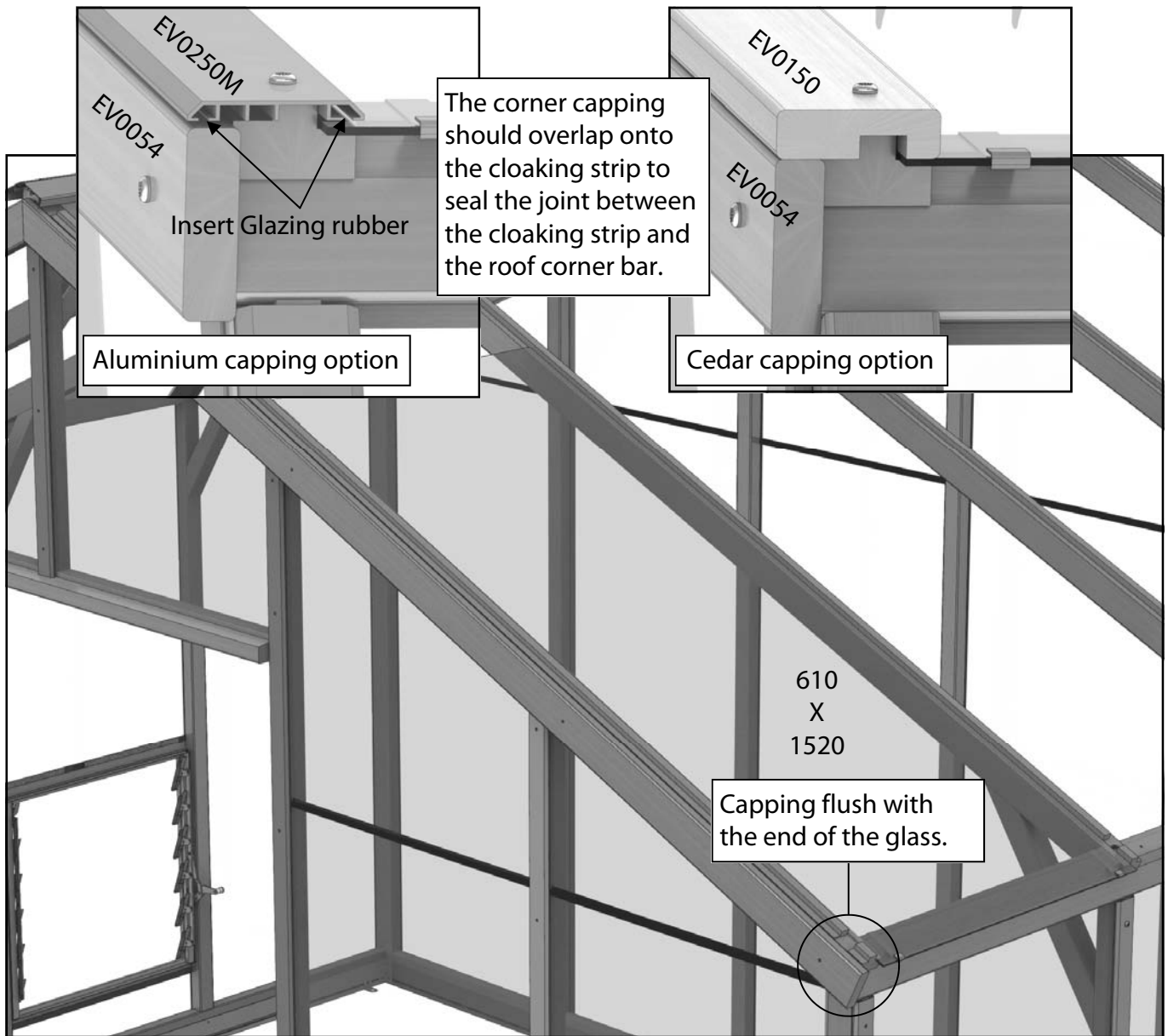

The capping for the roof corners is wider than normal to cover the join of the cover strip to the roof corner glazing bar. The capping should also be fitted flush with the bottom edge of the glass at the eaves.

Note: Use the 19mm countersunk screws where a vent is to be used so the head of the screw doesn't prevent the vent from closing properly.

If you haven't already done so you can now install the louvre glass in the sides.

Door Installation

Before installing the door you need to fit the running gear. Start by assembling the door wheels onto the door top bracket, diagram 37. Once assembled fit the bracket to the top of the door using 25mm countersunk screws.

Now fit the door handle with 25mm round head screws, diagram 38.

Slide the door glide onto the door guide bracket and then fix to the bottom of the door. Keep the down leg of the guide in line with the inside edge of the door, diagram 39.

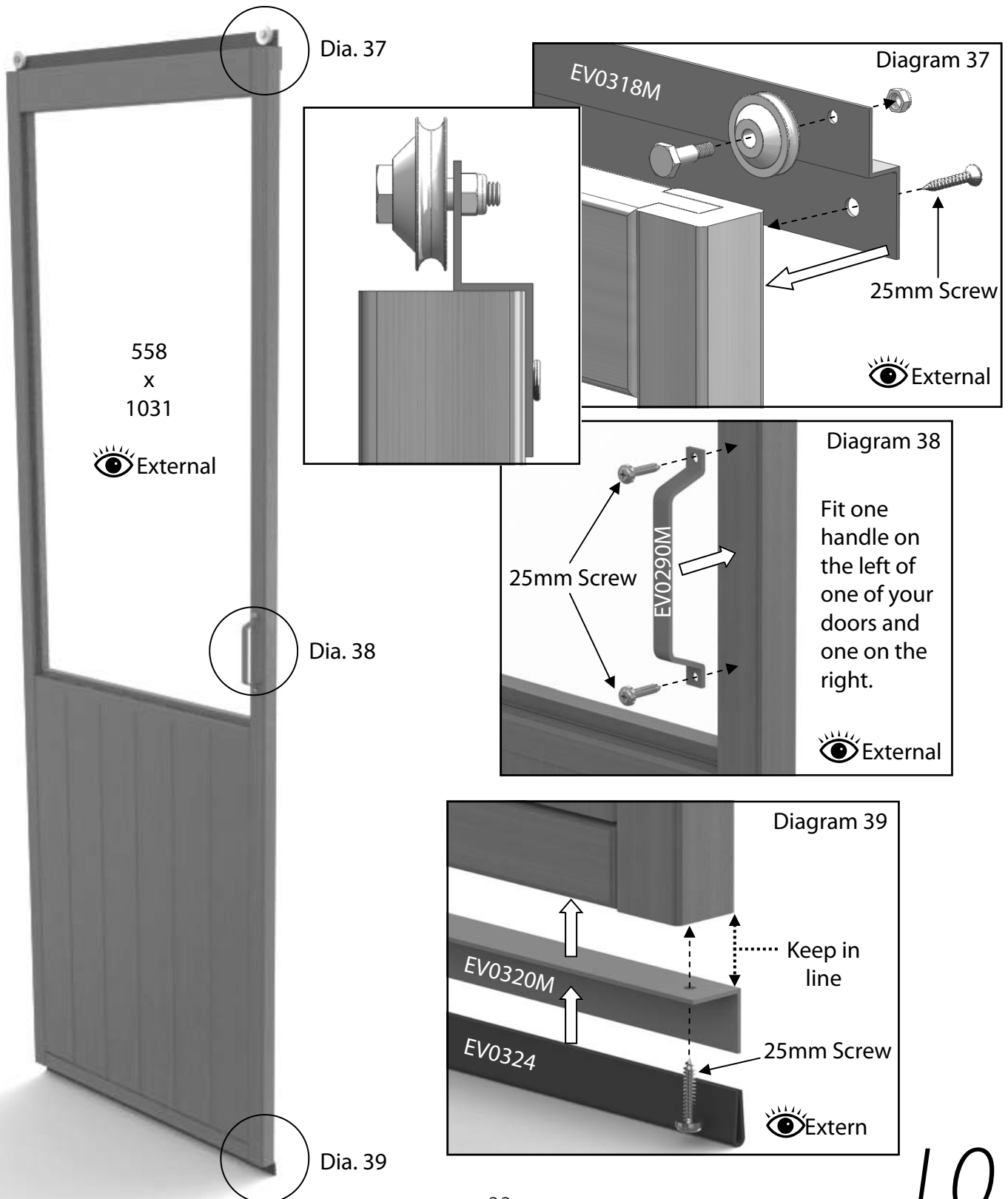

Door Installation

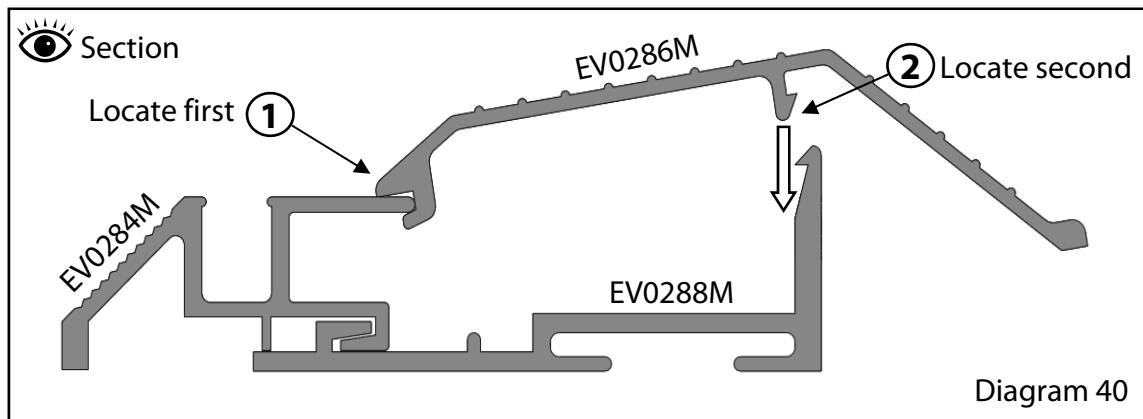

Next install the bottom door guide (EV0284M) onto the door cill (EV0288M) shown in diagram 40. Make sure the channels are free from grit and that this locates properly as you may find the next stage difficult if this is not the case.

Now fit the threshold section (EV0286M) in the middle of the door way. Locate the bottom edge of the threshold on the top lip of the door runner (point 1) and force the threshold down until it locks into place (point 2). You may find it easier to stand on this and walk along it or if you have a rubber mallet this is also a good tool for the job.

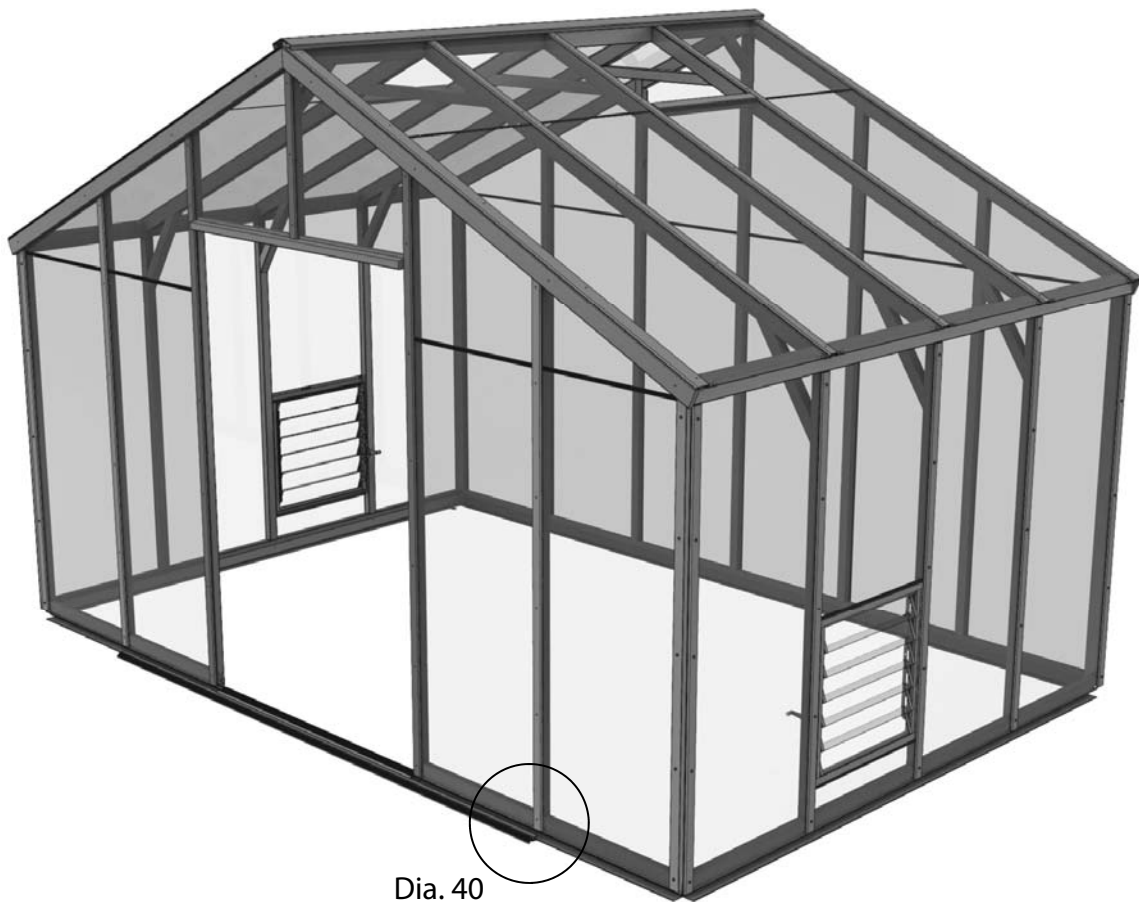

Door Installation

You can now fit the top door track to your building. The right hand end of the door track should be roughly inline with the outer edge of the glazing bar below it (circled below). With help slide the left hand door onto the track from the left hand end making sure the door wheels locate with the door track as shown in diagram 42, point 6. At the same time you need to locate the door guide with the door runner, point 7.

Holding the door up from the runner below so that it is just located in the runner (diagram 42, point 7) fix the track with the first 25mm screw at point 1 in diagram 41. The top edge of the door track should be close to the top edge of the door header (NOT above as this may cause water to pool).

Next slide the right hand door onto the track, again adjust the position of the track until you are happy with its location and fix with a 25mm screw at point 2.

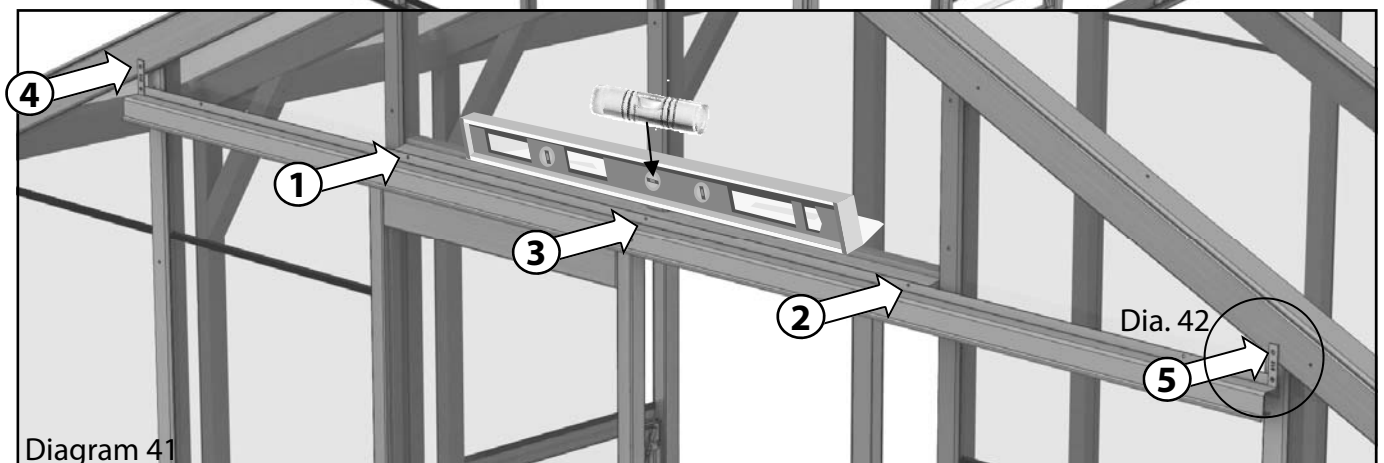
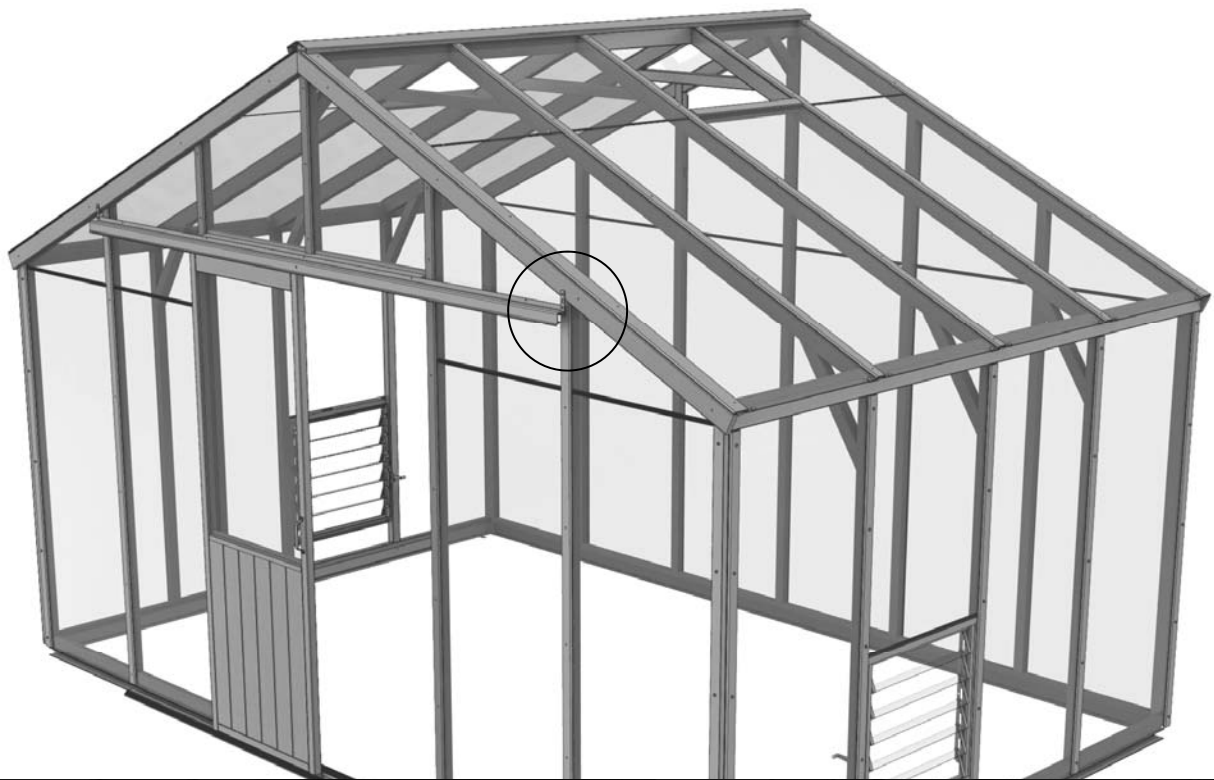
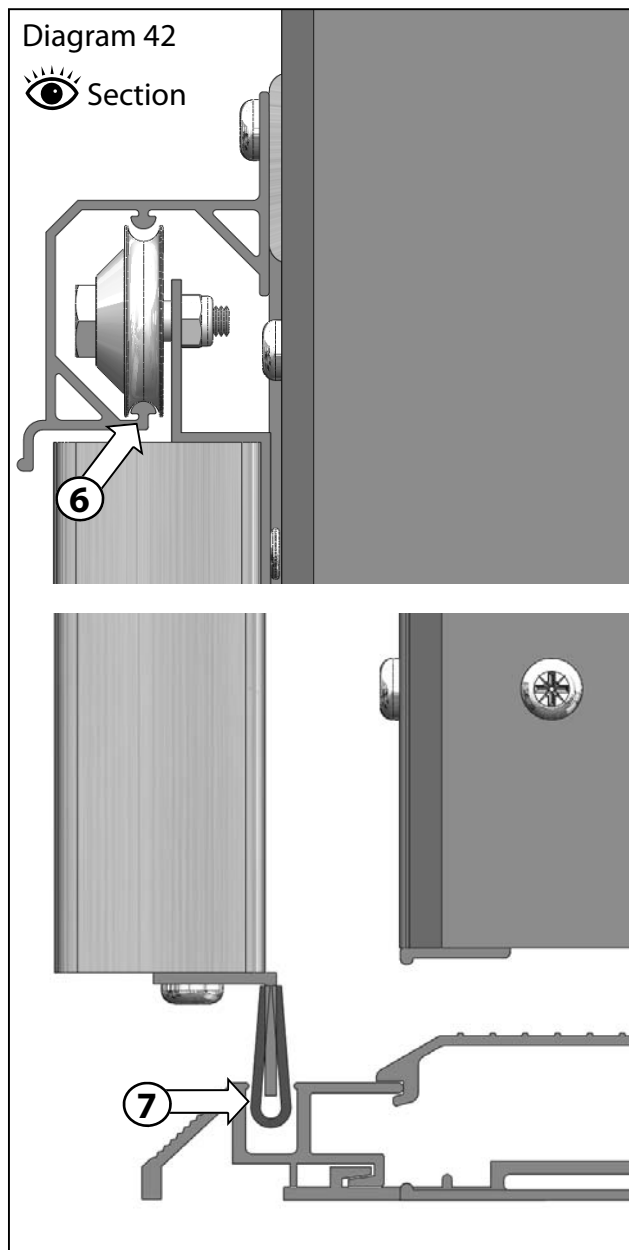

Diagram 41



Door Installation



You may find that the door height may need adjusting slightly. Do this by taking out the first screws you installed and reposition the track slightly, then re-fix.

Once you are happy with the position of your track and the door is running freely fix the middle screw to the track point 3.

Finally attach the vertical supports to each end with a 10mm nut and bolt, diagram 43. Using a spirit level along the top of the door track secure with two 25mm screws through the bottom of the vertical support, point 4 and 5.

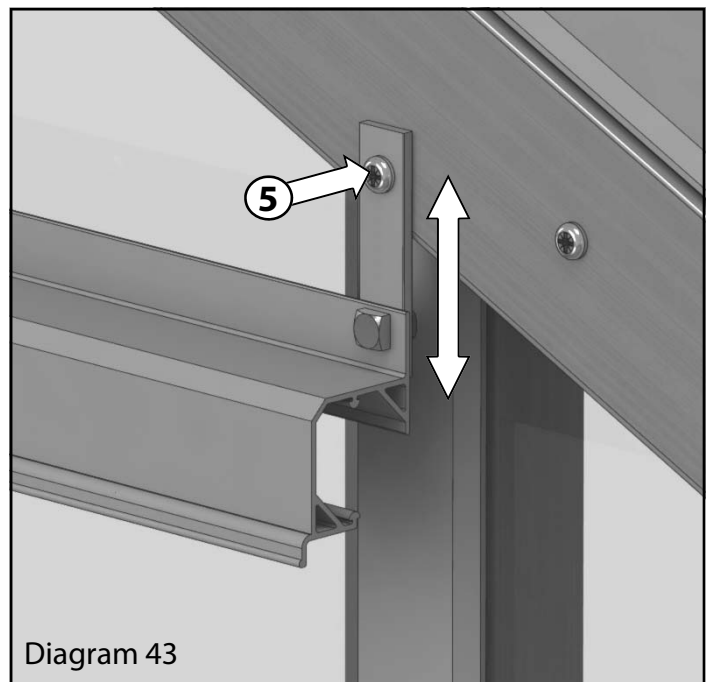

External

Door Installation

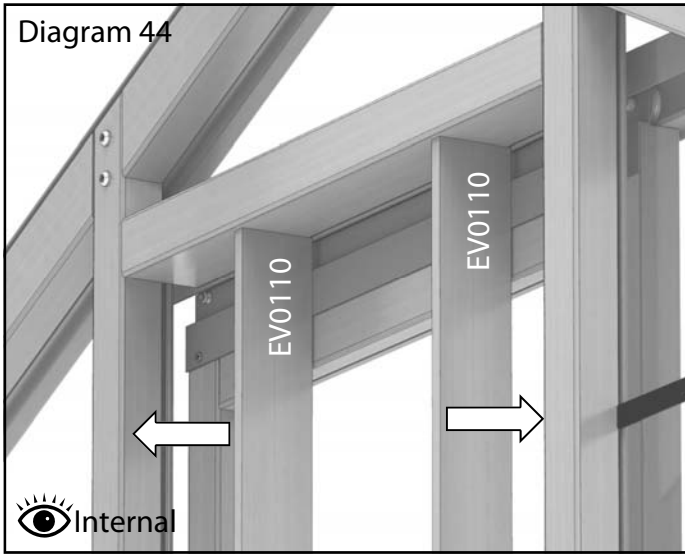

Standing on the inside of the greenhouse, with the door in the closed position you can install the door frame sides (diagram 43). Secure these with four 40mm screws per side. These should be fitted as close to the door as possible while still allowing it to pass by freely.

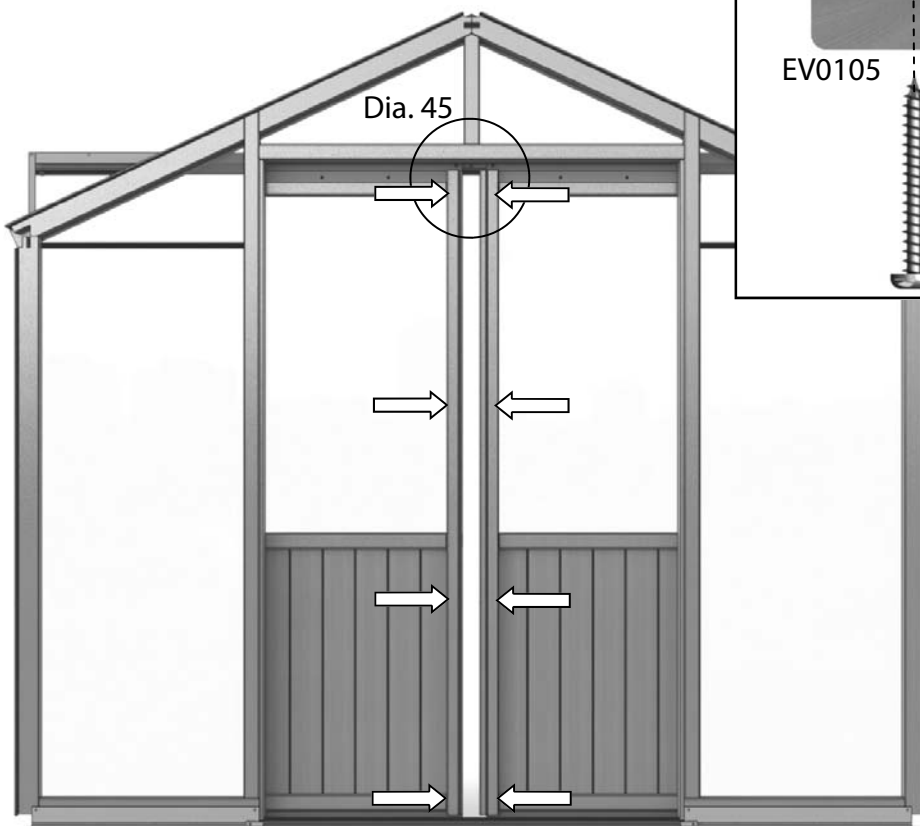
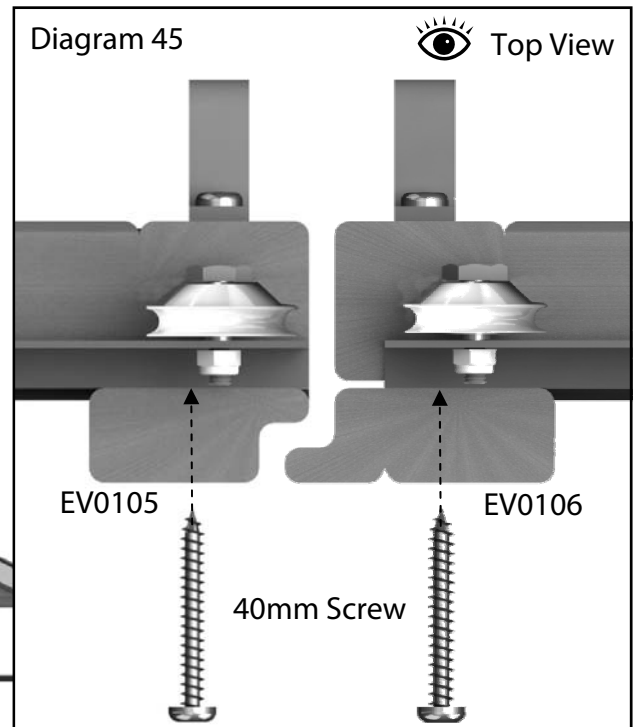

You can now install the rebate strips to the inside of your door. Pilot hole the strips first. It is best to do this away from the greenhouse with the 2 strips pinched together so you get the holes in the same positions. Drill 4 holes equally spaced then fix these with 40mm screws. Once the strips are in place you can fit the door handles on the inside, simply line these up with the handles on the outside of the door.

10

Roof Vent Installation

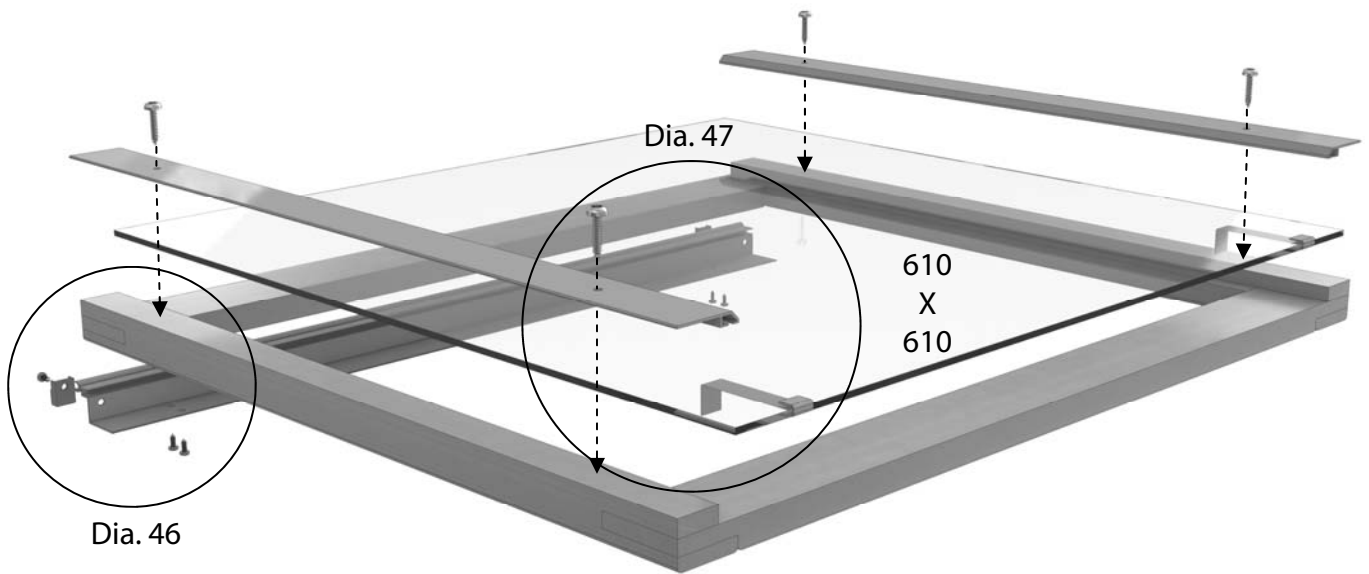

Take the vent frame that is ready assembled and fix the vent hinge to one end through the 4 pre drilled holes using the 19mm screws, diagram 46. Once this is in place fix the plastic vent filler (EV0323) also with a 19mm screw, its is **important** to make a pilot hole before fixing the plastic filler to prevent splitting.

Now take a 610mm x 610mm pane of glass and locate this in the vent hinge. Before lowering this down completely slot the glass stops onto the open edge.

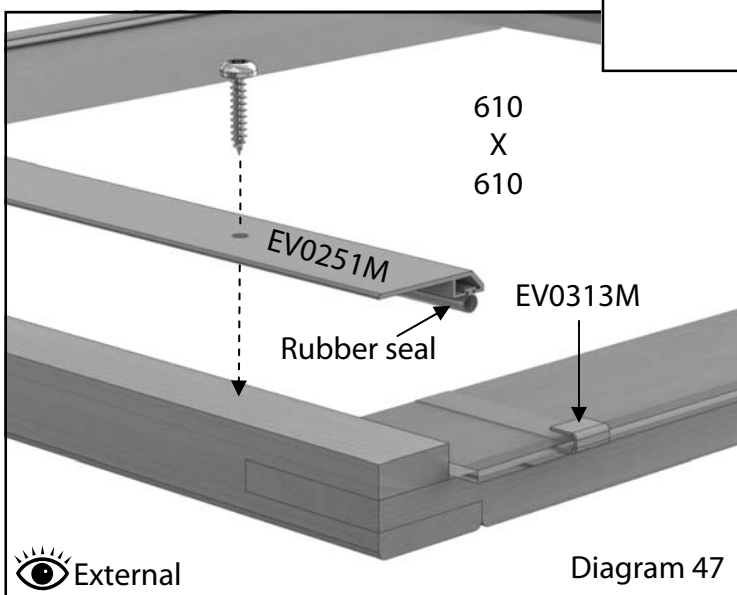
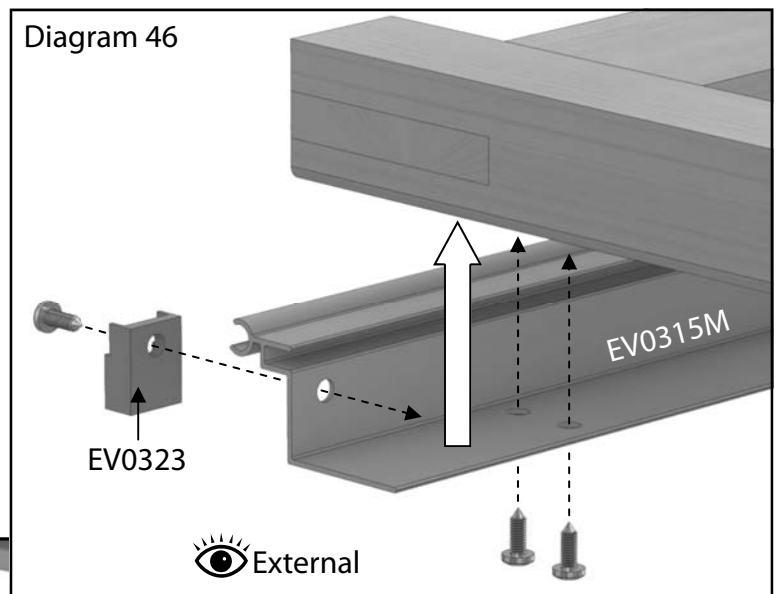

When in position you can fix the glass in place with the vent capping (either cedar or aluminium) using the 25mm screws, diagram 47. Remember if you are using the aluminium capping system you will need to insert the rubber seal before fixing it in place.

(Cedar capping part number: EV0151)



Roof Vent Installation (Aluminium capping option only)

If you have chosen the aluminium moss capping you will have been supplied roof vent filler strips (EV0322)

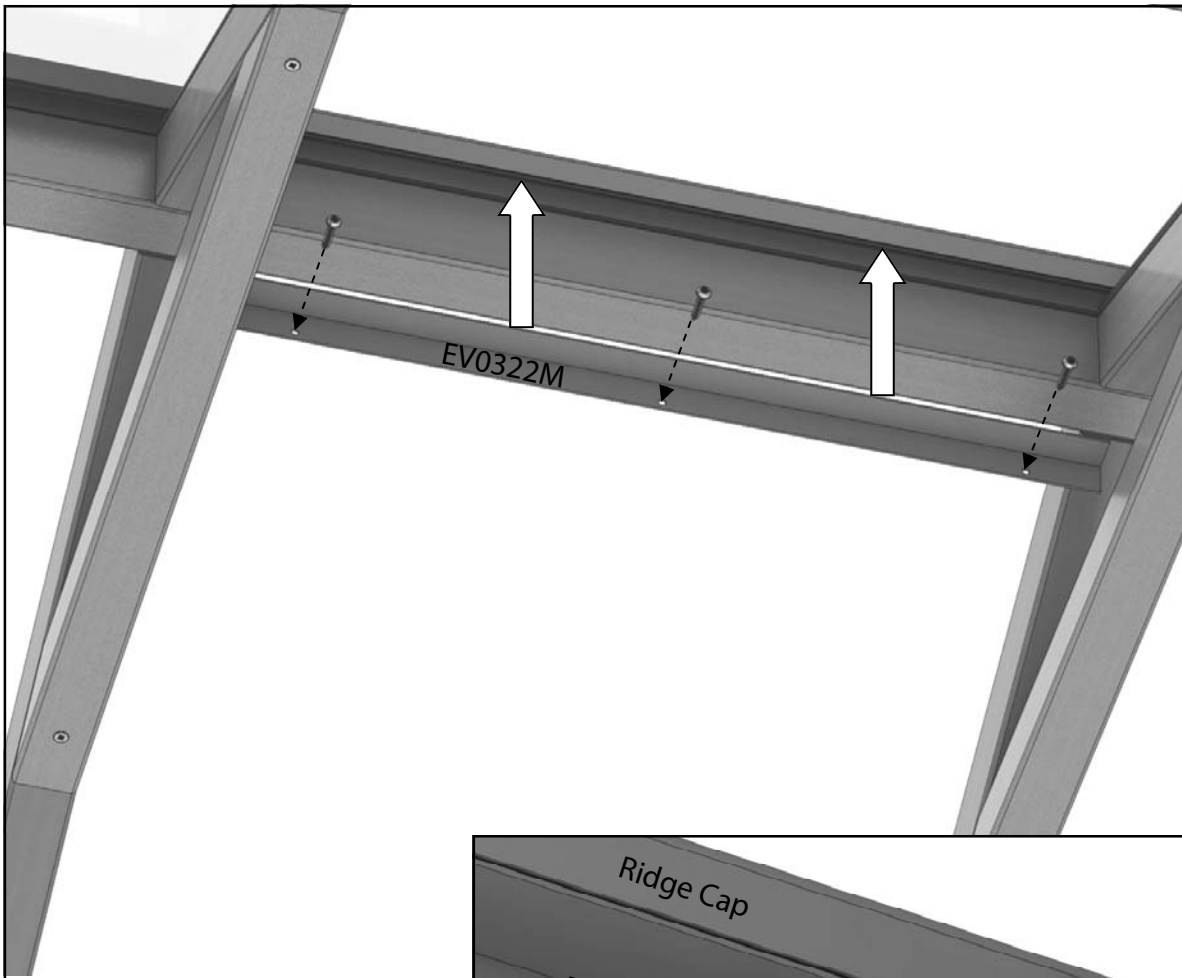

Fix these under the aluminium ridge cap with three 25mm screws. When in place silicone the two ends to seal any remaining gaps.

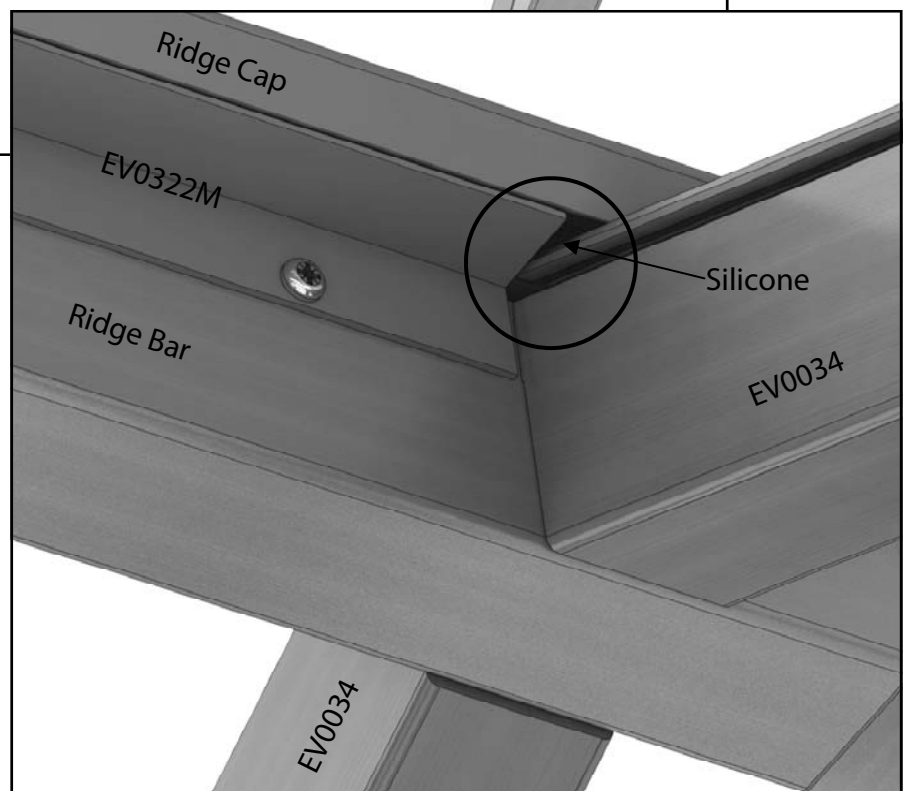

Roof Vent Installation

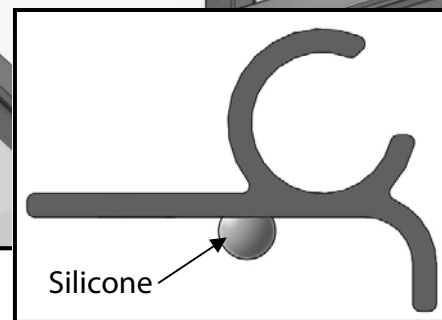
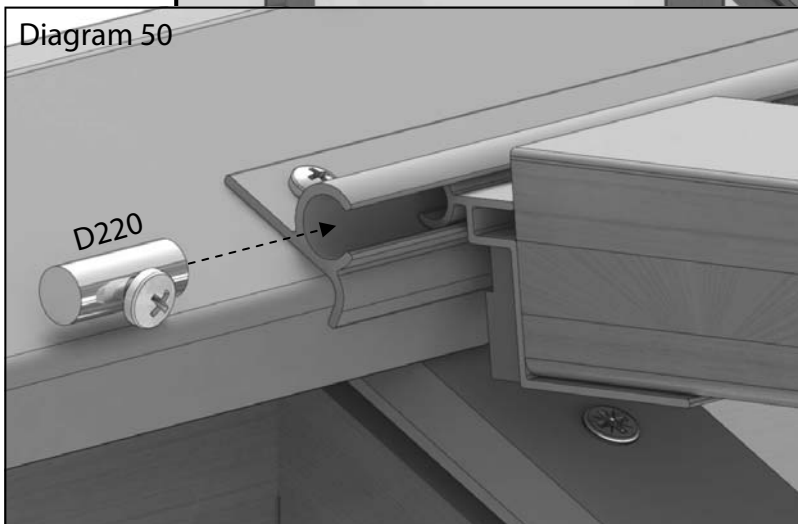
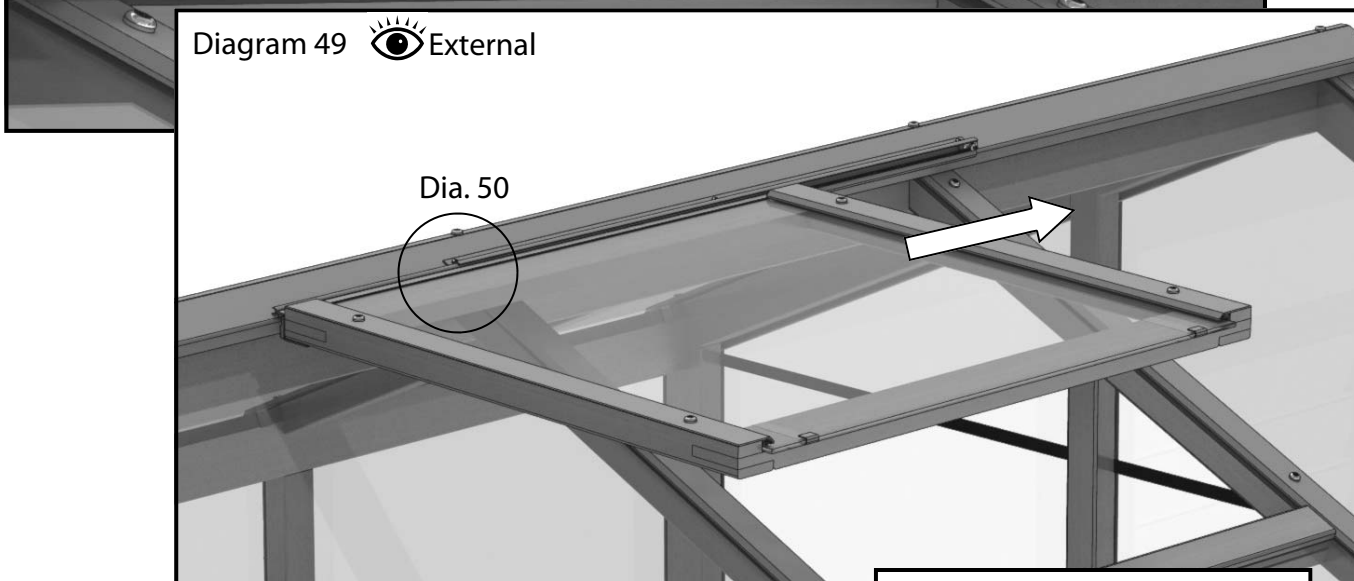
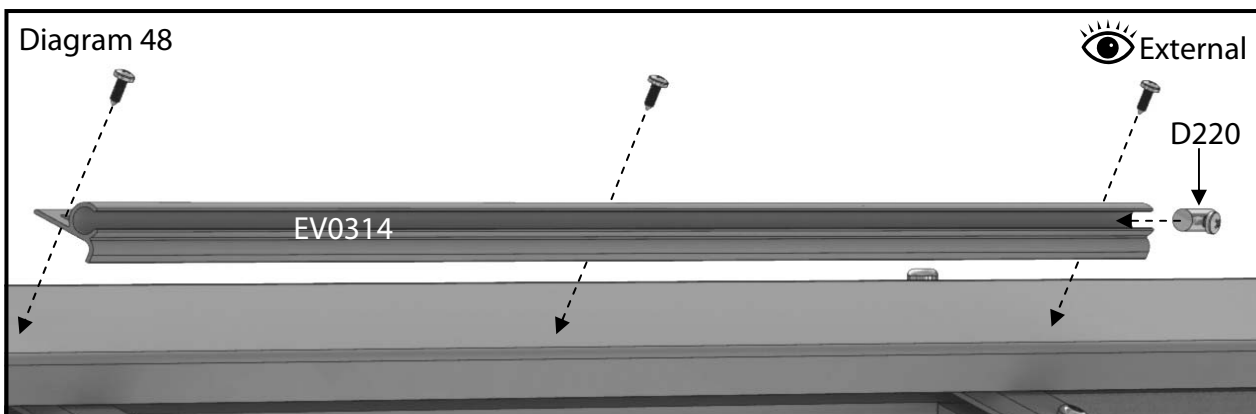

Once you have assembled the roof vents you can now install them to your building. Prepare the ridge hinge (EV0314) by running a bead of silicone along the back edge.

Then position this spaced equally over the opening in the roof. If you have the aluminium ridge cover then use the 13mm self tapping screws, if it is the cedar ridge cover just use the standard 19mm screws. Secure one of the vent stops (D220) at one end of the ridge hinge channel.

Next slide the roof vent along the channel of the ridge hinge and secure with another vent stop, diagram 49 and 50. You can now lower the vent until it rests on the roof bars.



Frame Finishing

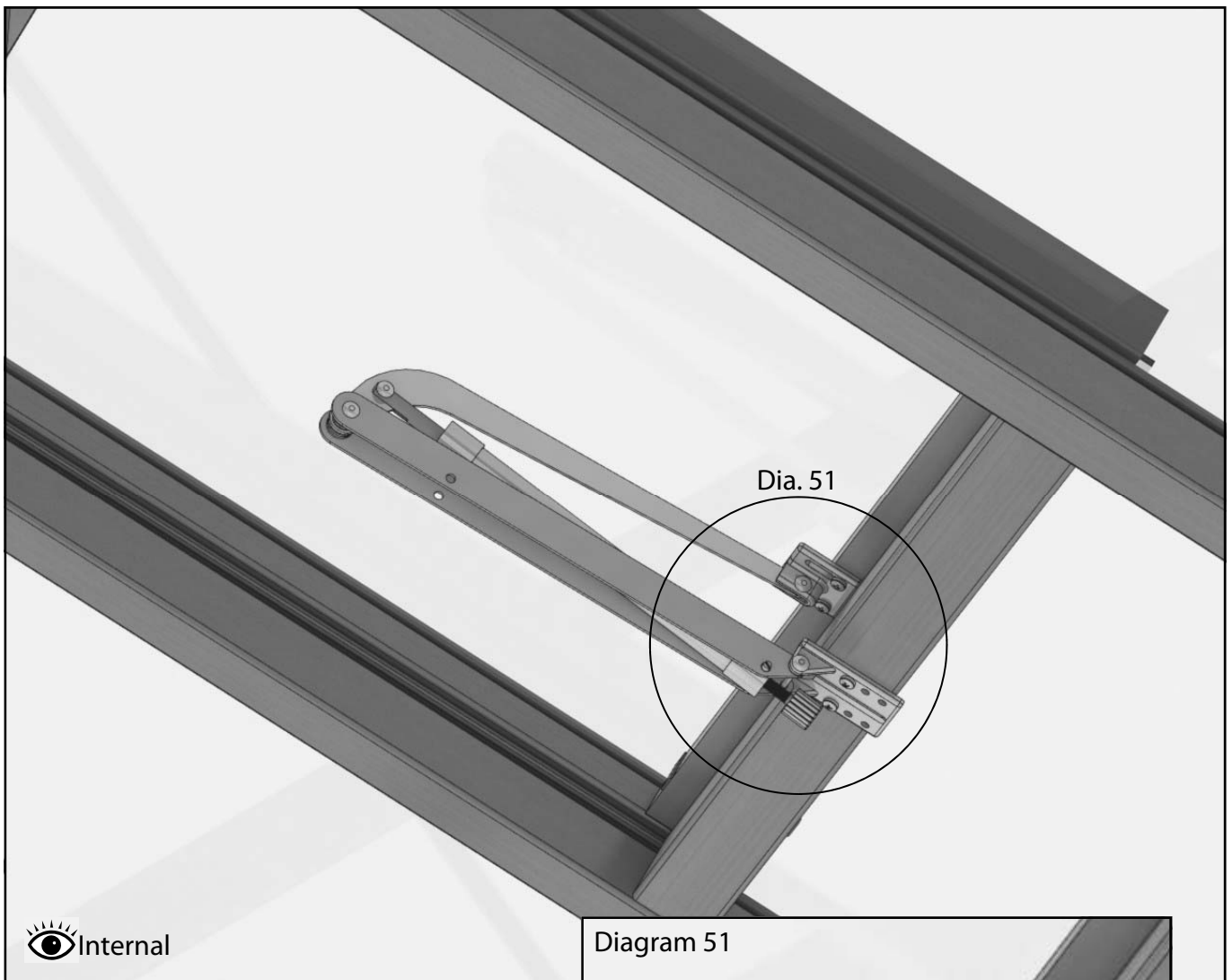

Now fit your autovents to the slam rail and to the bottom of the roof vents, diagram 51. Use 19mm screws to secure the top arm of the autovent to the roof vent, do this with the roof vent in the closed position so that you get the bracket in the correct position.

Adjust the lower arm on the slam rail until the arms of the autovent are as inline with the roof as possible, then fix with 25mm screws.

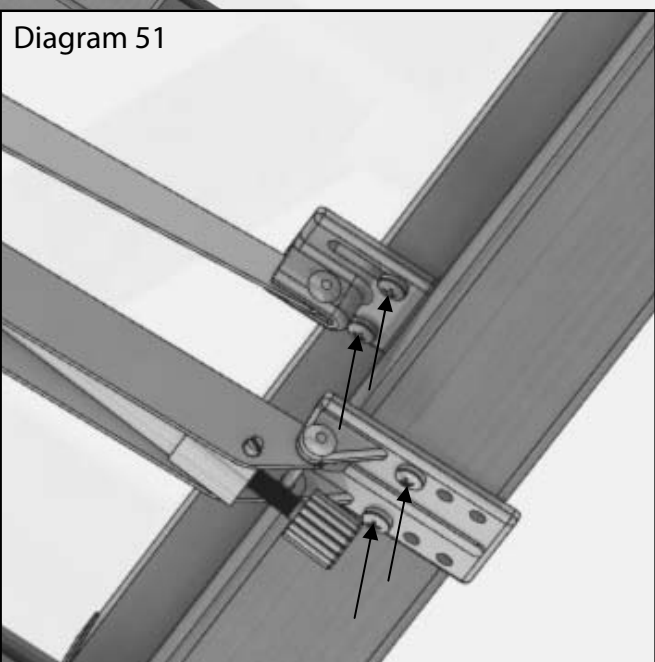

Gutter and Downpipe Installation

Fit the ridge end caps to your greenhouse with the four 25mm nails provided. Line this up with the top edges of the ridge cover cap. The nails should secure in the cloaking strip on the front (diagram 52).

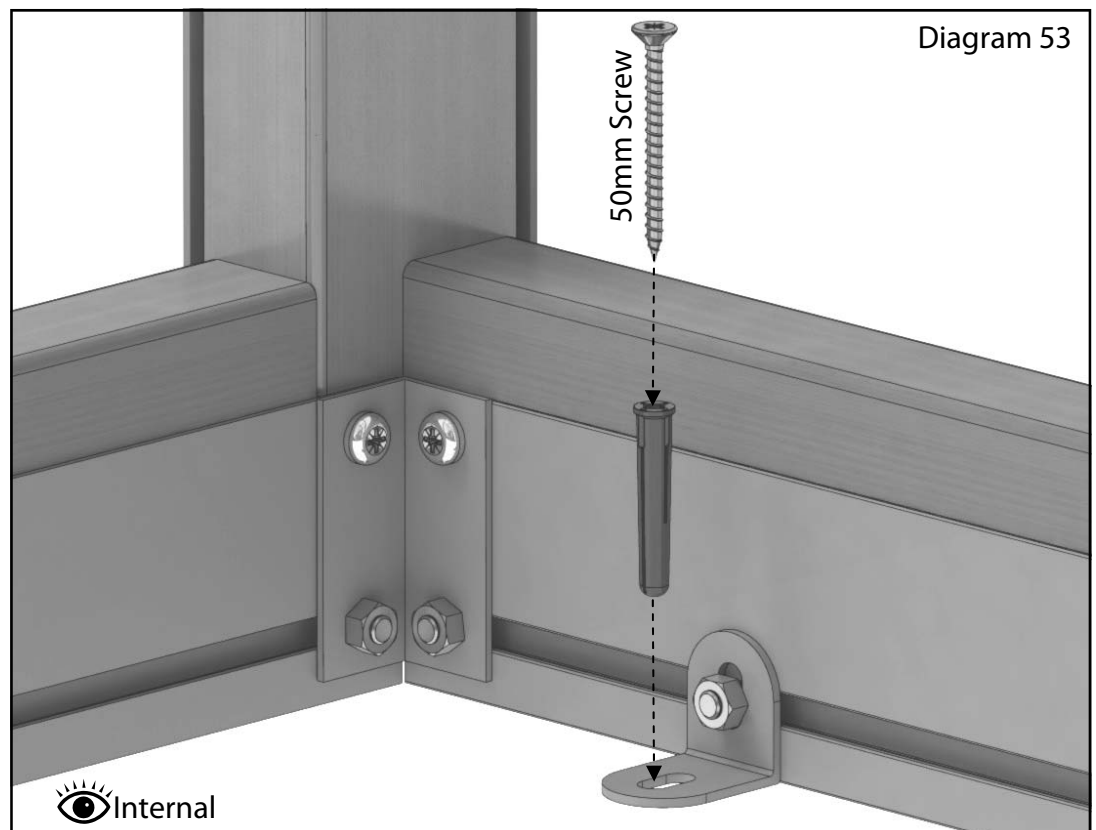
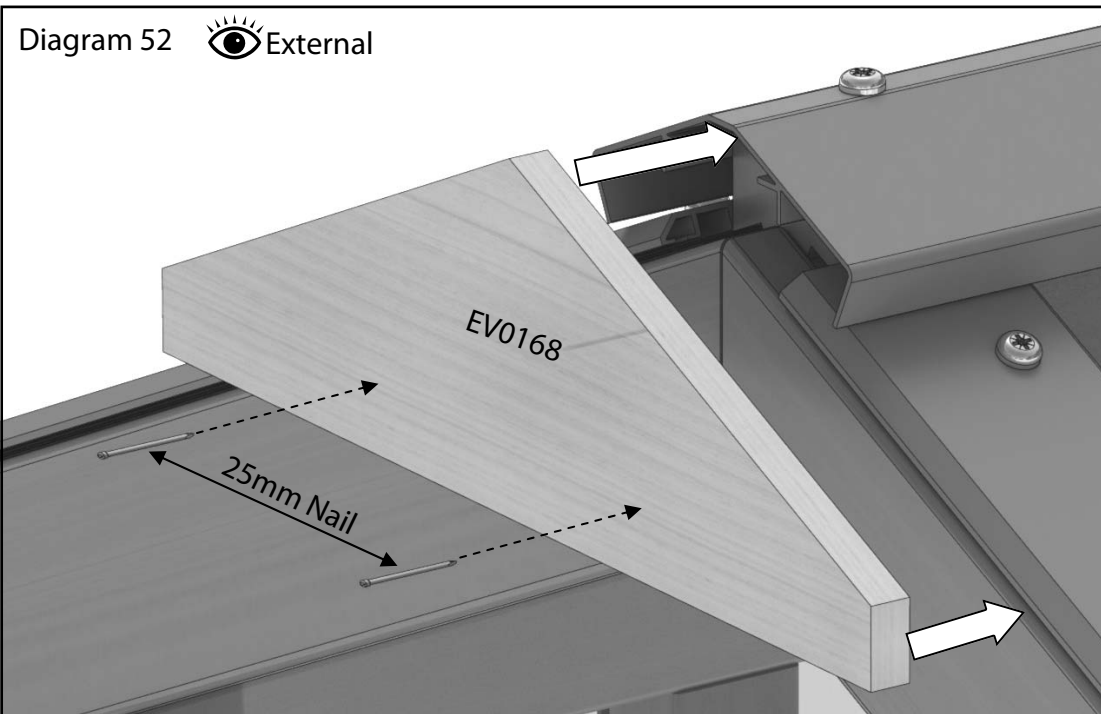

When you are happy with the final position of your greenhouse and all the sides are vertical and square you can fix the greenhouse to the ground. Use brown rawl plugs and 50mm screws to secure it through the base brackets previously attached (diagram 53).

Gutter and Downpipe Installation

Start installing your gutter by inserting the stop end in one end. It is a good idea to secure this with a clear silicone. With help or the aid of a prop take the gutter to the greenhouse and fix the end with the stop end in, using a 25mm screw. This should be installed as high as possible on the side of the greenhouse to allow for a good fall when fixing the other end (diagram 54).

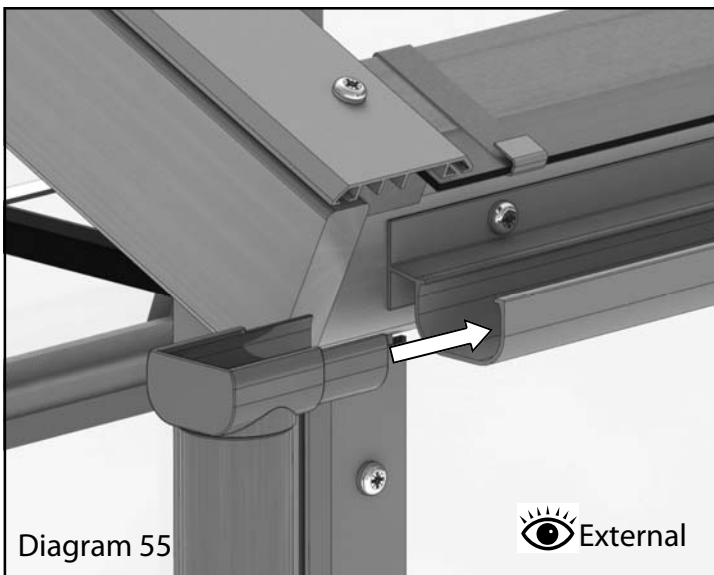
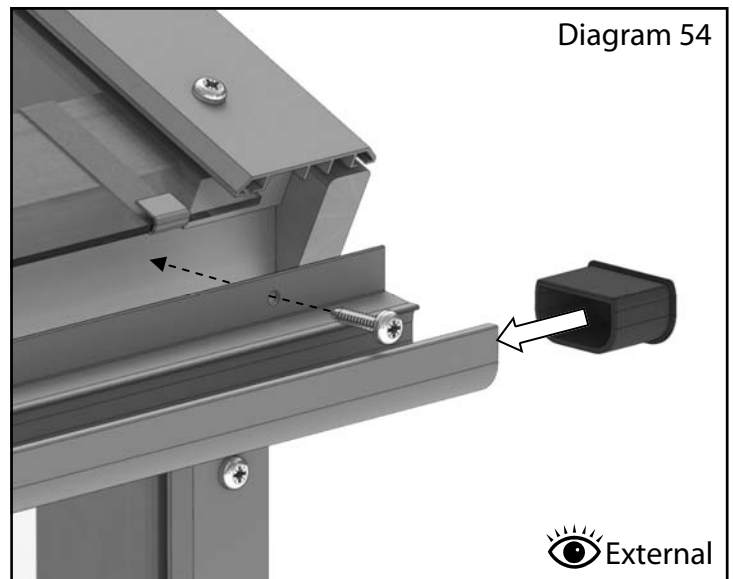

Now fix the other end of the gutter slightly lower than the first end. If you place a spirit level in the gutter it would ideally be just over the tip of the bubble.

Once this is fixed you can now secure the gutter through the other fixing points.

Fit the gutter outlet to the downpipe and then to the gutter, again using clear silicone if necessary.

It is a good idea to support the downpipe once you have fitted it to the outlet as it is likely to drop off before you fit the downpipe bracket.

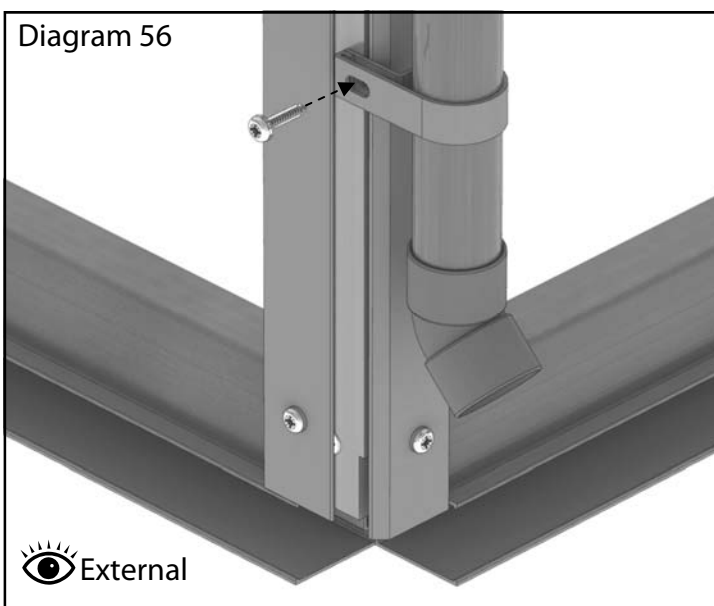

The downpipe bracket can be fitted at any point up and down the side corner bar to suite your situation, use a 25mm screw to fix this. Attach the 45 degree bend at the bottom of the downpipe to direct the water away from the greenhouse.

If you are installing a water butt simply cut the downpipe above the level of the water butt and attach the 45 degree bend and some of the off cut to direct the water into the butt.

Gutter and Downpipe Installation

Once the louvre is installed in the greenhouse you can replace the manual handle with the automatic unit.

First of all remove the screw to release the arm (diagram 57).

Next Remove the handle from the frame of the louvre (diagram 58).

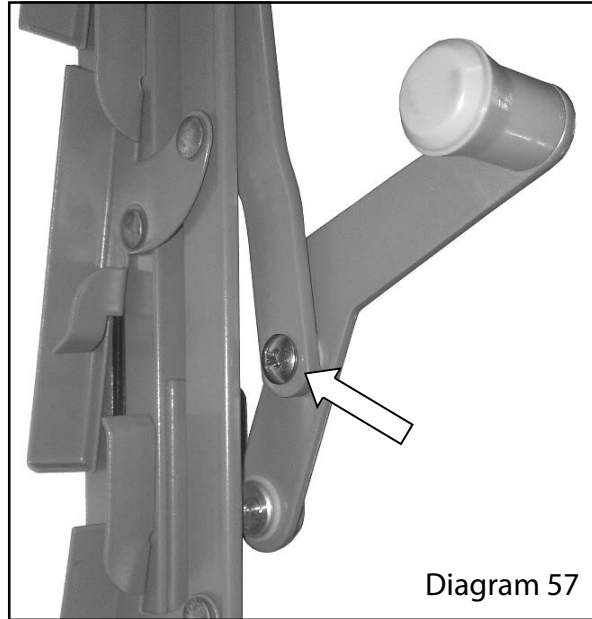

Diagram 57

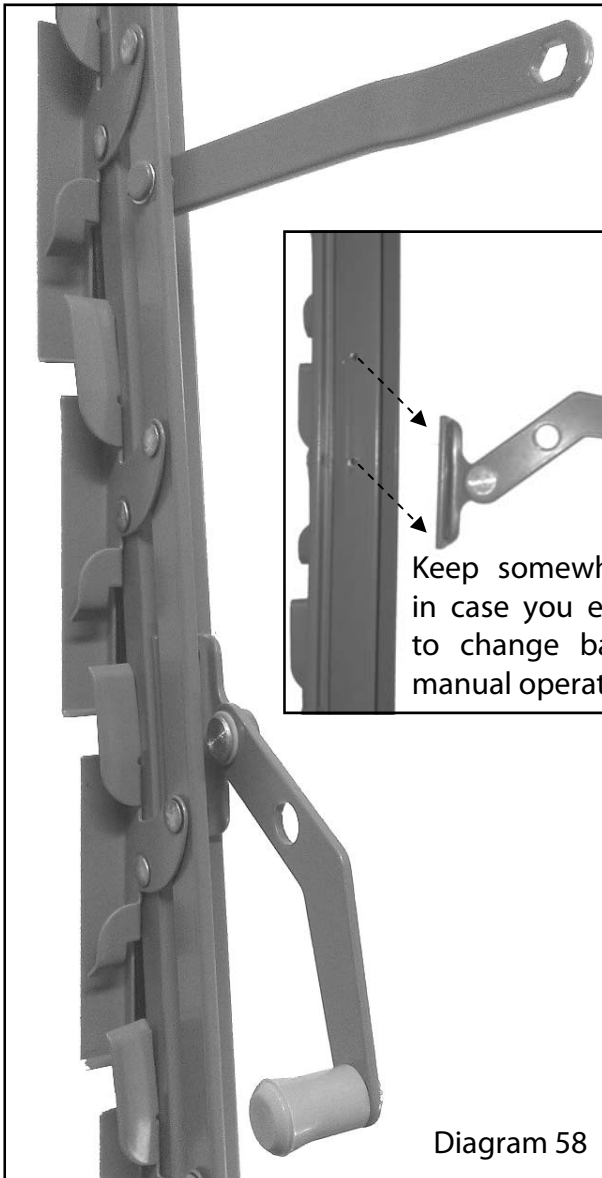

Diagram 58

Diagram 59 shows the parts you need to attach the auto opener.

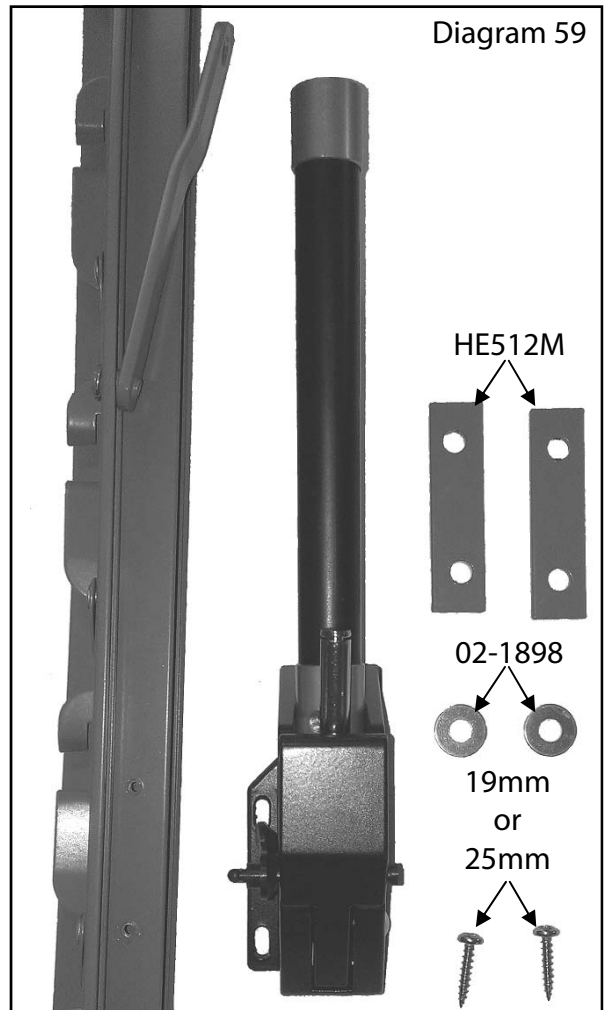

Diagram 59

Gutter and Downpipe Installation

You now need to mark the frame to drill the 2 holes, use a 2.5mm drill bit for this.

Offer the opener up to the frame with the plates and washers and slide the louvre arm into position. This now gives you the correct location for the opener (diagram 60). Once you have marked the frame remove the opener to drill the holes.

Now fix the opener to the frame using the 2 plates and 2 washers (diagram 61). You should have either 19mm or 25mm screws spare from the greenhouse frame for this.

Once fixed in place attached the louvre arm to the opener and hold in place with the plastic pop-on cap (diagram 62).

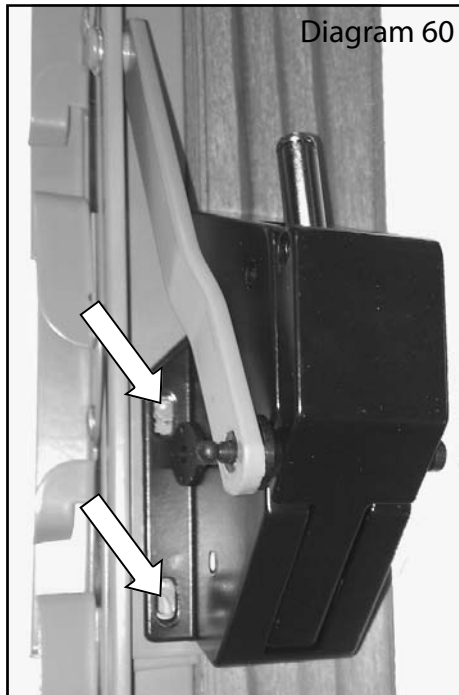

Diagram 60

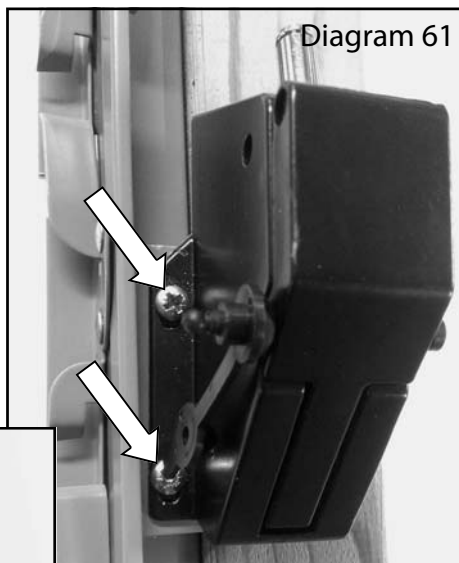

Diagram 61

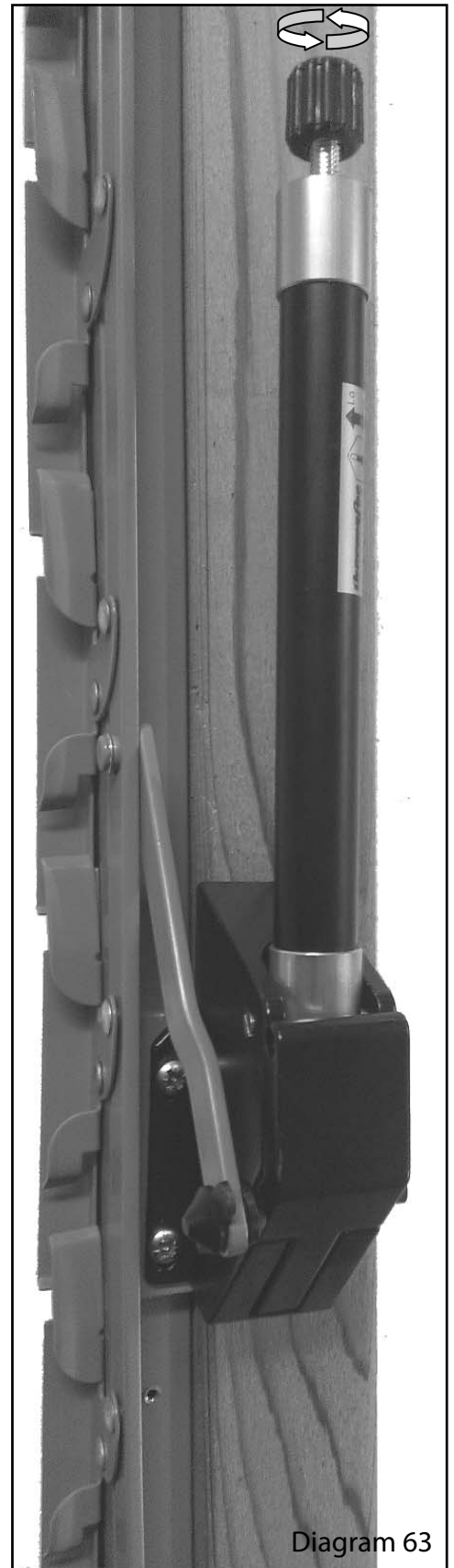

Diagram 63

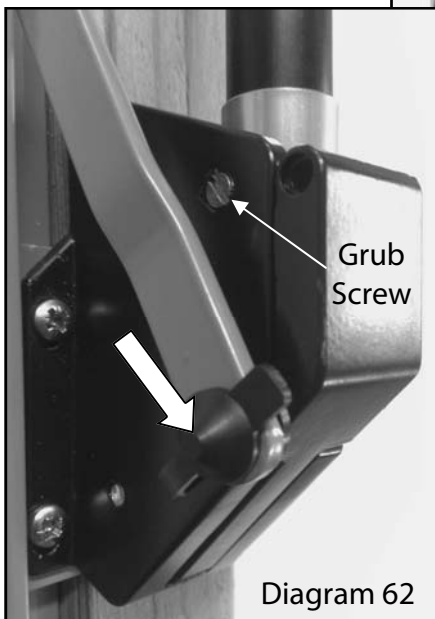

Diagram 62

Now slide the cylinder onto the shaft attached to the body of the opener, secure this in place with 2 grub screws (diagram 62).

Finally fit the thumb screw to the end of the cylinder, adjust this to get the desired amount of ventilation (diagram 63).

Parts Lists

Box 1

Part Code	Description	EVTWE126	EVTWE128	EVTWE1210	EVTWE1212
EV0024	Eaves Spacer	6	8	10	12
EV0035	Glazing Bar Roof 12ft wide	4	6	8	10
EV0090	Eaves Brace	4	6	8	10
EV0091	Ridge Brace	2	3	4	5
EV0105	Double door trim with rebate 1860mm RH	1	1	1	1
EV0106	Double door trim with rebate 1860mm LH	1	1	1	1
EV0168	Ridge End Cap	2	2	2	2
EV0296M	ALU Front Base 12ft wide	2	2	2	2
EV0301M	ALU Rear Base 12ft wide	1	1	1	1
EV0313M	Glass Stop	12	16	20	24
EV SMA01	SMALLS PACK NO 01	1	1	1	1
EV SMA02	SMALLS PACK NO 02		1	1	1
EVSPACEIGDOOM	Double Door Bundle	1	1	1	1
EVSMADD	EVOLUTION DOUBLE DOOR SMALLS PACK	1	1	1	1
EV PACVENT	Vent pack bundle for Evo	1	2	3	4
THAUTO	CLASSIC AUTO-VENT	1	2	3	4
HE512M	Cill joining bracket	2	2	2	2
ROSEPS	Glass separators 4mm black	10	10	10	10

Box 2

Part Code	Description	EVTWEGAB
EV0008	Cill Front Gable 12ft wide	2
EV0013	Cill Rear Gable 12ft wide	1
EV0044	Glazing Bar Roof Corner R 12ft wide	2
EV0045	Glazing Bar Roof Corner L 12ft wide	2
EV0054	Roof Corner Cloaking R 12ft wide	2
EV0055	Roof Corner Cloaking L 12ft wide	2
EV0056	Glazing Bar Side Corner R	2
EV0057	Glazing Bar Side Corner L	2
EV0060	Glazing Bar Gable R 6ft + 8ft wide	2
EV0061	Glazing Bar Gable L 6ft + 8ft wide	2
EV0064	Glazing Bar Gable R 12ft wide	1
EV0065	Glazing Bar Gable L 12ft wide	1
EV0072	Glazing Bar Door Gable R 12ft wide	1
EV0073	Glazing Bar Door Gable L 12ft wide	1
EV0076	Glazing Bar Gable Mid 12ft wide	1
EV0079	Glazing Bar Above Door 12ft wide	1
EV0092	Gallows Brace	2
EV0109	Door Header Double	1
EV0110	Door Frame Side	2

Parts Lists

Box 3

Part Code	Description	EVHOU4	EVHOU6	EVHOU8	EVHOU10	EVHOU12
EV0014	Cill Side 4ft long	2				
EV0015	Cill Side 6ft long		2			
EV0016	Cill Side 8ft long			2		
EV0017	Cill Side 10ft long				2	
EV0018	Cill Side 12ft long					2
EV0019	Eaves Bar 4ft long	2				
EV0020	Eaves Bar 6ft long		2			
EV0021	Eaves Bar 8ft long			2		
EV0022	Eaves Bar 10ft long				2	
EV0023	Eaves Bar 12ft long					2
EV0025	Ridge Bar 4ft long	1				
EV0026	Ridge Bar 6ft long		1			
EV0027	Ridge Bar 8ft long			1		
EV0028	Ridge Bar 10ft long				1	
EV0029	Ridge Bar 12ft long					1
EV0030	Glazing Bar Side	2	4	6	8	10
EV0234M	ALU Gutter 4ft long	2				
EV0235M	ALU Gutter 6ft long		2			
EV0236M	ALU Gutter 8ft long			2		
EV0237M	ALU Gutter 10ft long				2	
EV0238M	ALU Gutter 12ft long					2
EV0302M	ALU Side Base 4ft long	2				
EV0303M	ALU Side Base 6ft long		2			
EV0304M	ALU Side Base 8ft long			2		
EV0305M	ALU Side Base 10ft long				2	
EV0306M	ALU Side Base 12ft long					2
EV0325	Evolution complete louvre kit	1	1	1	2	2
EVRWK	Rainwater kit for Alton Evolution	1	1	1	1	1

Parts Lists

Box 4 Cedar Capping

Part Code	Description	EVTWECAP C126	EVTWECAP C128	EVTWECAP C1210	EVTWECAP C1212
EV0140	Side Capping	8	10	12	14
EV0145	Roof Capping 12ft wide	4	6	8	10
EV0150	Roof Corner Capping 12ft wide	4	4	4	4
EV0151	Roof Vent Capping	2	4	6	8
EV0152	Side Corner Capping R	2	2	2	2
EV0153	Side Corner Capping L	2	2	2	2
EV0156	Gable 6 Capping R	2	2	2	2
EV0157	Gable 6 Capping L	2	2	2	2
EV0160	Gable 12 Capping R	2	2	2	2
EV0161	Gable 12 Capping L	2	2	2	2
EV0164	Gable Mid 12 Capping	1	1	1	1
EV0167	Above Door 12 Capping	1	1	1	1
EV0169	Ridge Cover Cap 4ft long				2
EV0170	Ridge Cover Cap 6ft long	2			
EV0171	Ridge Cover Cap 8ft long		2		
EV0172	Ridge Cover Cap 10ft long			2	
EV0174	Ridge Cover Cap Extension 8ft long				2
02-1356	Clear Silicone	5			
02-1356	Clear Silicone		6		
02-1356	Clear Silicone			7	
02-1356	Clear Silicone				7

Parts Lists

Box 4 Optional Aluminium Capping

Part Code	Description	EVTWECAP A126M	EVTWECAP A128M	EVTWECAP A1210M	EVTWECAP A1212M
EV0240M	ALU Side Capping	8	10	12	14
EV0245M	ALU Roof Capping 12ft wide	4	6	8	10
EV0250M	ALU Roof Corner Capping 12ft wide	4	4	4	4
EV0251M	ALU Roof Vent Capping	2	4	6	8
EV0252M	ALU Side Corner Capping R	2	2	2	2
EV0253M	ALU Side Corner Capping L	2	2	2	2
EV0256M	ALU Gable 6 Capping R	2	2	2	2
EV0257M	ALU Gable 6 Capping L	2	2	2	2
EV0260M	ALU Gable 12 Capping R	2	2	2	2
EV0261M	ALU Gable 12 Capping L	2	2	2	2
EV0264M	ALU Gable Mid 12 Capping	1	1	1	1
EV0267M	ALU Above Door 12 Capping	1	1	1	1
EV0270M	ALU Ridge Cover Cap 6ft long	1			
EV0271M	ALU Ridge Cover Cap 8ft long		1		
EV0272M	ALU Ridge Cover Cap 10ft long			1	
EV0273M	ALU Ridge Cover Cap 12ft long				1
EV0322M	Aluminium under vent filler	1	2	3	4
EV0231	100m roll of glazing PVC	1	1	1	2
EV0227	10m roll of glazing PVC		3	5	

Notes...

Notes...



Helpline 0116 267 7091

www.birstall.com alton@birstall.com