

Grosfillex®



ABRI DECO H7

2630 X 2630

VW27-1312



**NOTICE DE MONTAGE • ASSEMBLY INSTRUCTIONS • AUFBAUANLEITUNG
ISTRUZIONI PER IL MONTAGGIO • MANUAL DE MONTAJE • MONTAGE INSTRUCTIES
FOLHETO DE MONTAGEM**

RECOMMANDATIONS

RECOMMENDATIONS • EMPFEHLUNGEN • RACCOMANDAZIONI • RECOMENDACIONES • AANBEVELINGEN • RECOMENDAÇÕES

F

Nous vous remercions d'avoir choisi l'abri : la Maison de Jardin GROSFILLEX.

Nous vous recommandons de lire complètement cette notice de montage avant de procéder à la construction de votre abri.

Bien conserver la facture datée et la notice pour obtenir des références futures et pour les réclamations comprises dans la garantie.

- La surface de l'endroit désigné doit être parfaitement plane.

- Les éléments de l'abri doivent être stockés à plat.

- Ne déballer les colis qu'au moment du montage.

- Le montage est à faire par 2 personnes dans la journée si possible.

- Ne pas réaliser la construction de votre abri les jours de GRAND VENT ou de GRAND FROID.

- Pour le toit ou les murs, ne pas utiliser de toile ou plaques bitumeuses ou de peintures foncées.

- Pour éviter la déformation de votre abri, ne déposez pas d'objets lourds contre les parois.

- Pour une étanchéité parfaite, vous pouvez déposer un joint en silicone à la base de votre abri.

- Le toit doit être toujours propre et dégagé de la neige et des feuilles. De grandes quantités sur le toit pourraient l'abîmer et l'accès intérieur devenir dangereux.

- Pour laver votre abri, utilisez un tuyau d'arrosage avec un détergent doux car l'utilisation d'une brosse dure ou d'un produit abrasif risquerait de l'endommager.

- NE JAMAIS MONTER SUR LE TOIT.

- Les autorités locales ou régionales vous diront si un permis est nécessaire pour la construction de votre abri. N'oubliez pas de les consulter.

GB

Thank you for choosing a GROSFILLEX Maison de Jardin shed.

We recommend that you read these assembly instructions in full before building your shed.

Please keep your dated invoice and the instructions for future reference and for claims covered by the guarantee.

- The surface of the chosen location must be completely level.

- The shed parts must be stored flat.

- Only unpack packages at the time of assembly.

- Assembly should be carried out by 2 people during the daytime if possible.

- The windows may be installed on any wall panel. Decide on the location before starting assembly.

- Do not construct your shed on VERY WINDY or VERY WET days.

- Do not use canvas, asphalt patches or dark paint for the roof or walls.

- To avoid your shed's shape from distorting, do not place heavy objects against the wall.

- You can put silicone joint sealer around the base of your shed for complete waterproofing.

- The roof should always be clean and free of snow and leaves. Heavy objects on the roof could damage it and it could become dangerous to go inside.

- To wash your shed, use a hosepipe with a soft detergent because using a hard brush or an abrasive product might risk damaging it.

- NEVER CLIMB ON THE ROOF.

- Local or regional authorities will tell you if you require planning permission to build your shed. Do not forget to consult them.

D

Wir bedanken uns für Ihr Vertrauen, und dafür, dass Sie sich für ein Gartenhaus / Gerätehaus aus dem Hause Grosfillex entschieden haben.

Wir empfehlen Ihnen, diese Aufbauanleitung zunächst sorgfältig zu lesen und dann Schritt für Schritt die Montage Ihres neuen Hauses vorzunehmen. Bitte bewahren Sie anschließend diese Anleitung, sowie Ihren Kaufbeleg sorgfältig auf um gegebenenfalls im Rahmen der Garantie oder im Falle von Reklamationen darauf zurückgreifen zu können.

- Die für den Aufbau bestimmte Stelle muss absolut eben und waagrecht sein, da Sie sonst kein einwandfreies Ergebnis der Montage erzielen können

- Die Einzelteile des Gartenhauses müssen bis zur Montage eben gelagert werden.
- Öffnen Sie die einzelnen Pakete erst, wenn Sie sie zur Montage benötigen
- Führen Sie die Montage mit 2 Personen und nach Möglichkeit innerhalb eines Tages durch

- Bei den Modellen H7 und H12 kann das seitliche Fenster frei nach Ihrer Wahl in einer der Seitenwände installiert werden. Treffen Sie diesbezüglich eine Entscheidung, bevor Sie mit der Montage beginnen

- Führen Sie die Montage des Gartenhauses nicht an Tagen durch, an denen EIN STARKER WIND herrscht oder es an denen es SEHR KALT ist

- Es dürfen weder für die Dacheindeckung, noch für die Wände Bitumengewebe, Bitumen-platten oder dunkle Farbanstriche verwendet werden

- Um eine Verformung des Gartenhauses zu vermeiden, dürfen Sie keine schweren Gegenstände an die Wände lehnen

- Wir empfehlen, die Fuge zwischen dem Grundrahmen des Gartenhauses und dem Untergrund mit Silikon abzudichten, um das Eindringen von Regenwasser an dieser Stelle zu vermeiden

- Das Dach sollte stets sauber und frei von Schnee und Blättern gehalten werden. Grosse Schneemengen oder Blätter könnten das Dach beschädigen und das Begehen des Gartenhauses gefährlich machen

- Zur Reinigung Ihres Gartenhauses, benutzen Sie bitte einen Gartenschlauch und, wenn nötig, ein sanftes Waschmittel. Die Benutzung einer harten Bürste oder eines Scheuermittels könnten zu Beschädigungen führen

- ES IST VERBOTEN, AUF DAS DACH ZU STEIGEN

- Bei Ihren lokalen oder regionalen Behörden erfahren Sie, ob eine Baugenehmigung für den Bau des Gartenhauses notwendig ist. Bitte wenden Sie sich an die entsprechenden Behörden.

I

La ringraziamo di aver scelto: la Home Garden GROSFILLEX.

Le consigliamo di leggere interamente le istruzioni per il montaggio prima di procedere alla costruzione. Conservi lo scontrino con la data e le istruzioni per ottenere future referenze e per eventuali reclami coperti dalla garanzia.

- La superficie deve essere perfettamente piana.

- Gli elementi devono essere disposti in piano.

- Aprire la confezione solo al momento del montaggio.

- Il montaggio necessita la presenza di due persone e deve essere fatto possibilmente in una giornata.

- Le finestre possono essere installate su tutti i pannelli dei muri laterali. Decidere dove porle prima di iniziare il montaggio.

- Non procedere al montaggio in giornate VENTOSE o FREDE.

- Per i tetti o i muri non usare tele o plastiche bitumate né pitture scure.

- Per evitare la deformazione della Home Garden non appoggiare oggetti pesanti alle pareti.

- Per una perfetta impermeabilità, è possibile applicare guarnizioni di silicone lungo la base.

- Il tetto deve essere sempre pulito e sgombrato da neve e foglie per evitare che questo si rovini e renda pericoloso l'accesso all'interno della Home Garden.

- Per pulire la casetta, usare un tubo con detersivo delicato (spazzole o prodotti abrasivi potrebbero danneggiarlo).

- NON SALIRE MAI SUL TETTO.

- Le autorità locali o regionali diranno se occorre un'autorizzazione per la costruzione. Non dimenticare di consultarle.

SP

Le damos las gracias por haber elegido el cobertizo de jardín: la Maison de Jardin GROSFILLEX.

Le recomendamos leer por completo este manual de montaje antes de proceder a la construcción del cobertizo. Conserve debidamente la factura fechada y el manual, para disponer eventualmente de referencias futuras y para las reclamaciones que están incluidas en la garantía.

- La superficie del lugar designado deberá estar perfectamente plana.

- Los elementos del cobertizo deben almacenarse de plano.

- Desembale únicamente los paquetes en el momento del montaje.

- El montaje deberán hacerlo 2 personas en el mismo día si fuera posible

- Las ventanas pueden instalarse en cualquier panel de las paredes laterales. Decida el lugar antes de empezar el montaje.

- No realice la construcción de su cobertizo los días que haya MUCHO VIENTO o MUCHO FRÍO.

- Para el techo o las paredes, no utilizar tejido o placas asfálticas ni pinturas oscuras.

- Para evitar la deformación del cobertizo, no deposite objetos pesados contra las paredes.

- Para una estanqueidad perfecta, puede añadir una junta de silicona en la base de su cobertizo.

- El techo debe mantenerse siempre limpio, sin nieve y sin hojas. Si hubiese mucho peso en el techo, se podría estropear y el acceso al interior resultaría peligroso.

- Para lavar su cobertizo, utilice una manguera con un detergente suave, ya que la utilización de un cepillo duro o de un producto abrasivo podría dañarlo.

- NO SUBIR NUNCA AL TEJADO.

- Las autoridades locales o regionales le dirán si es necesario un permiso para la construcción del cobertizo. No se olvide de consultarlas.

NL

Wij danken u voor uw aankoop van het GROSFILLEX tuinhuis.

Wij raden u aan om deze montage instructies grondig en volledig te lezen alvorens het tuinhuis te monteren.

Bewaar de gedateerde factuur zowel als de instructies zorgvuldig; ze kunnen van pas komen voor eventueel latere referenties en in geval van klachten gedekt door de garantie.

- De ondergrond van de gekozen locatie voor het tuinhuis moet volledig vlak zijn.

- De onderdelen van het tuinhuis moeten plat worden opgestapeld.

- Pak de colli slechts uit op het ogenblik van montage.

- De montage moet overdag en, indien mogelijk, door 2 personen gebeuren.

- De ramen kunnen op gelijk welk paneel in de zijmuren geïnstalleerd worden. Maak een keuze alvorens de montage te starten.

- Monteer het tuinhuis niet bij HEVIGE WIND of KOUDE.

- Gebruik voor het dak of de muren geen behang, bitumen platen of donkere verf.

- Om vervorming van de wanden te voorkomen, mogen er geen zware voorwerpen tegen worden geplaatst.

- Voor volledige waterdichtheid, brengt u langs de grondlijn van het tuinhuis best een siliconen voeg aan.

- Het dak moet steeds schoon zijn en vrij van sneeuw en bladeren. Grote gewichten op het dak kunnen schade aanrichten waardoor de toegang naar binnen gevaarlijk wordt.

- Gebruik bij het schoonmaken een tuinslang en zachte zeep want een harde borstel of bijtend middel zouden schade kunnen aanrichten.

- KRUIP NOOIT OP HET DAK.

- Bij de plaatselijke of regionale autoriteiten kunt u navraag doen naar de noodzaak van een toelating voor het opstellen van een tuinhuis. Vergeet ze niet te raadplegen.

P

Obrigado por ter escolhido o abrigo: a Casa de Jardim GROSFILLEX.

Recomendamos a leitura completa deste folheto de montagem antes de começar a construir o seu abrigo.

Conservar a factura com a data de compra para questões que se levantem cobertas pela garantia.

- A superfície do lugar escolhido tem que ser perfeitamente plana.

- As componentes do abrigo têm que ser armazenadas deitadas ao comprido.

- Abra as embalagens apenas na altura da montagem.

- A montagem tem que ser feita por 2 pessoas, preferencialmente com luz do dia.

- As janelas podem ser instaladas em qualquer painel das paredes laterais. Decida a sua localização antes de começar a montagem.

- Não efectuar a construção do seu abrigo em dias de MUITO VENTO ou de MUITO FRIO.

- Para o telhado ou os muros, não utilize tela ou placas betumadas nem pinturas escuras.

- Para prevenir a deformação do seu abrigo, não coloque objectos pesados contra as paredes.

- Para uma impermeabilidade perfeita, pode aplicar uma junta de silicone na base do seu abrigo.

- O telhado tem que estar sempre limpo, sem neve ou folhas. Grandes quantidades destas no telhado podem danificá-lo e o acesso ao seu interior pode tornar-se perigoso.

- Limpe o seu abrigo com uma mangueira e um detergente suave, pois o uso de uma escova dura ou de um produto abrasivo poderia danificá-lo.

- NUNCA SUBIR AO TELHADO.

- As autoridades locais ou regionais devem informá-lo se é necessário obter uma licença de obras para construir o seu abrigo.

OUTILLAGE

TOOLS • WERKZEUG • ATTREZZI • HERRAMIENTAS • GEREEDSCHAP • FERRAMENTAS

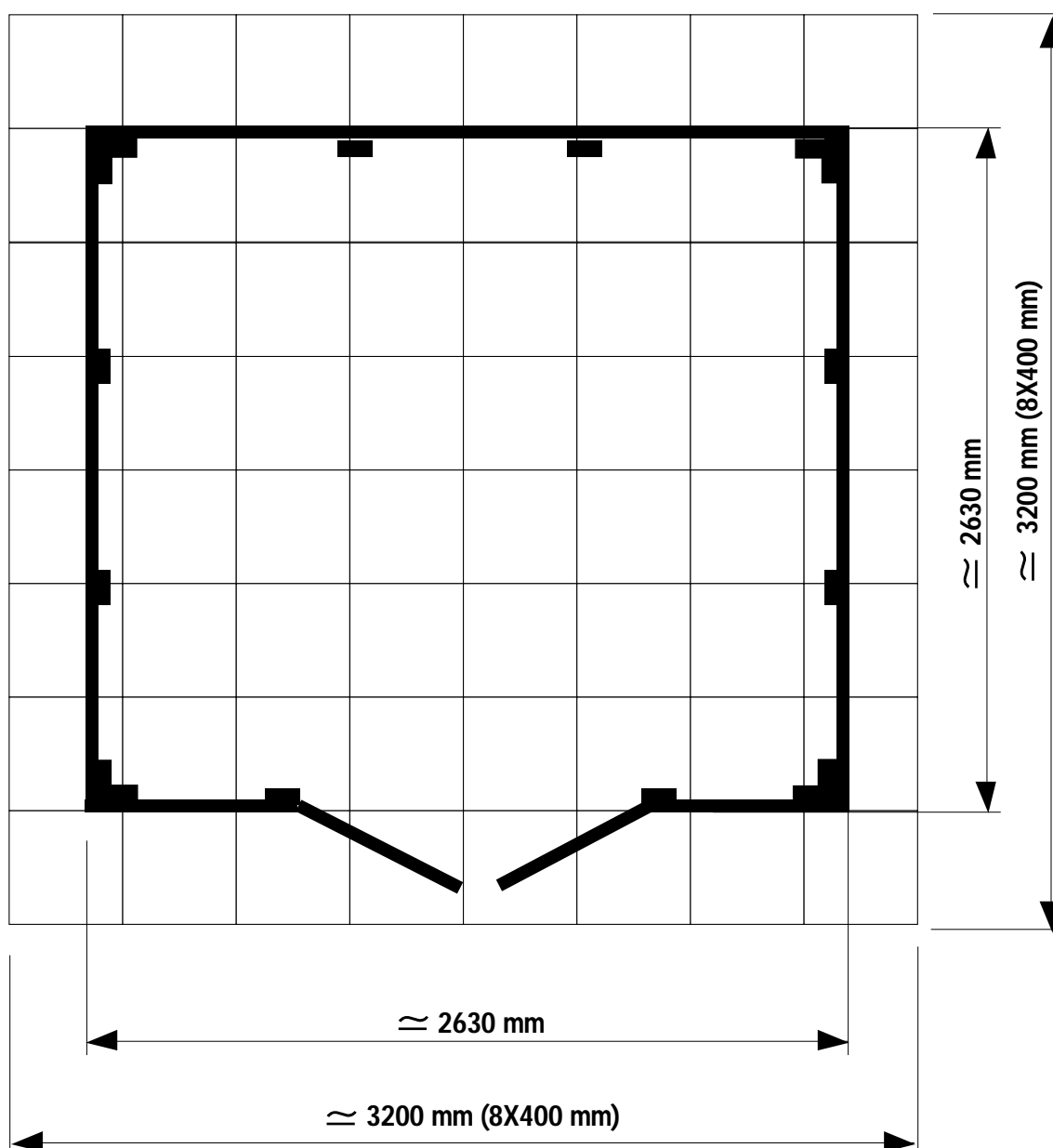
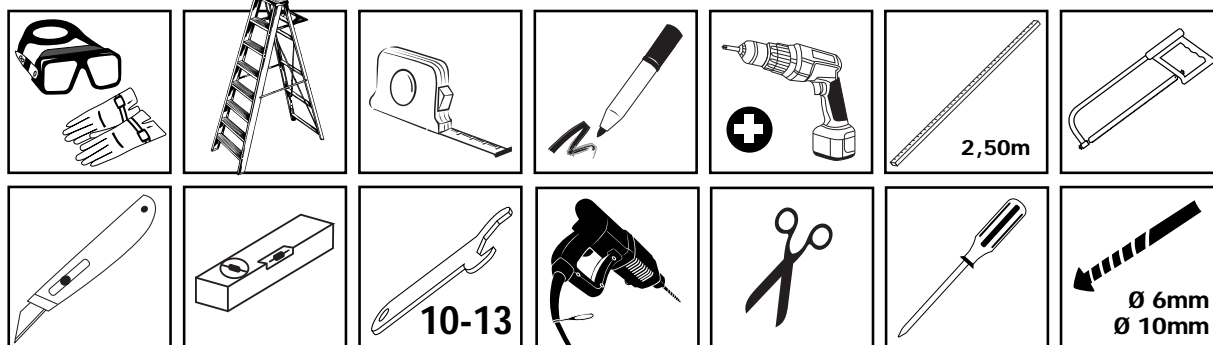



Concernant le sol :

- Bien noter que l'on peut monter un abri Gx uniquement sur un sol parfaitement plane et jamais directement sur de la terre ou sur de la pelouse.
- Le sol peut être une surface cimentée ou pavée parfaitement plane sur laquelle on pourra fixer directement l'abri Gx.
- On peut utiliser des dalles gravillonnées pour monter un abri Gx : voir descriptif suivant pour préparer le sol.

Regarding the ground:

- Please note that you can only assemble a Gx shed on completely flat ground and never directly on the ground or on a lawn. Only erect on ground that is stable and packed down.
- The ground on which the Gx shed can be directly attached to may be a cemented or paved and completely flat surface.
- You can use paving stones to assemble a Gx shed: see the diagram below about preparing the ground.

Weitere Hinweise zum Beschaffenheit des Untergrundes:

- Um ein einwandfreies Ergebnis Ihrer Montage, insbesondere in Hinsicht auf die Ausbildung der Spaltmaße der Türen, zu erzielen, ist es zwingend erforderlich, dass der Untergrund absolut waagrecht und eben ist.
- Da das Gartenhaus / Gerätehaus am Boden zu verschrauben ist, benötigen Sie einen entsprechenden Untergrund. Wir empfehlen Ihnen, als Untergrund ein Fundament aus Beton oder eine ausreichend große Fläche mit Pflastersteinen, Betonplatten, o.ä. zu erstellen.

Terreno:

- Le Home Garden Gx possono essere costruite solo su terreni perfettamente piani e mai direttamente su terra o prato. Il terreno deve essere stabilizzato e calciato.
- La superficie può essere cementata o lastricata, deve essere perfettamente piana per fissarvi facilmente la casetta Gx.
- È possibile usare lastre di laterizi. Vedere descrizione per preparare il terreno.

En lo que se refiere al suelo:

- Tenga en cuenta que solamente se puede montar un cobertizo Gx en un suelo perfectamente plano y nunca directamente en la tierra o el césped. Suelo estabilizado y apisonado.
- El suelo puede ser una superficie cementada o pavimentada, perfectamente plana, en la cual, se podrá fijar directamente el cobertizo Gx.
- Se pueden utilizar lasos gravilladas para montar un cobertizo Gx: véase la siguiente descripción para preparar el suelo.

Voor de ondergrond :

- Let op : een Gx tuinhuis kan slechts op een perfect vlakke ondergrond worden gemonteerd. Plaats het nooit rechtstreeks op de aarde of het grasperk. Een gestabiliseerde en aangestampte ondergrond is vereist.
- De ondergrond kan een gecementeerd of geplaveid oppervlak zijn, als hij maar perfect vlak is en het Gx tuinhuis er op kan worden vastgezet.
- Ook grindtegels zijn geschikt voor het opzetten van een Gx tuinhuis: zie de volgende aanwijzingen ter voorbereiding van de ondergrond.

Para o chão :

- Lembre-se que só se pode montar um abrigo Gx num chão perfeitamente plano e nunca directamente na terra ou no relvado. Chão estabilizado e compacto.
- O chão pode ser uma superfície cimentada, ou com calçada perfeitamente plana sobre a qual se pode fixar directamente o abrigo Gx.
- Podem-se utilizar lajes encascalhadas para montar um abrigo Gx : ver o descritivo seguinte para preparar o solo.

- Préparation du sol pour dalles gravillonnées :
- Enlever herbe, racines, pierres
- Ratisser et aplanir

- Preparation of the ground for paving stones:
- Remove grass, roots and stones
- Rake and level it

- Zur Erstellung einer mit Steinplatten gepflasterten Fläche empfehlen wir im Wesentlichen in folgenden Schritten vorzugehen:
- Entfernen von Gras, Wurzeln und Steinen
- ausheben des Untergrundes

- Preparare il terreno per le lastre di laterizi:
- togliere erba, radici, pietre
- Rastrellare e spianare

- Preparación del suelo para losas gravilladas:
- Retirar la hierba, raíces y piedras
- Rastrillar y nivelar

- Voorbereiding van de ondergrond voor grindtegels :
- Verwijder gras, wortels en stenen
- Harken en effenen

- Preparação do solo para lajes encascalhadas:
- Remover as ervas, raízes, pedras
- Limpar com ancinho e aplanar

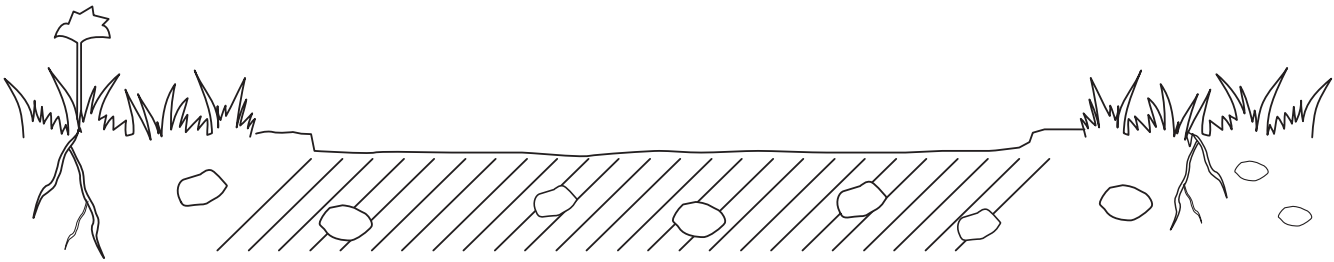

- Tasser le sol

- Pack down the ground

- einbringen und Verteilen von Sand

- Pressare il suolo

- Apisonar el suelo

- De grond aandrukken

- Comprimir o chão

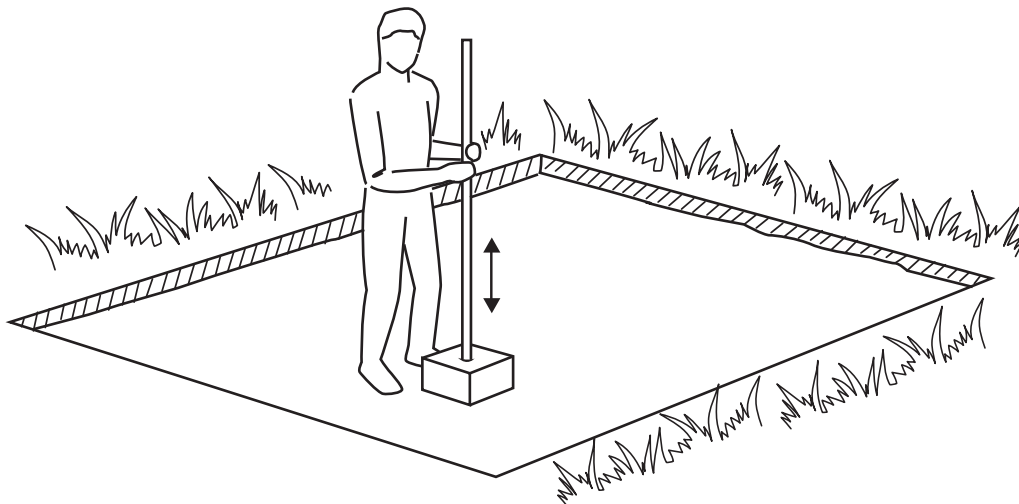

F

- Mettre du sable
- Egaliser
- Tasser et mettre de niveau

GB

- Put down the sand
- Level it
- Pack it down and level it

D

- lot-, flucht- und waagerechtes Einbringen der Pflastersteine / Platten

I

- Mettere la sabbia
- Rendere piano
- Pressare e livellare

SP

- Poner arena
- Igualar
- Apisonar y nivelar

NL

- Zand aanbrenen
- Egaliseren
- Aandrukken en nivelleren

P

- Pôr areia
- Nivelar
- Comprimir e voltar a nivelar

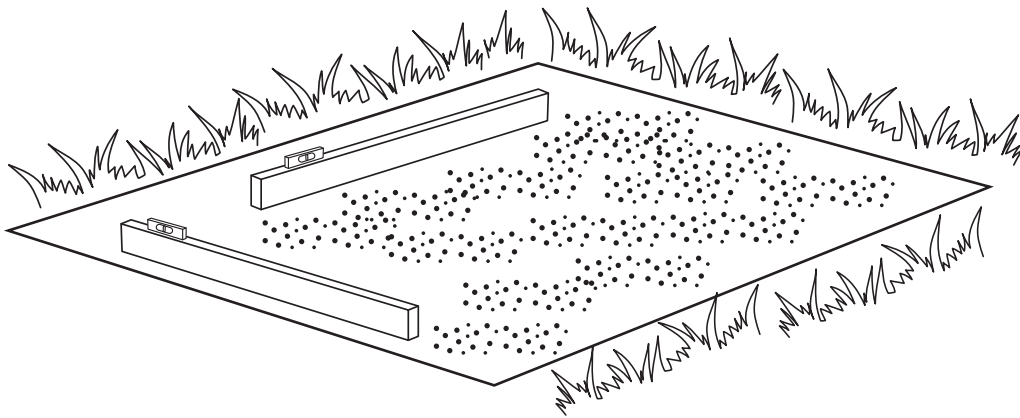
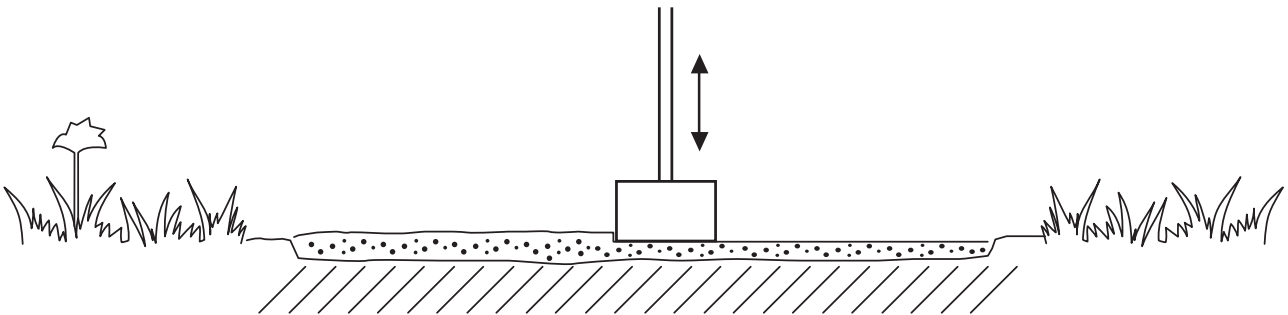

- Poser les dalles et tasser
- Mettre de niveau

- Lay the paving stones and pack them down

Wenden Sie sich, wenn Sie Hilfe bei der Erstellung des Untergrundes benötigen, gegebenenfalls an einen Garten- und Landschaftsbauer

- Posare le lastre e pressare
- Livellare

- Colocar las losas y apisonar
- Nivelar

- De tegels plaatsen en aandrukken
- Nivelleren

- Colocar las lajas e comprimir
- Nivelar

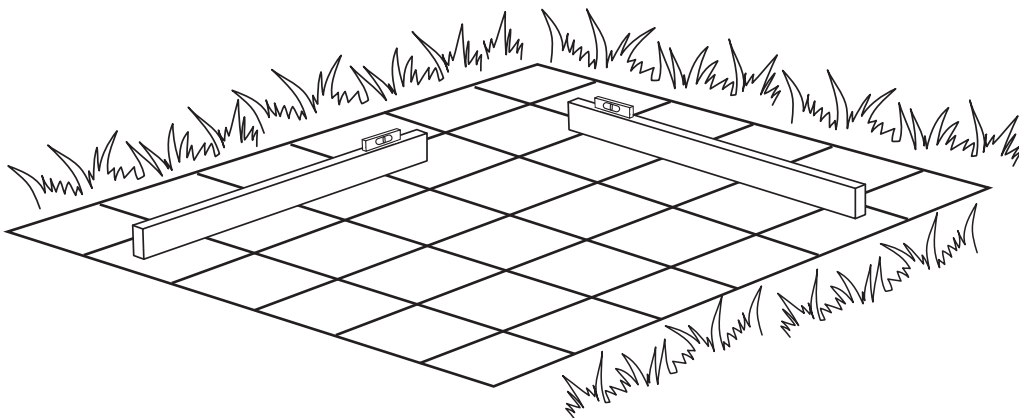
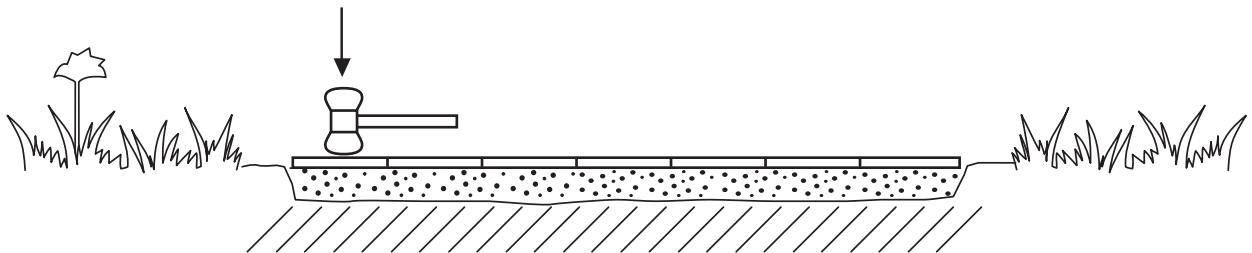

1.1

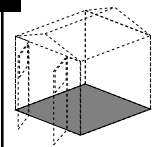

M02A (x4)
F4B6 (x2)
F4B4 (x2)
V13-SH03 (x8)
A02 (x2)

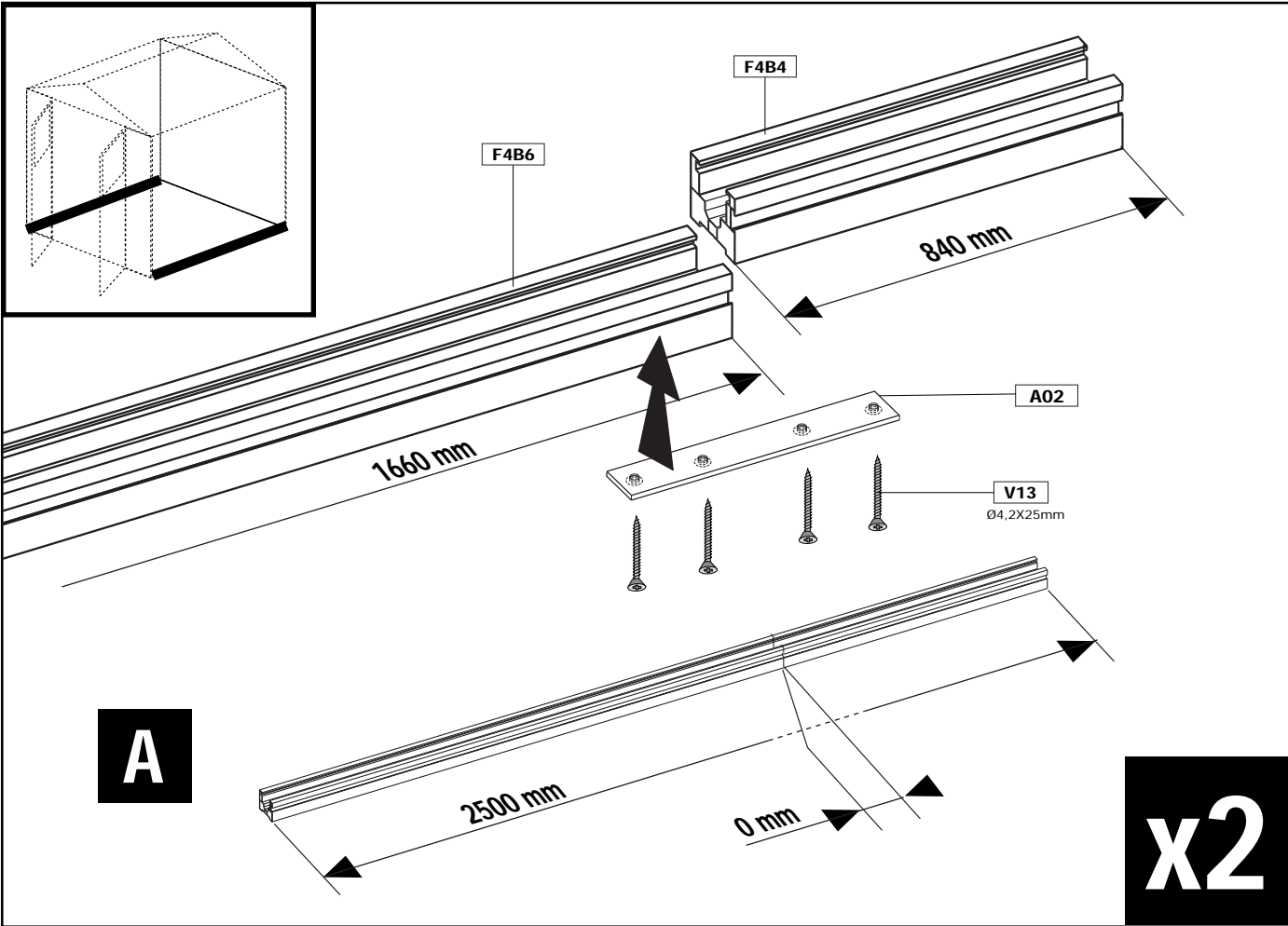
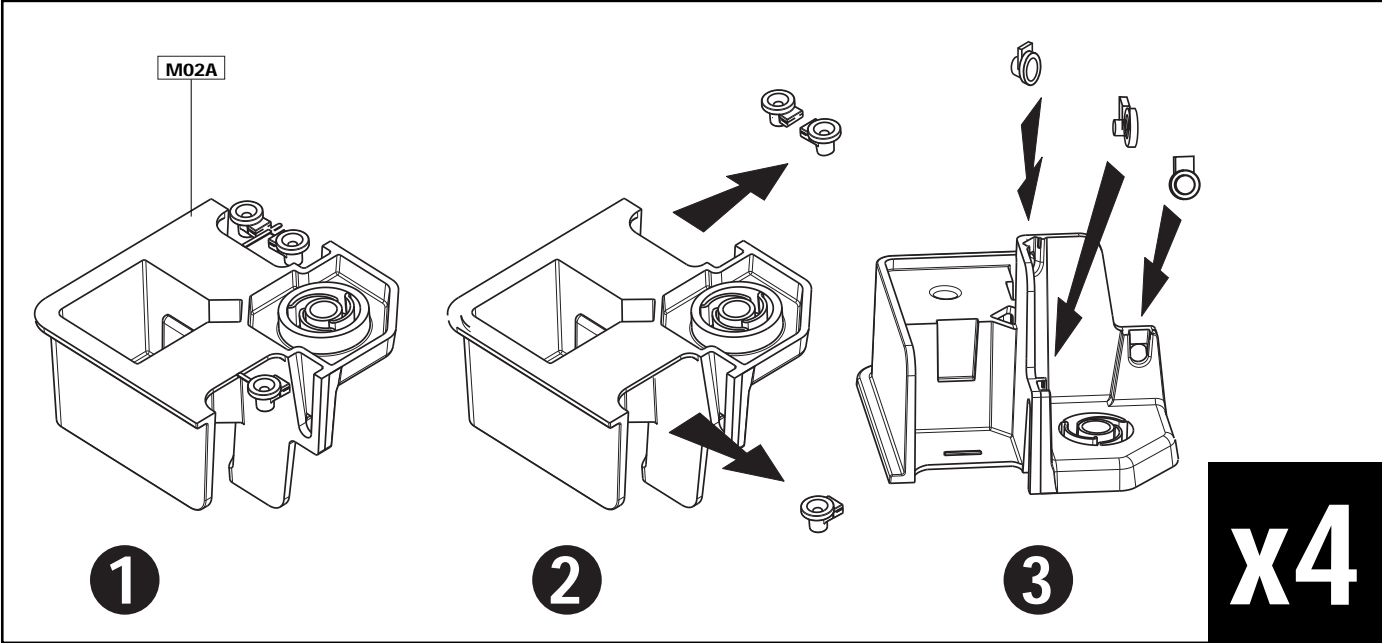
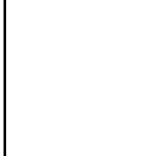
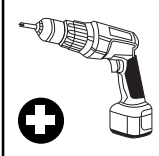

1.2

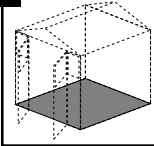

F4B6 (x1)
F4B4 (x1)
A02 (x1)
V13- SH03 (x4)

F4F4 (x2)
A01B (x1)
V13- SH03 (x4)

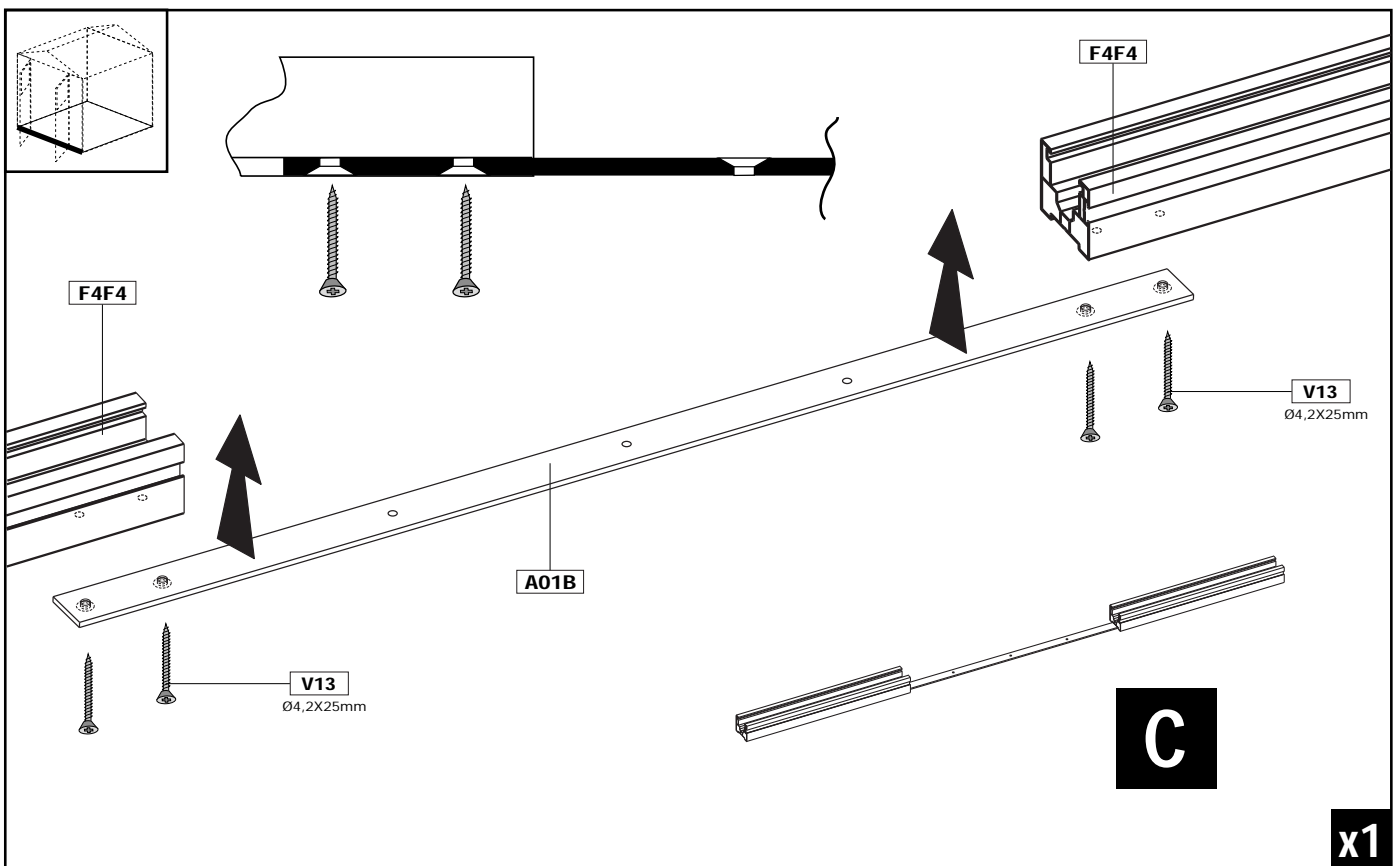
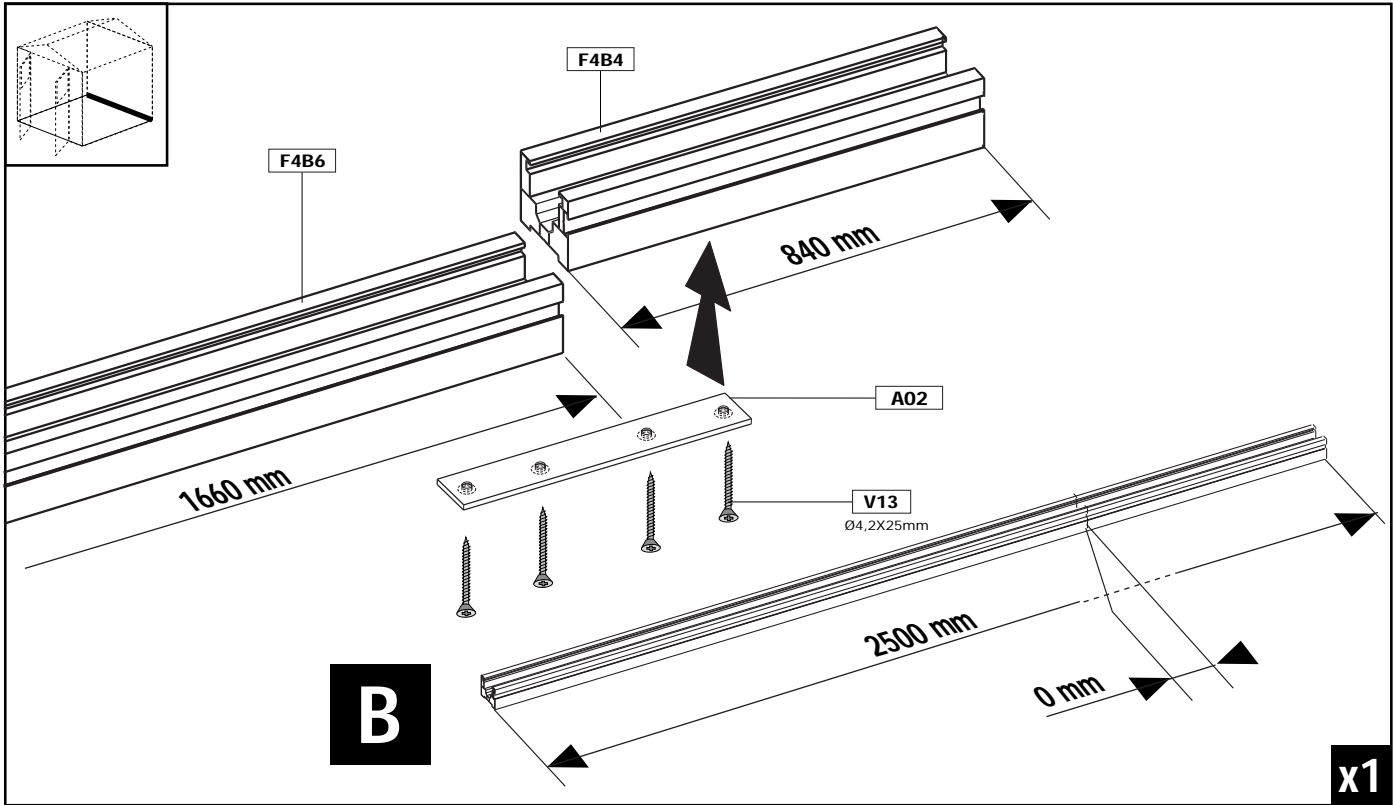
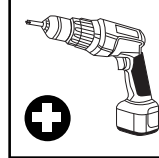
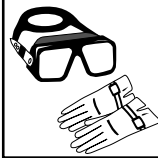

1.3

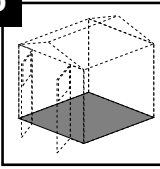

- M02A (x1)
- V04- SH01 (x1)
- V08- SH01 (x1)
- V23- SH01 (x1)

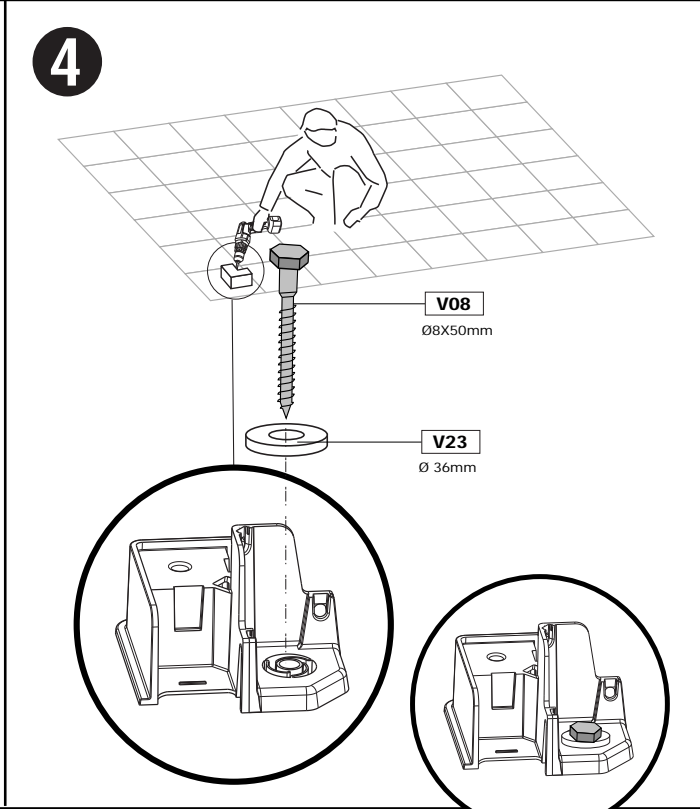
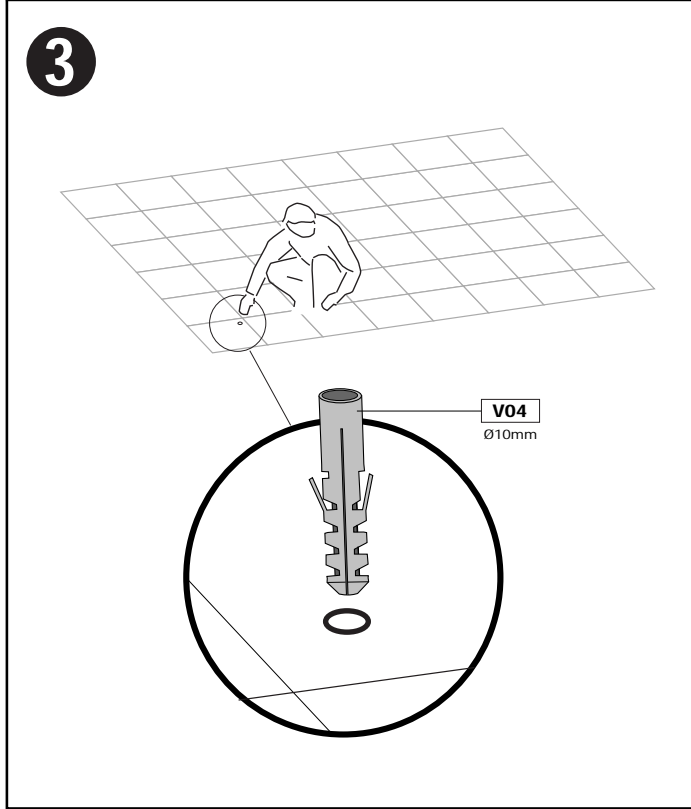
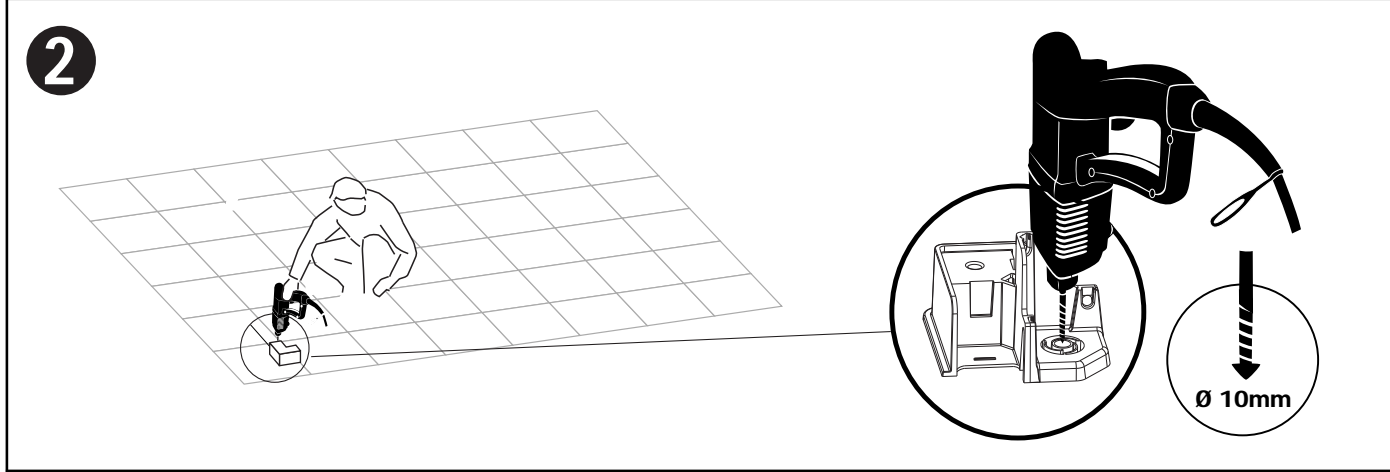
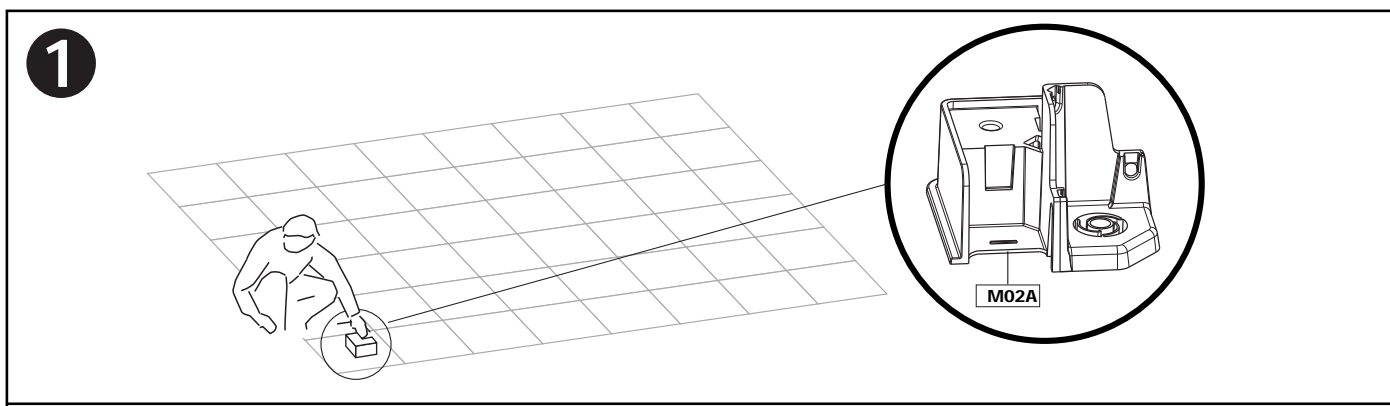
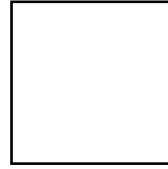
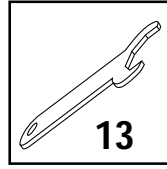
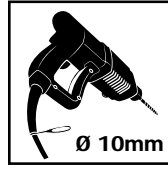
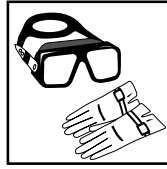

1.4

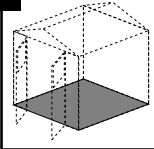

- A (x1)
- A03 (x6)
- V03- SH09 (x6)
- V16- SH05 (x6)
- V22- SH07 (x6)

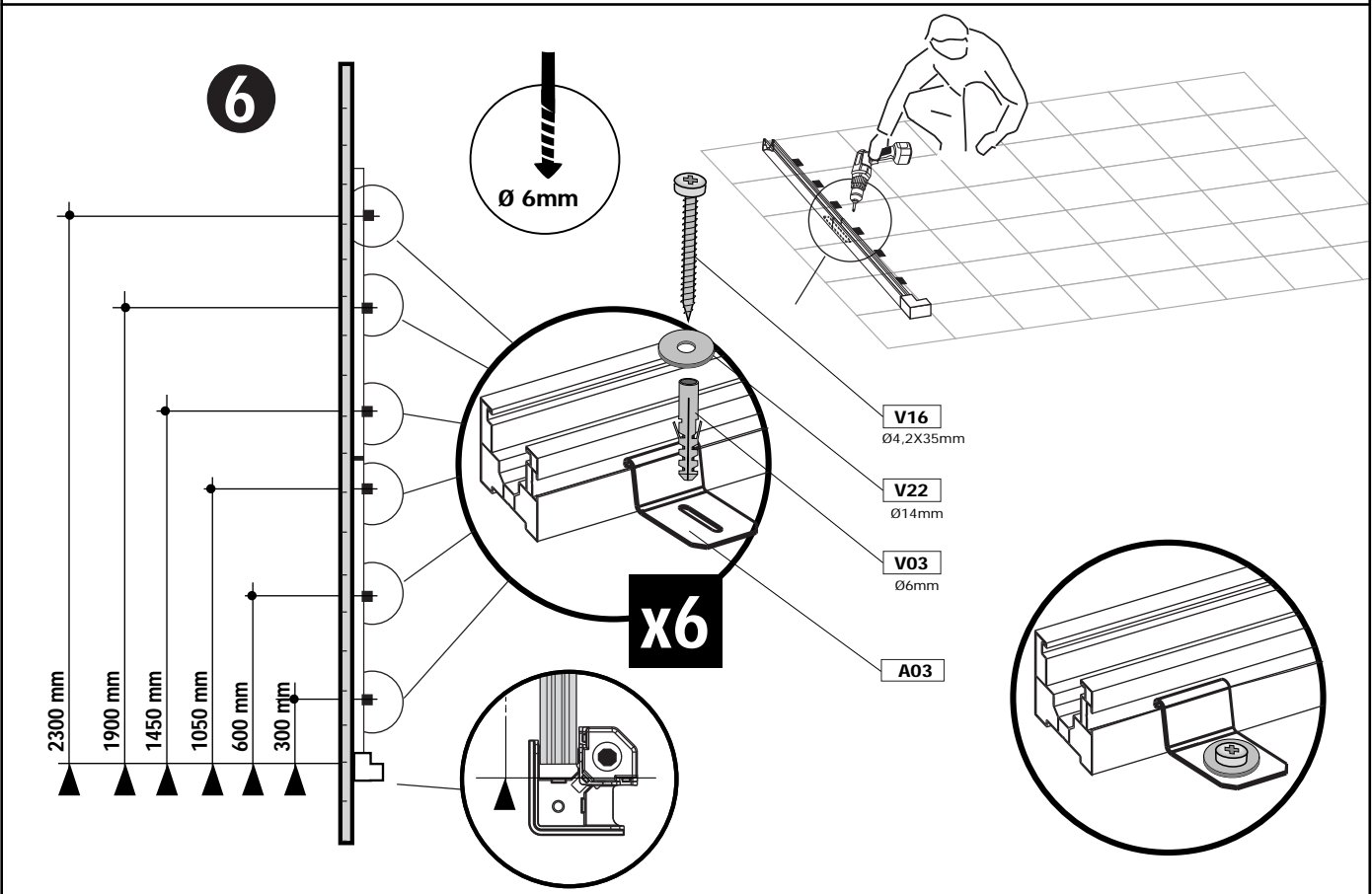
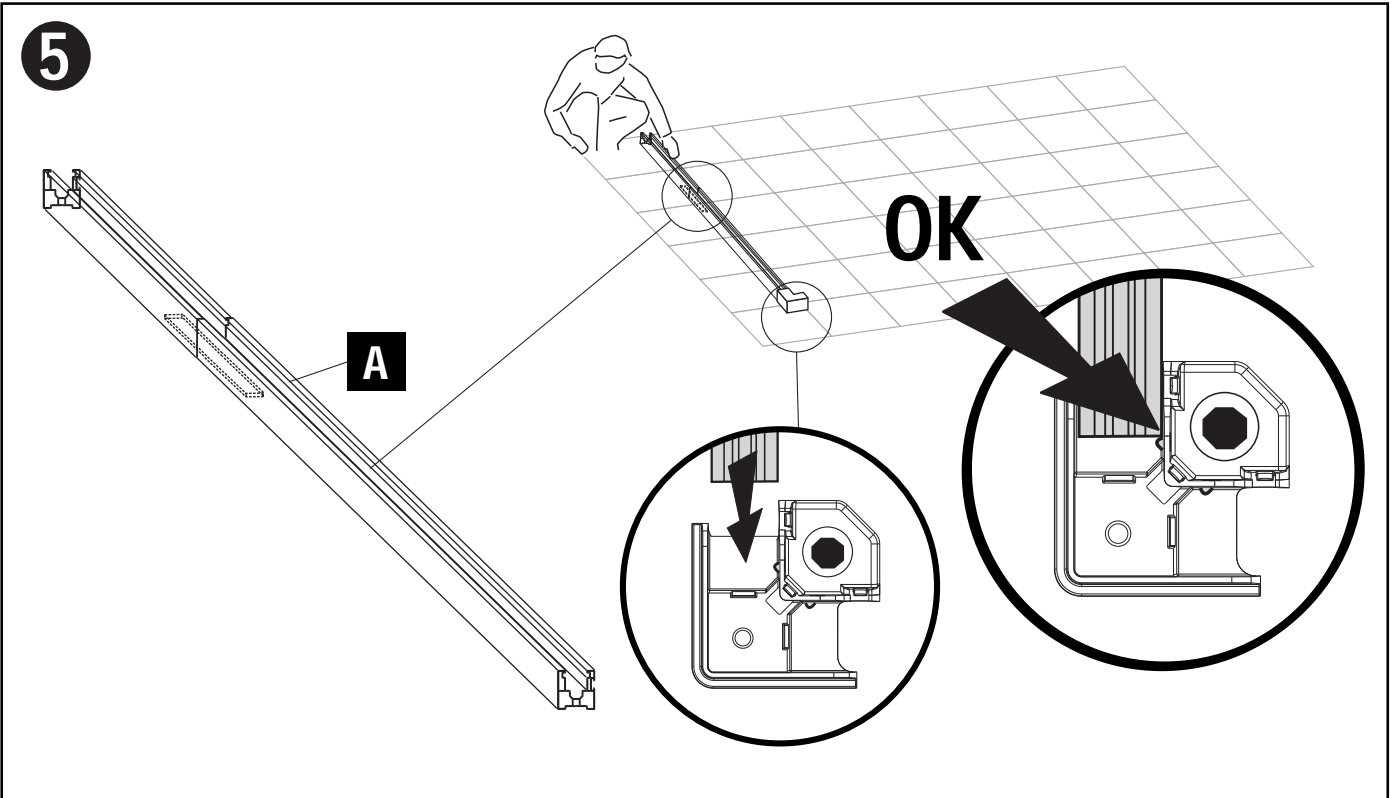
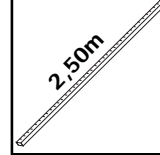
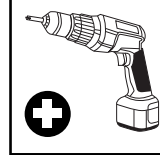
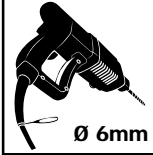

1.5

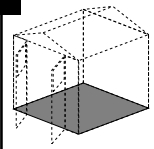

C (x1)
A03 (x2)
V03- SH09 (x2)
V16- SH08 (x2)
V22- SH07 (x2)

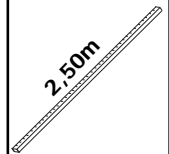
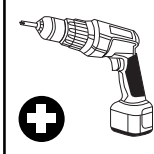

7

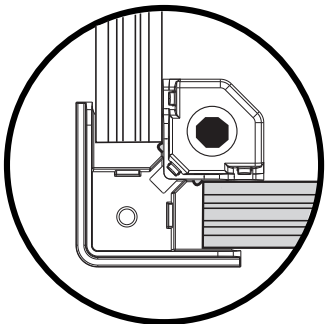
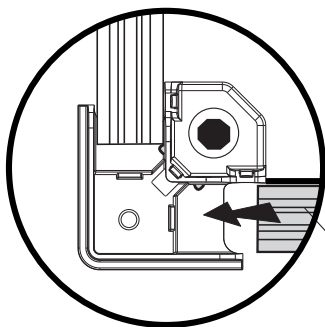

90°?

1m

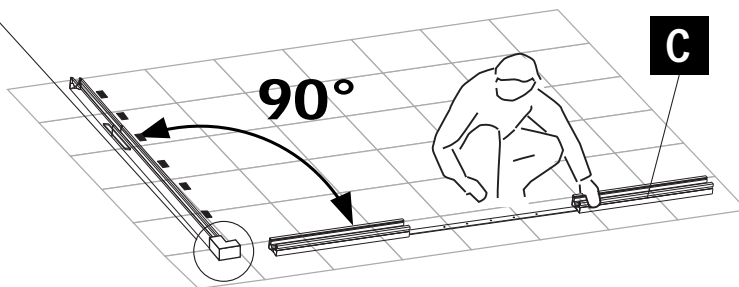
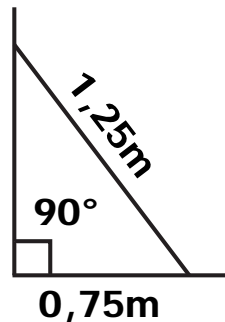

8

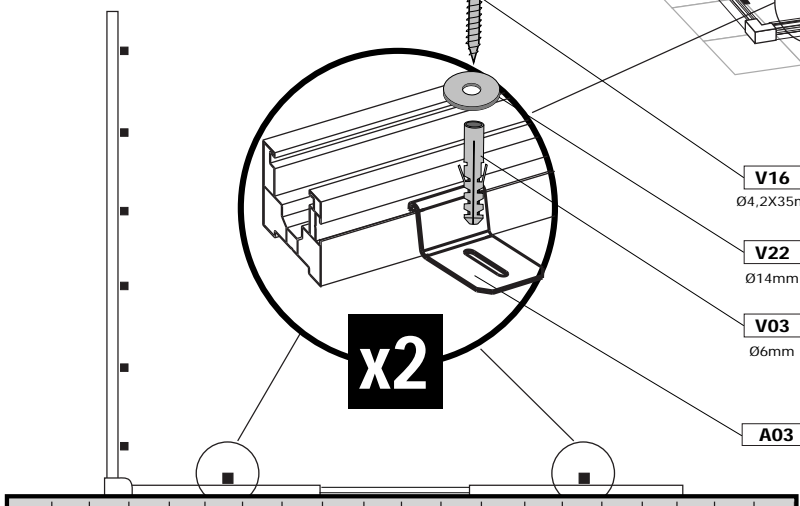
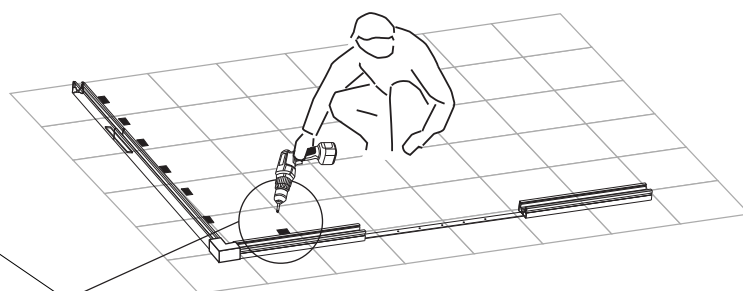
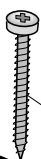
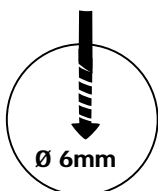

x2

V16
Ø4,2X35mm

V22
Ø14mm

V03
Ø6mm

A03

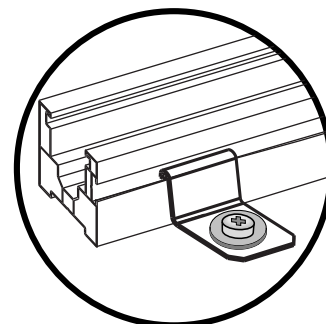

1.6

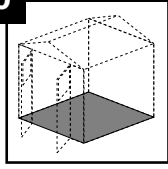

M02A (x1)
B (x1)

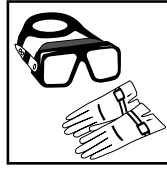

9

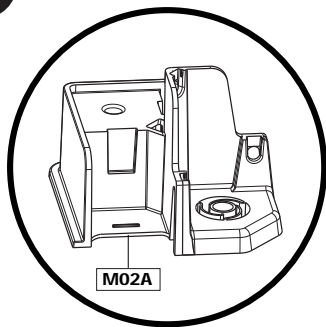

M02A

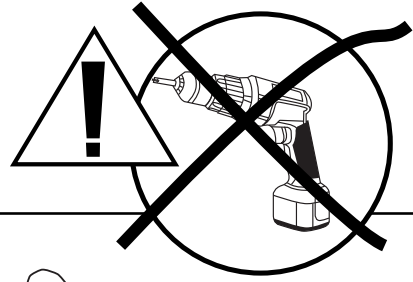
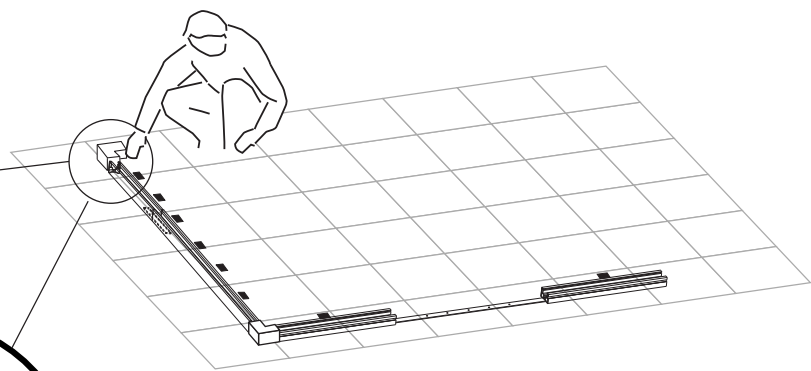
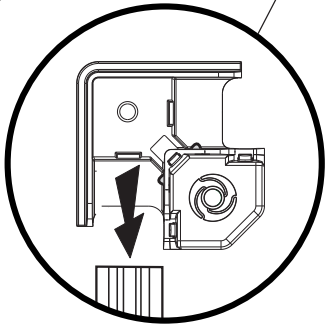

NE PAS FIXER AU SOL • DO NOT SECURE IT
NICHT AM BODEN BEVESTIGEN • NO FIJAR AL SUELO
NON FISSARE AL SUOLO • NIET BEVESTIGEN AAN DE BODEM
NÃO FIXAR AO SOLO

10

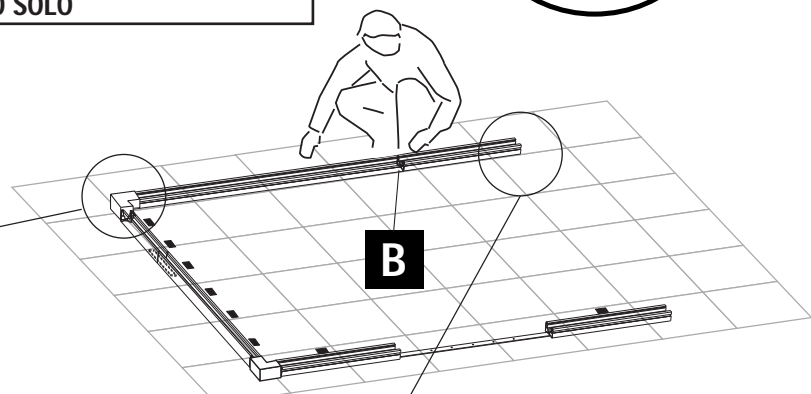
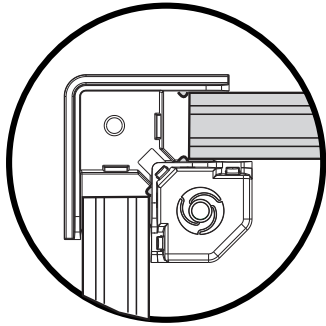
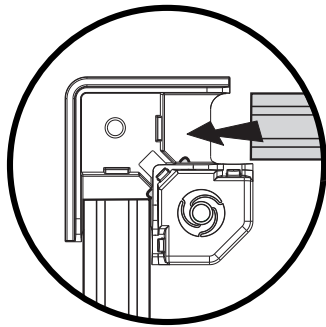

B

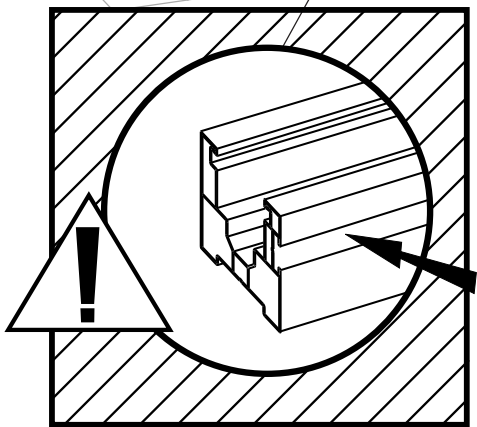

Intérieur
Inside

1.7

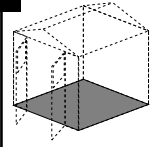

M02A(x2)
A(x1)



11

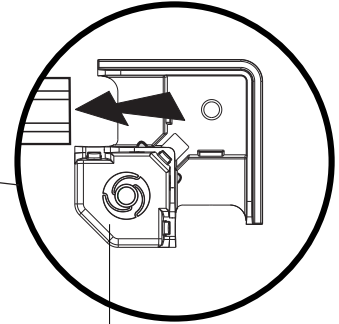
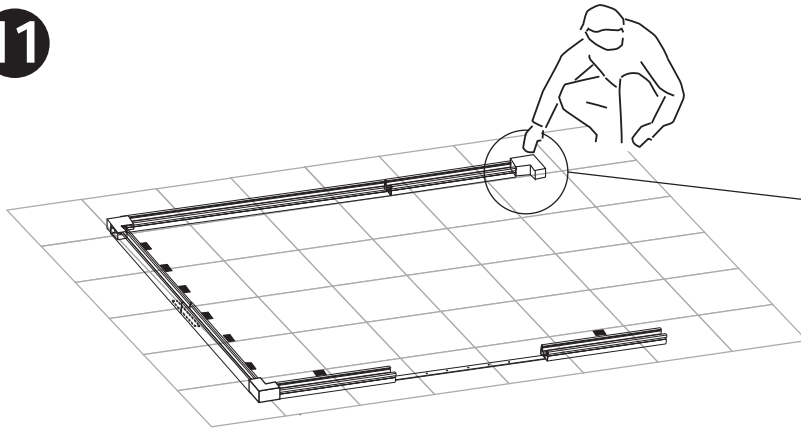

M02A

NE PAS FIXER AU SOL • DO NOT SECURE IT
NIGHT AM BODEN BEFESTIGEN • NO FIJAR AL SUELO
NON FISSARE AL SUOLO • NIET BEVESTIGEN AAN DE BODEM
NÃO FIXAR AO SOLO

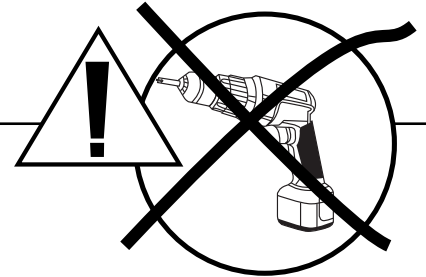

12

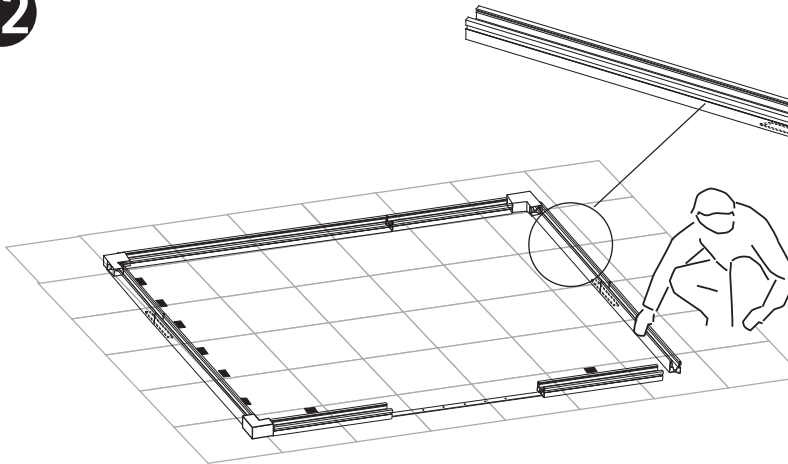

A

Intérieur
Inside

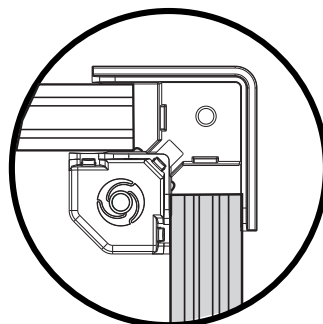
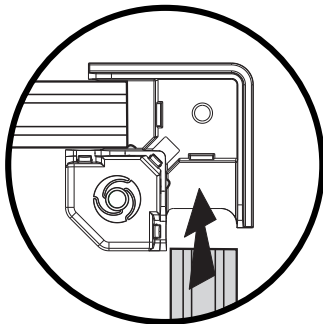
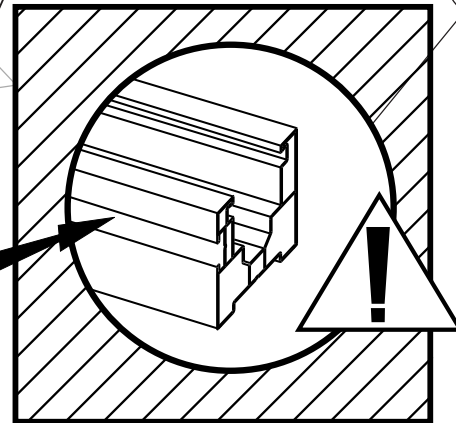

13

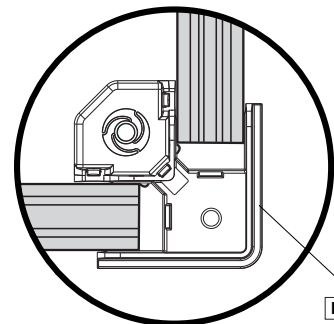

M02A

2.1

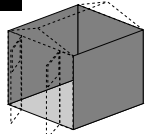

F2A (x1)

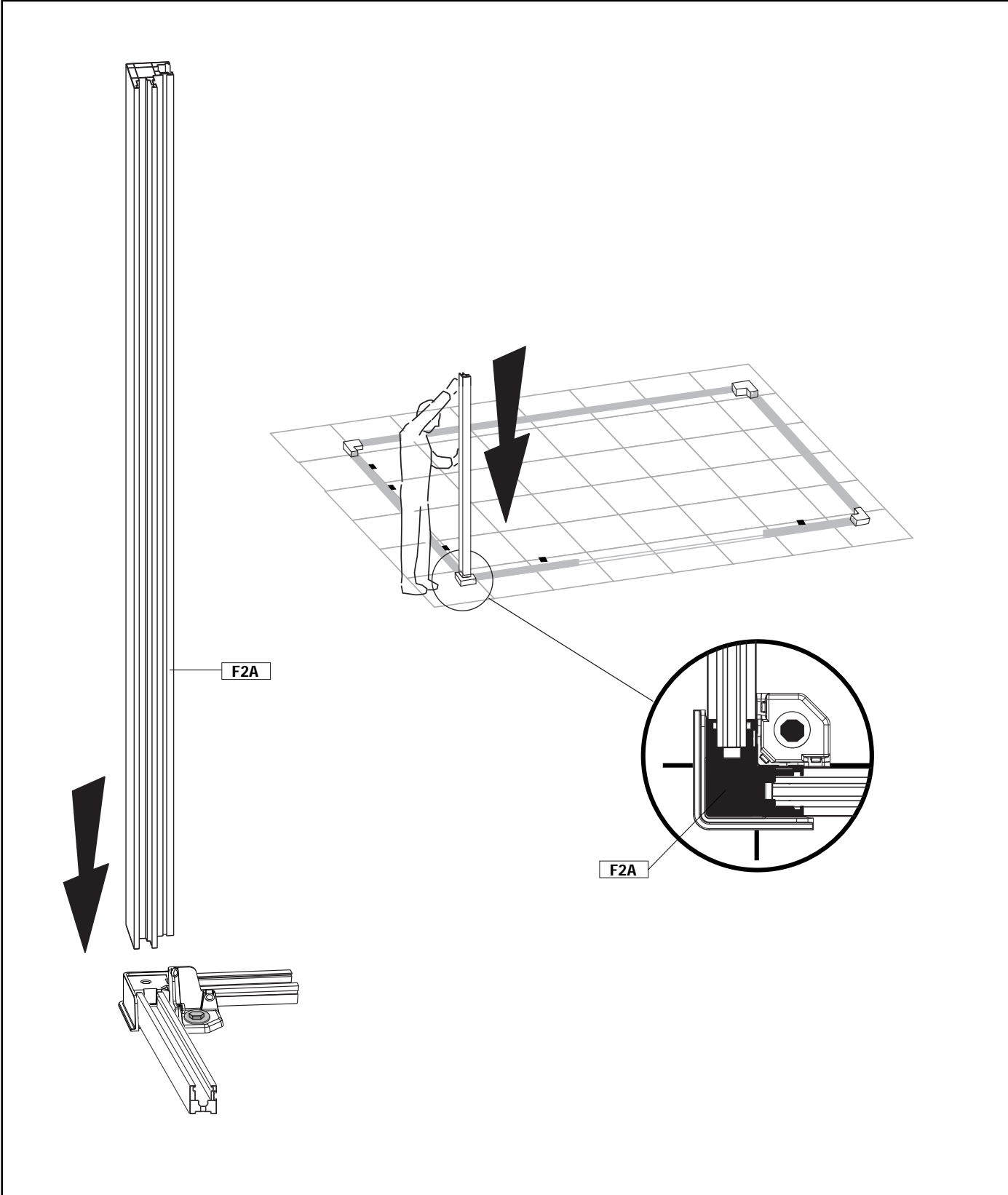
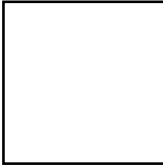

2.2

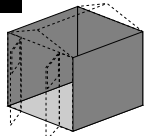

F1H2 (x1)

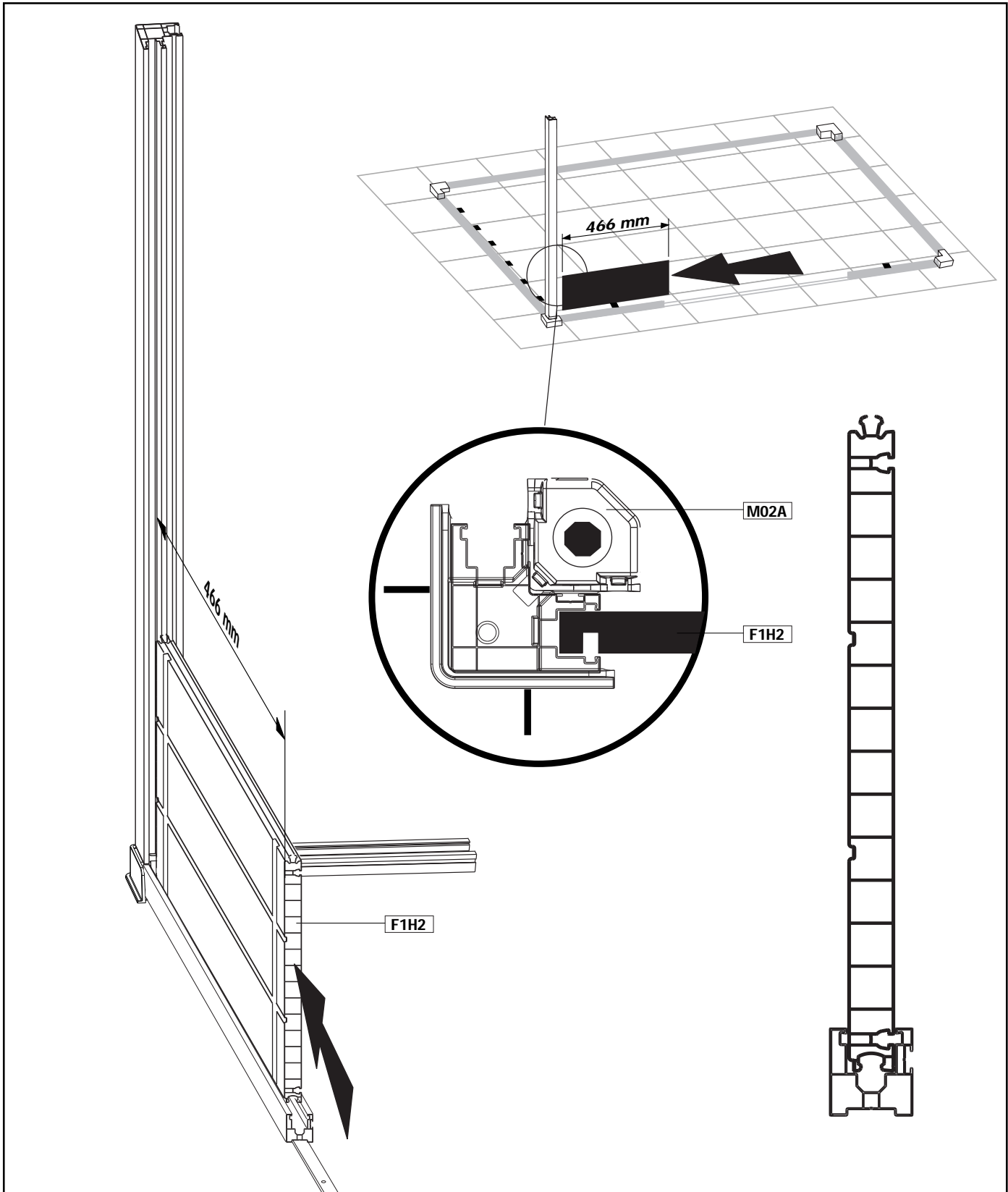

2.3

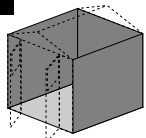

F10A (x1)

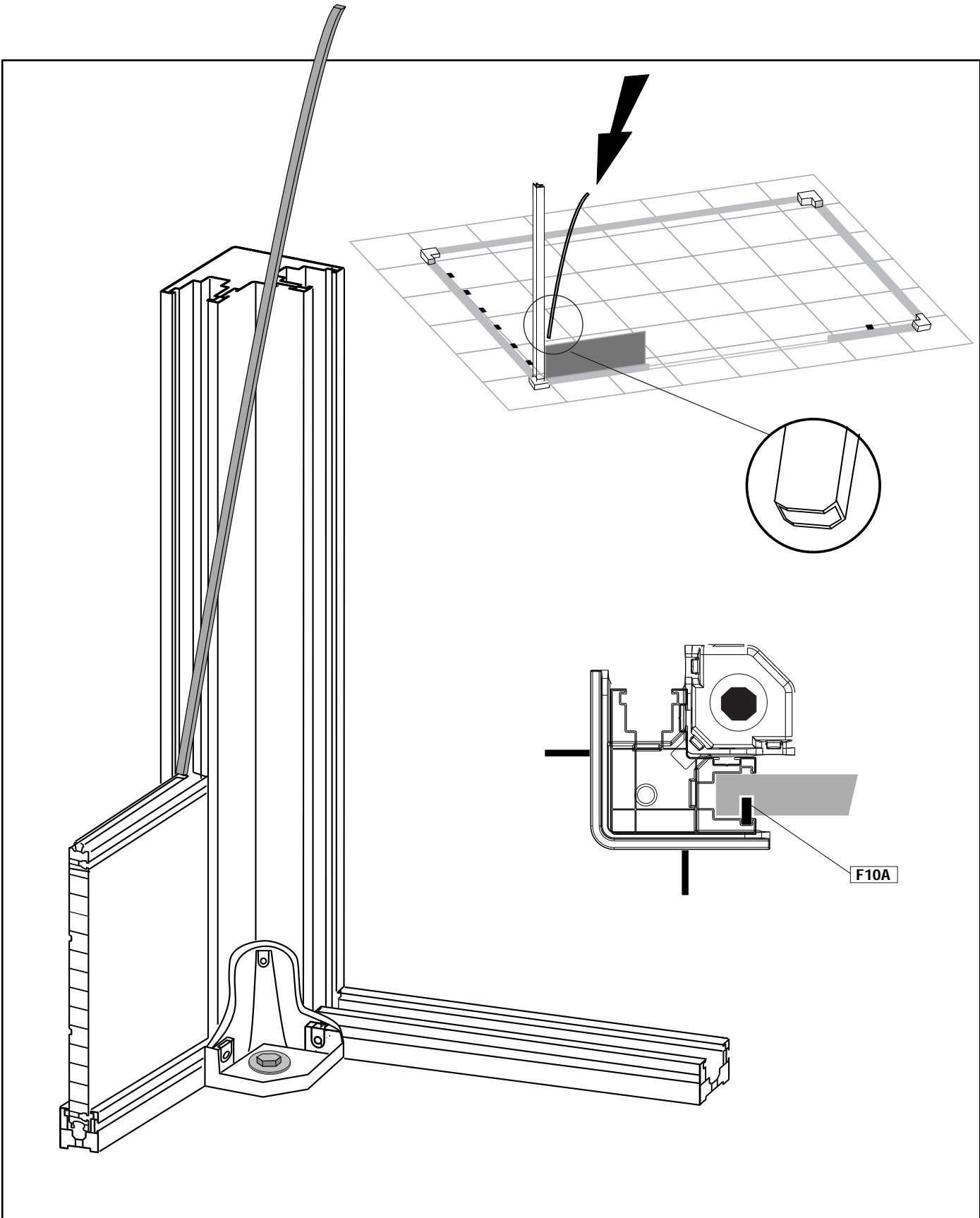
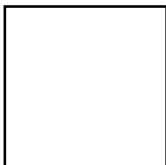
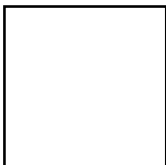
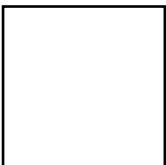

H12-0610-20

H7-1312-21

2.4

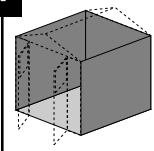

F1H1 (x1)

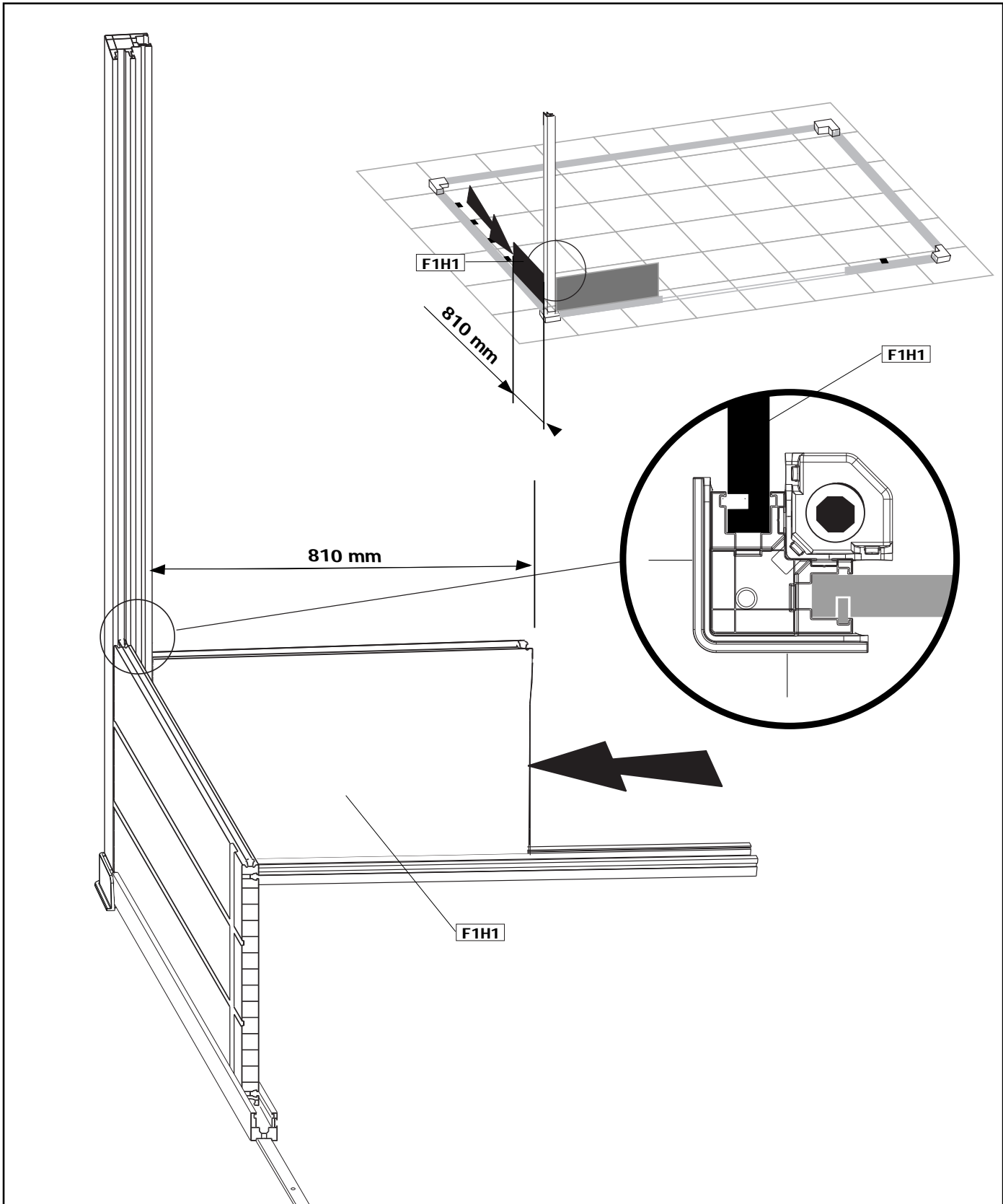
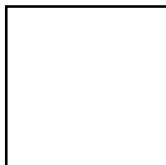
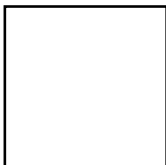
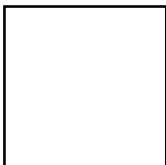
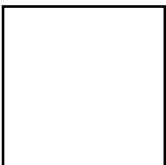

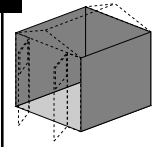

2.5

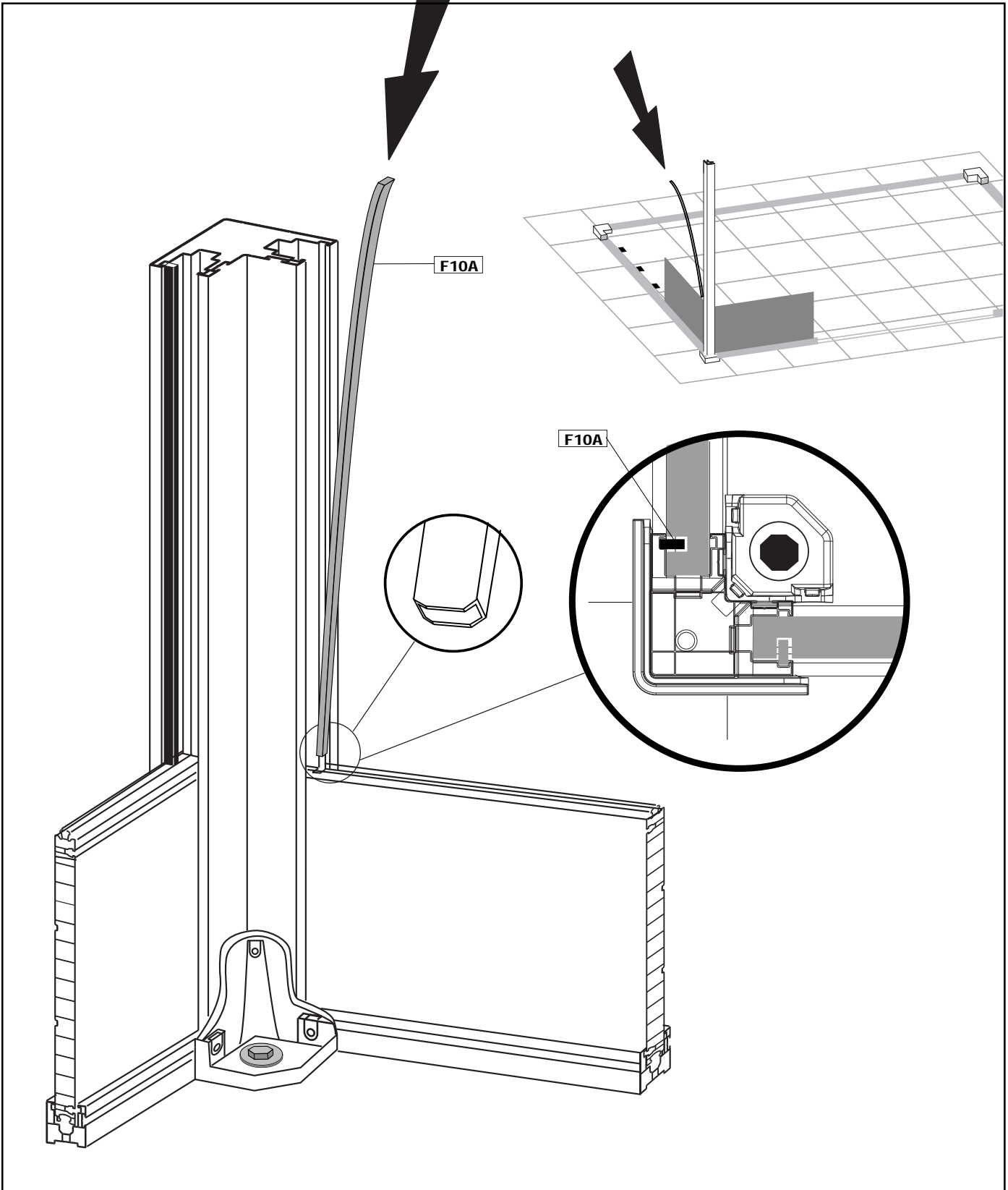

F10A (x1)

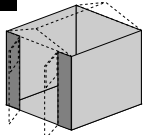

2.6

	<p>EM1 (x1) F10A (x1)</p>					
---	-------------------------------	---	--	--	--	--

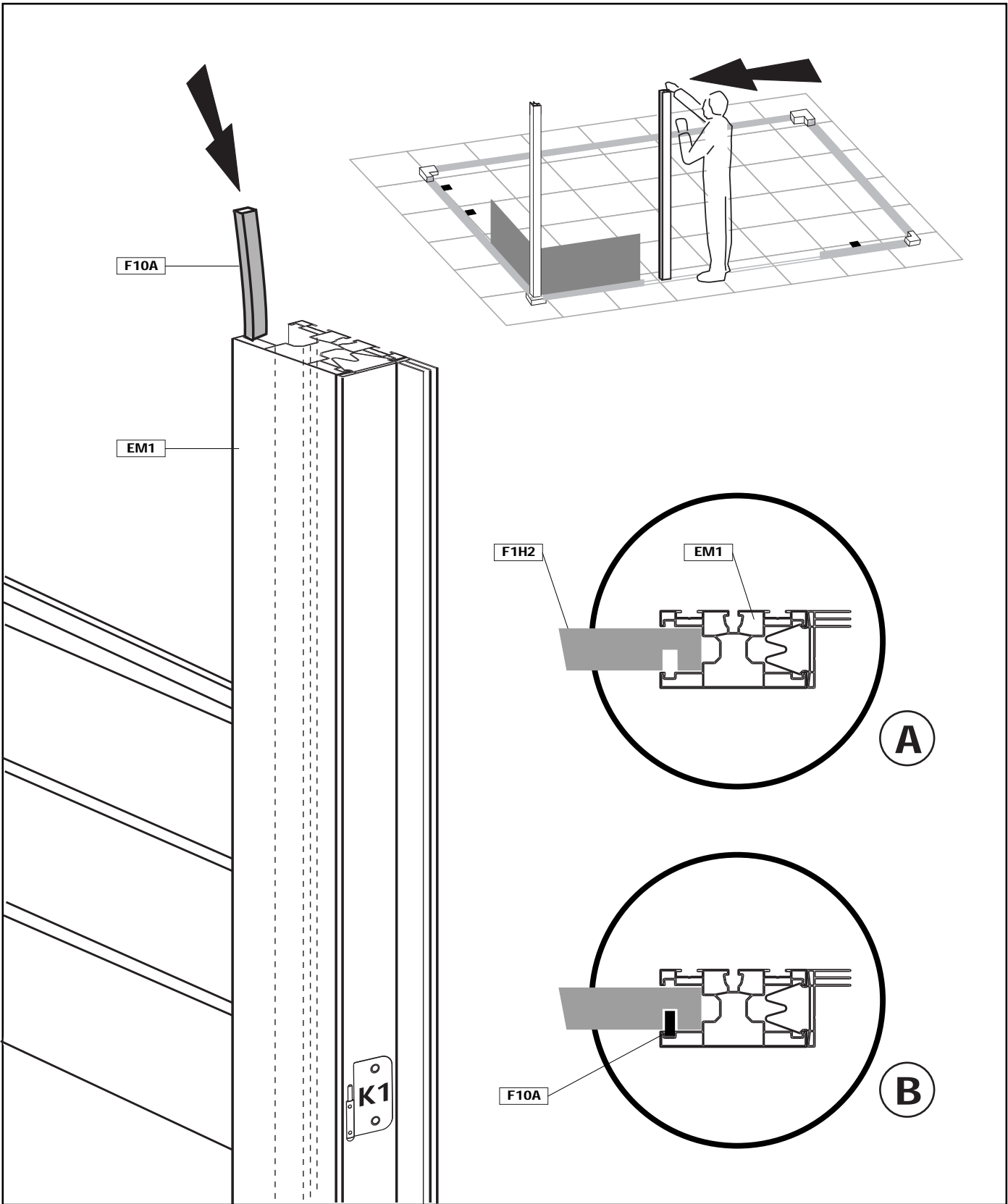

2.7

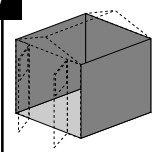

F1H2 (x1)

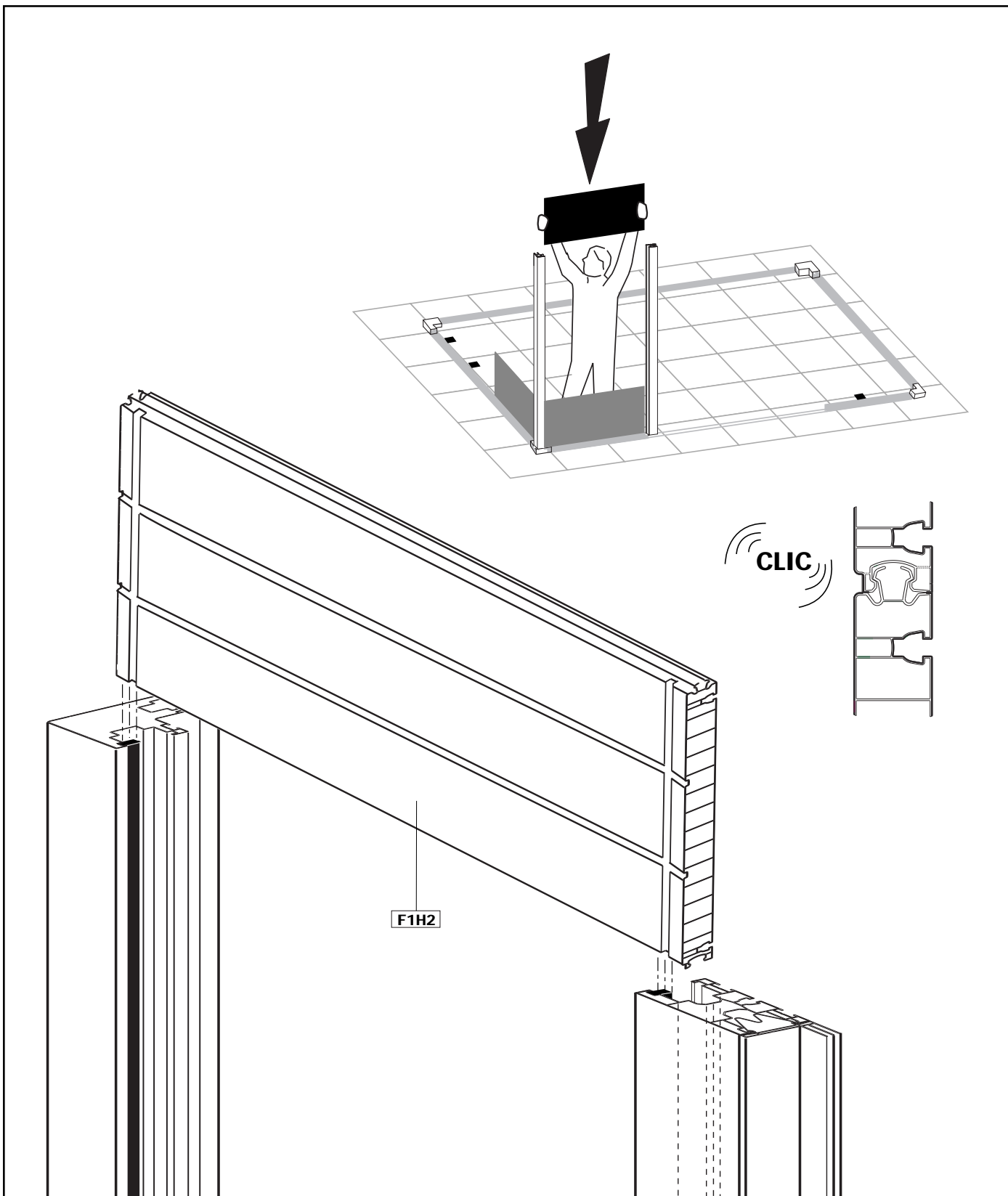

2.8

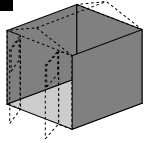

F1H2 (x3)
F3A (x1)
F10A (x1)

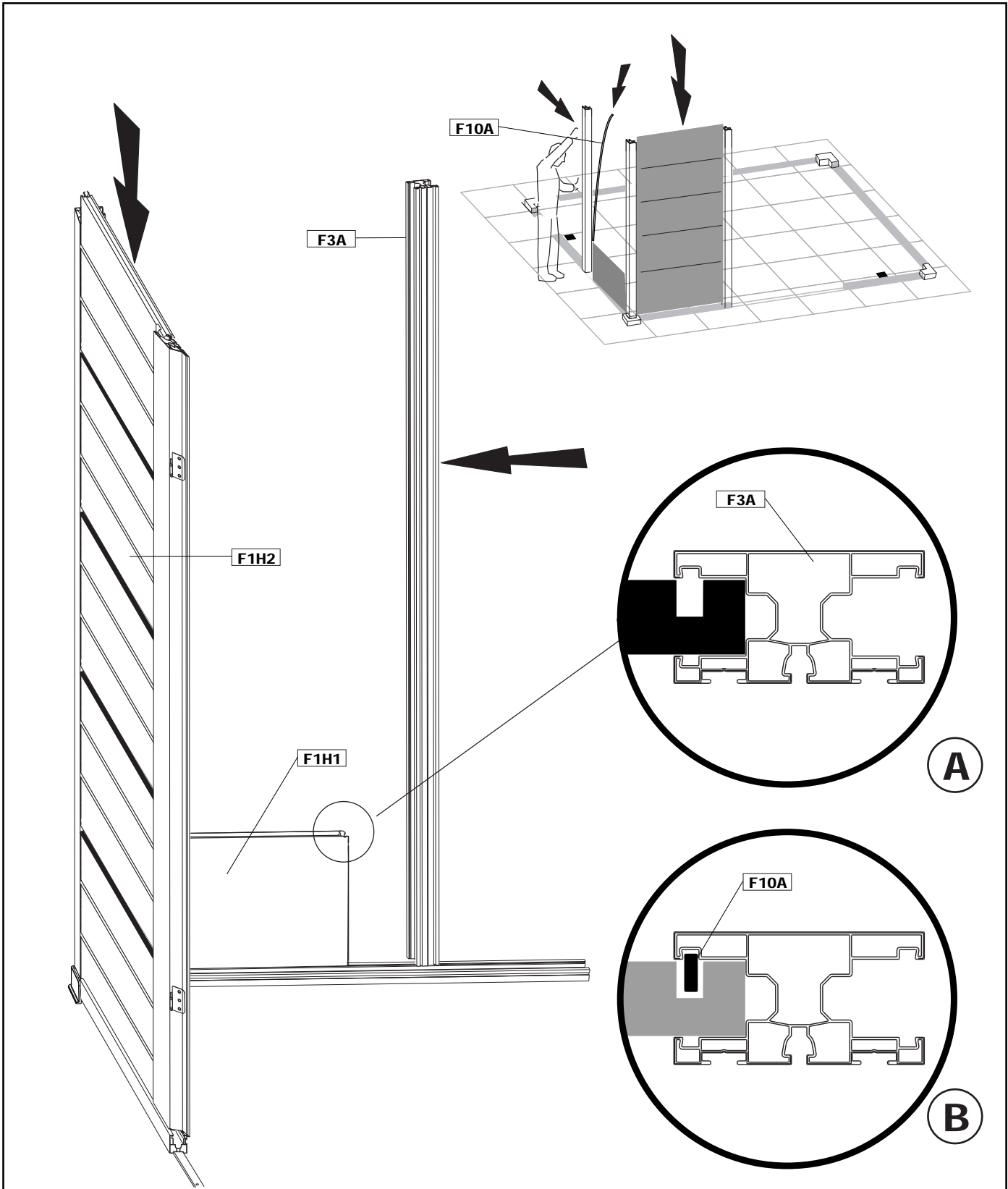

2.9

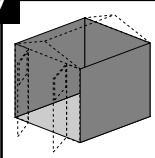

F1H1 (x4)

F10A (x2)

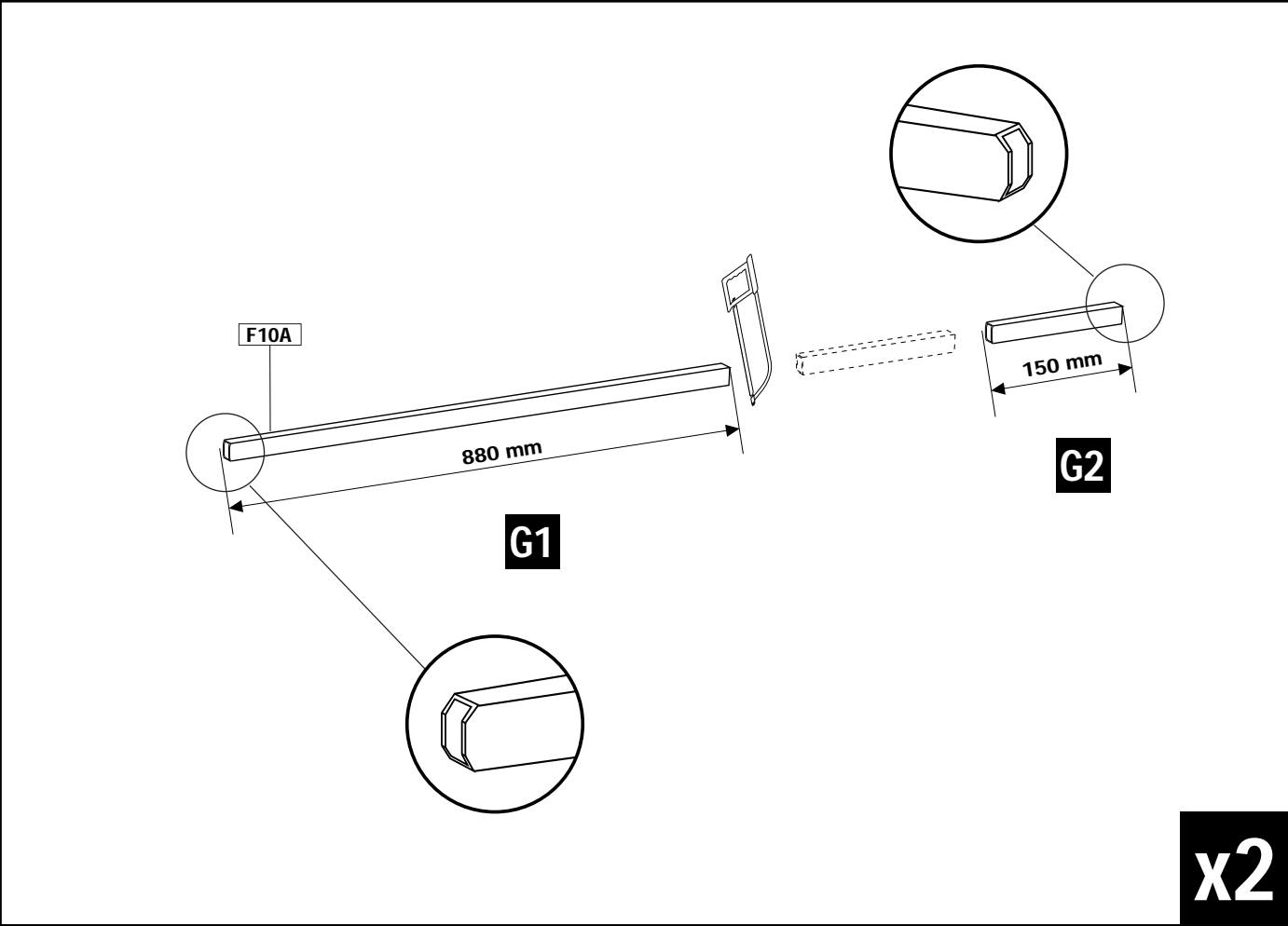
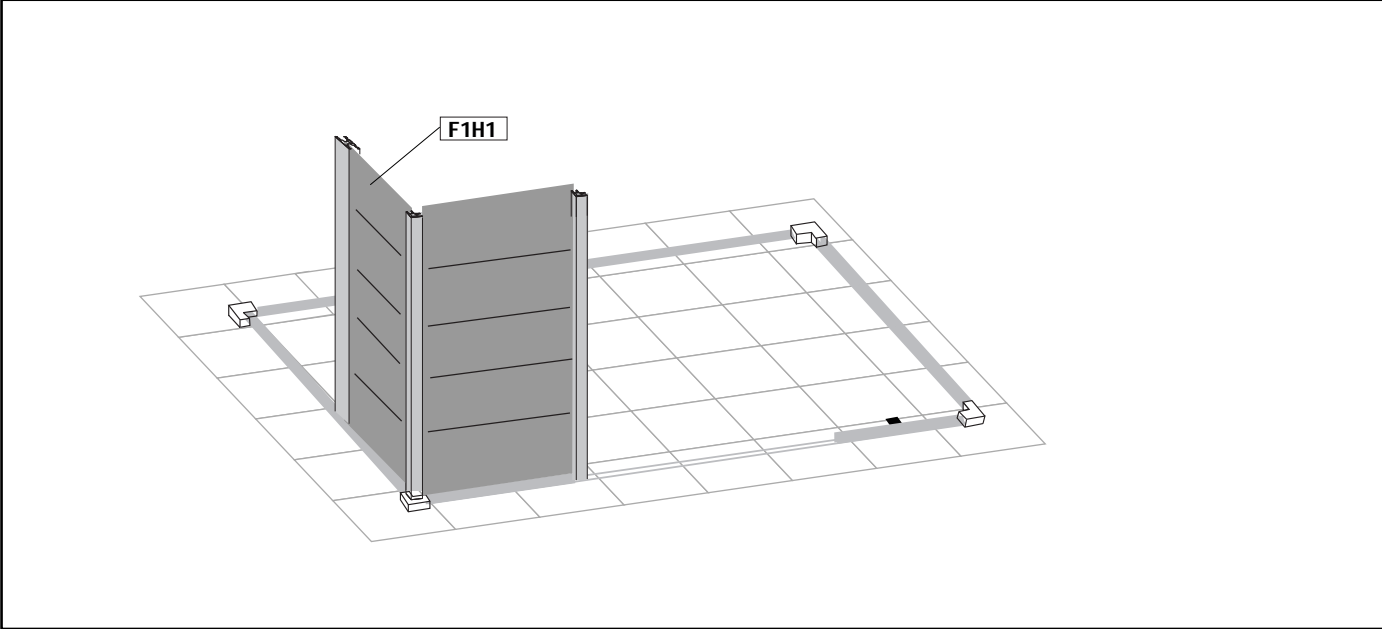
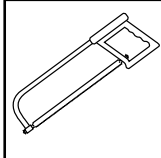
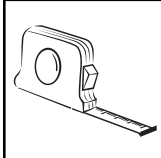

2.10

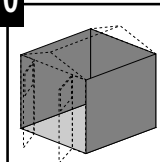

G1 (x2)
F1H1 (x2)
F1D2 (x1)

EF2 (x1)

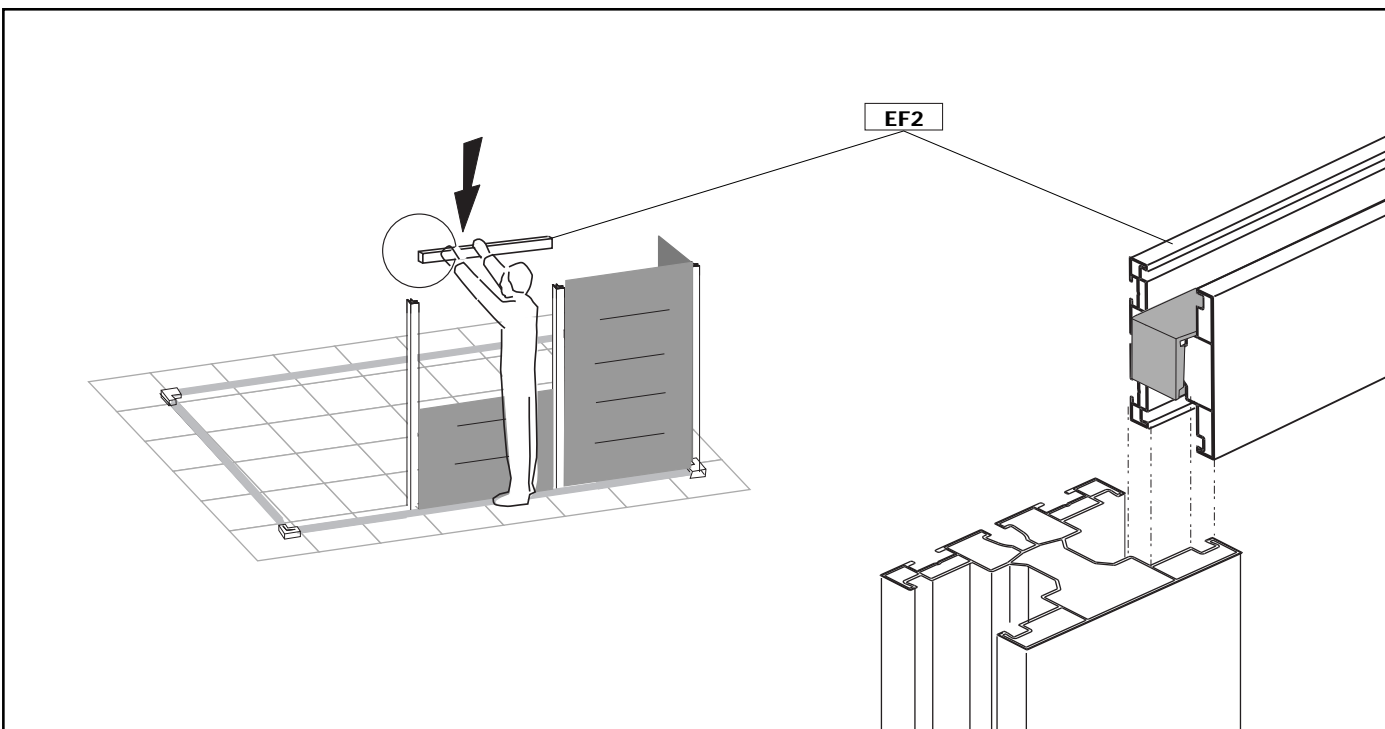
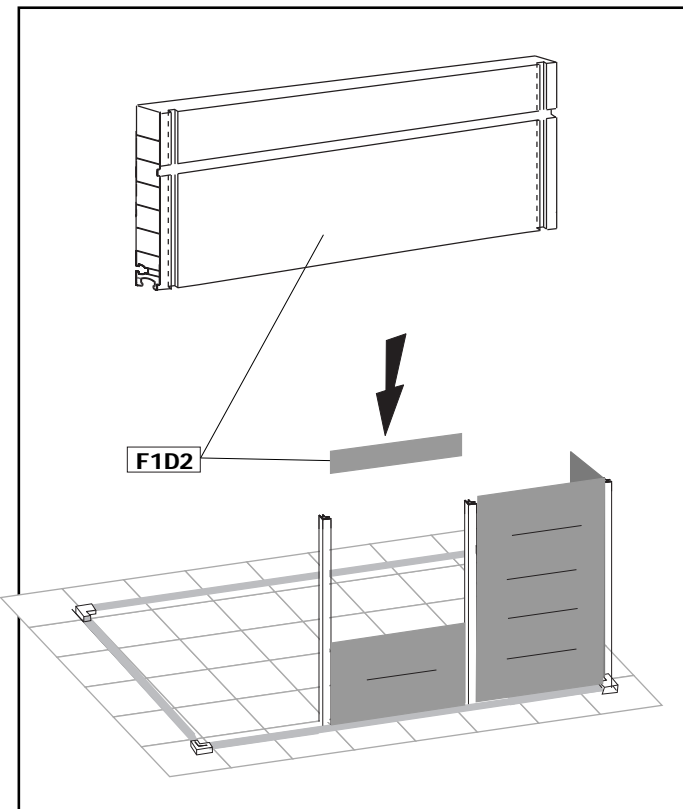
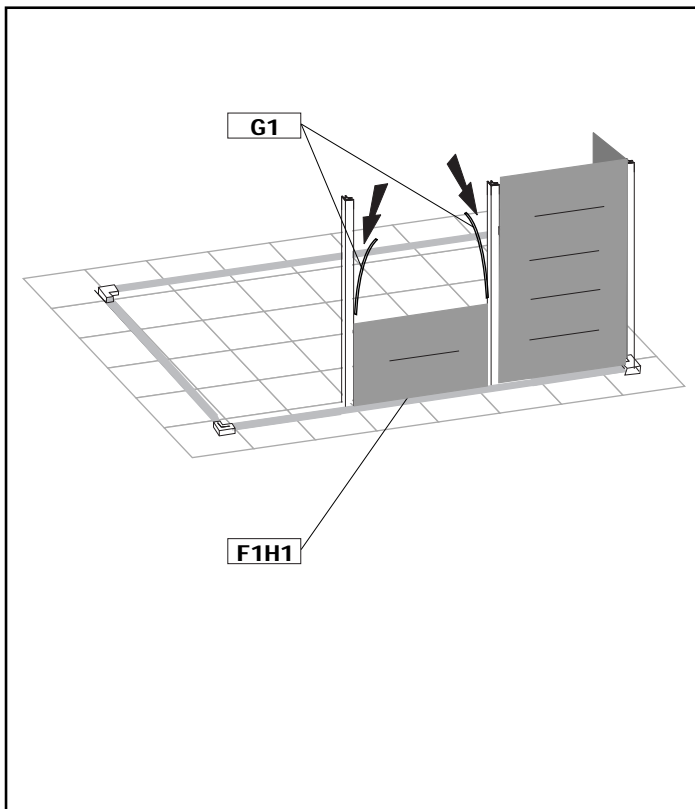

2.11

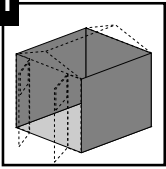

F6E2 (x1)
F6D2 (x2)

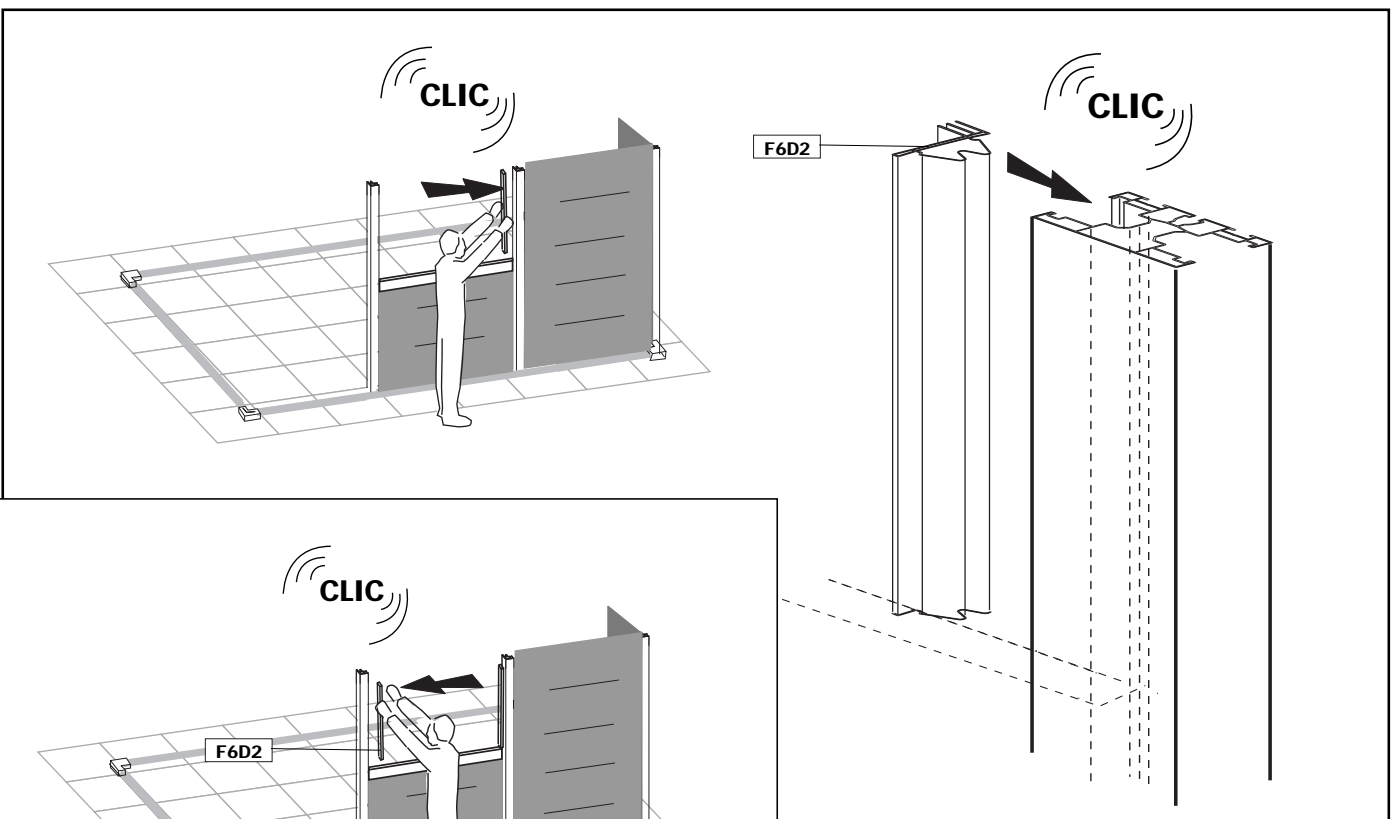
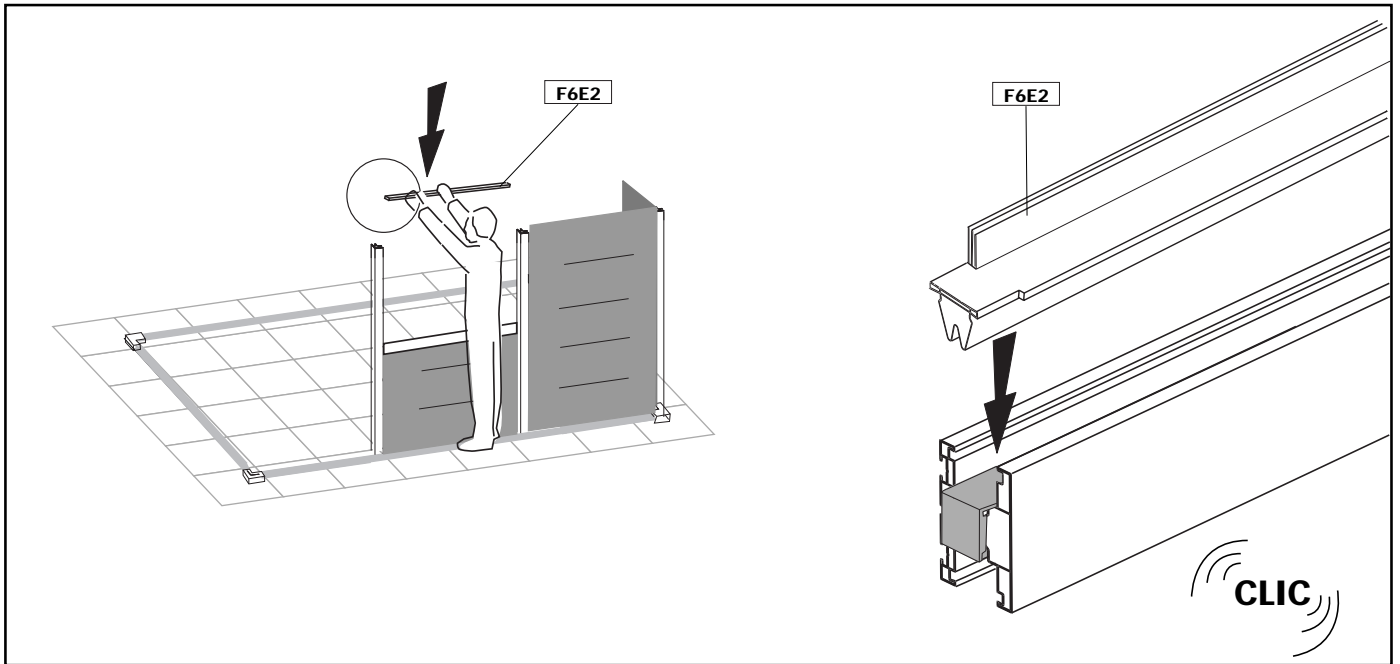
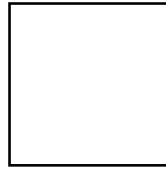
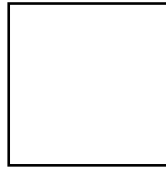
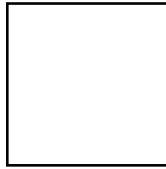
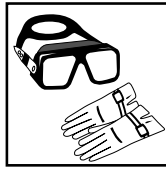

2.12

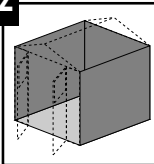

S02F (x1)

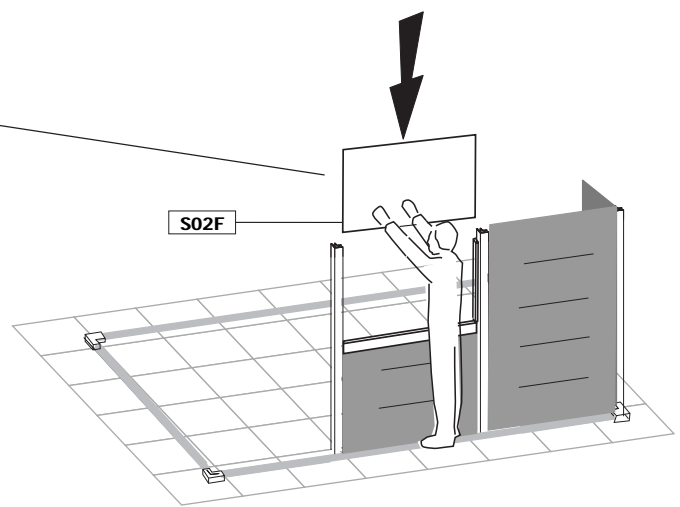
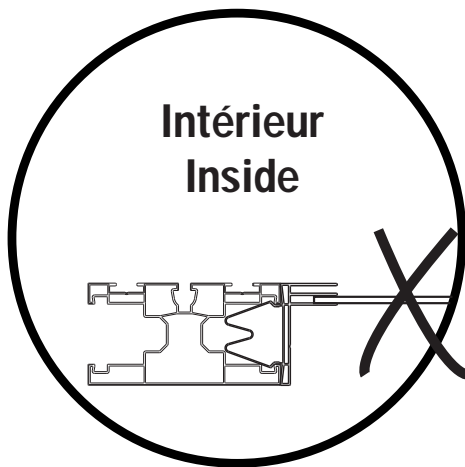
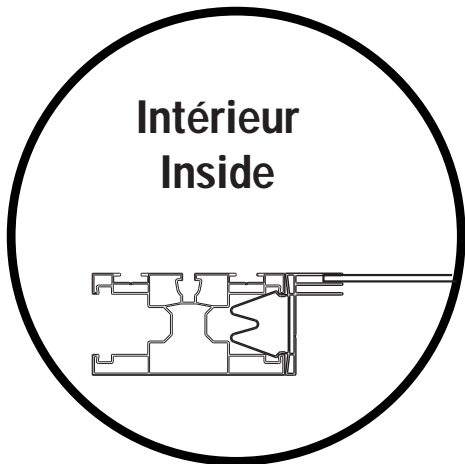

2.13

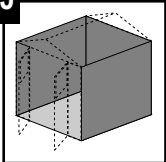

- F1D1 (x1)
- EF2 (x1)
- F6E2 (x1)
- G2 (x2)

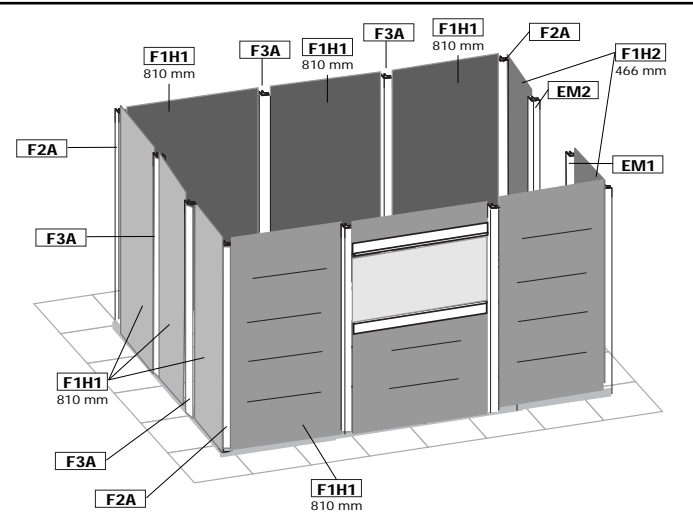
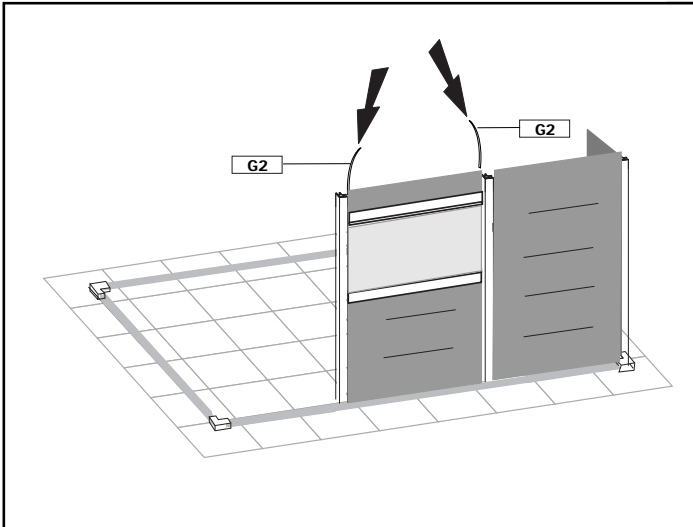
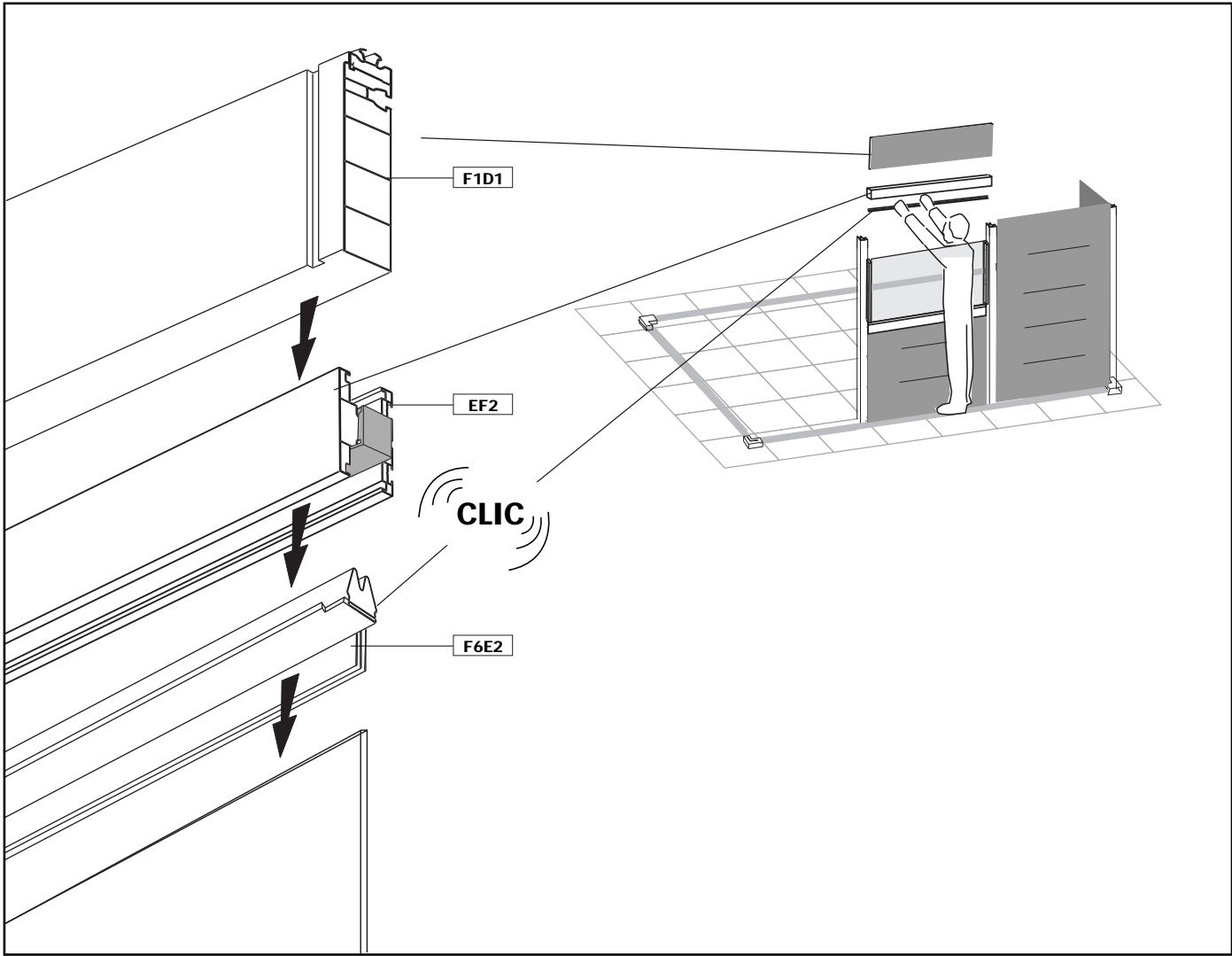

3.1

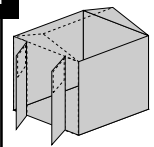

- V04- SH01 (x3)
- V08- SH01 (x3)
- V23- SH01 (x3)
- M02B (x2)

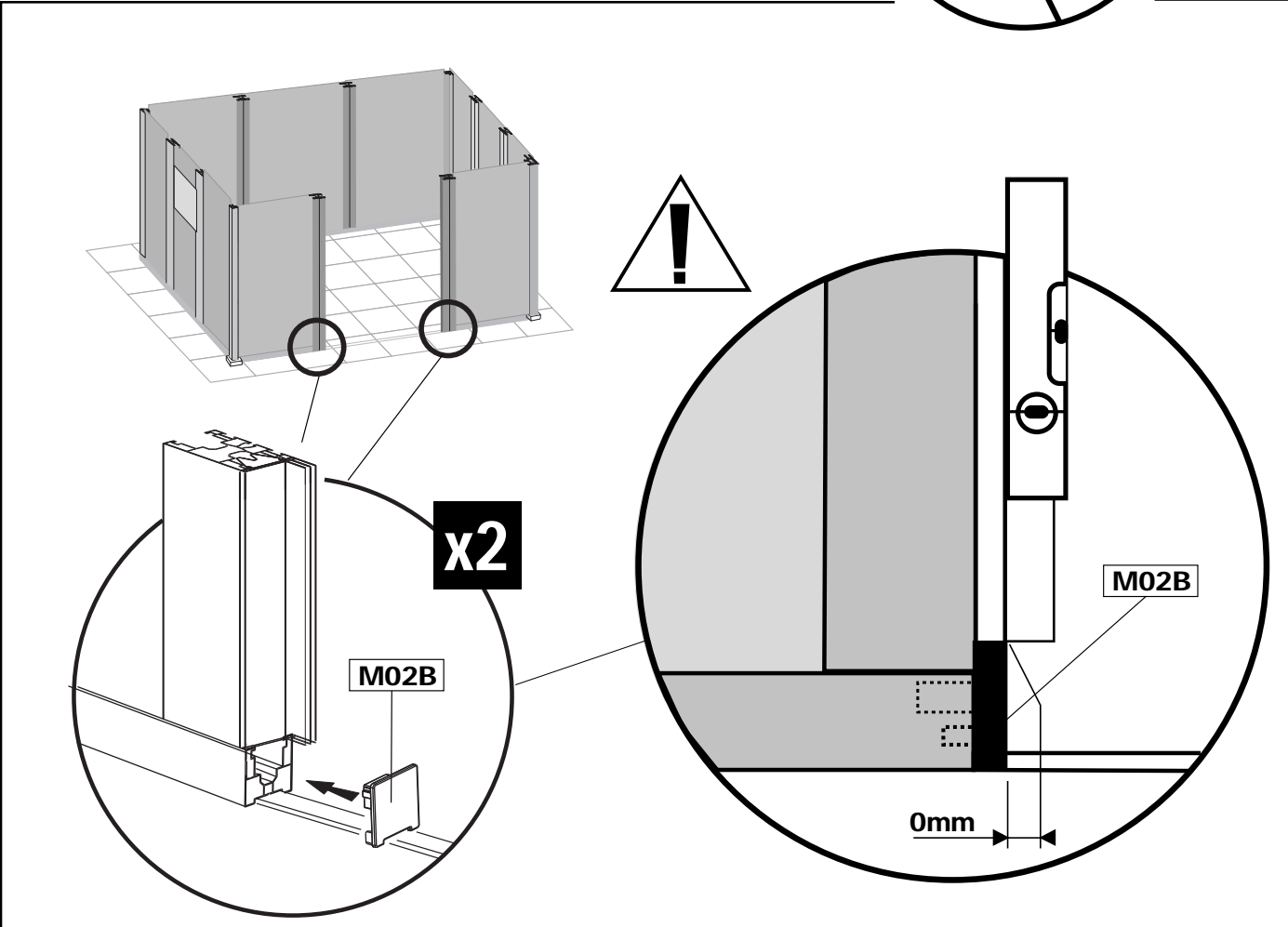
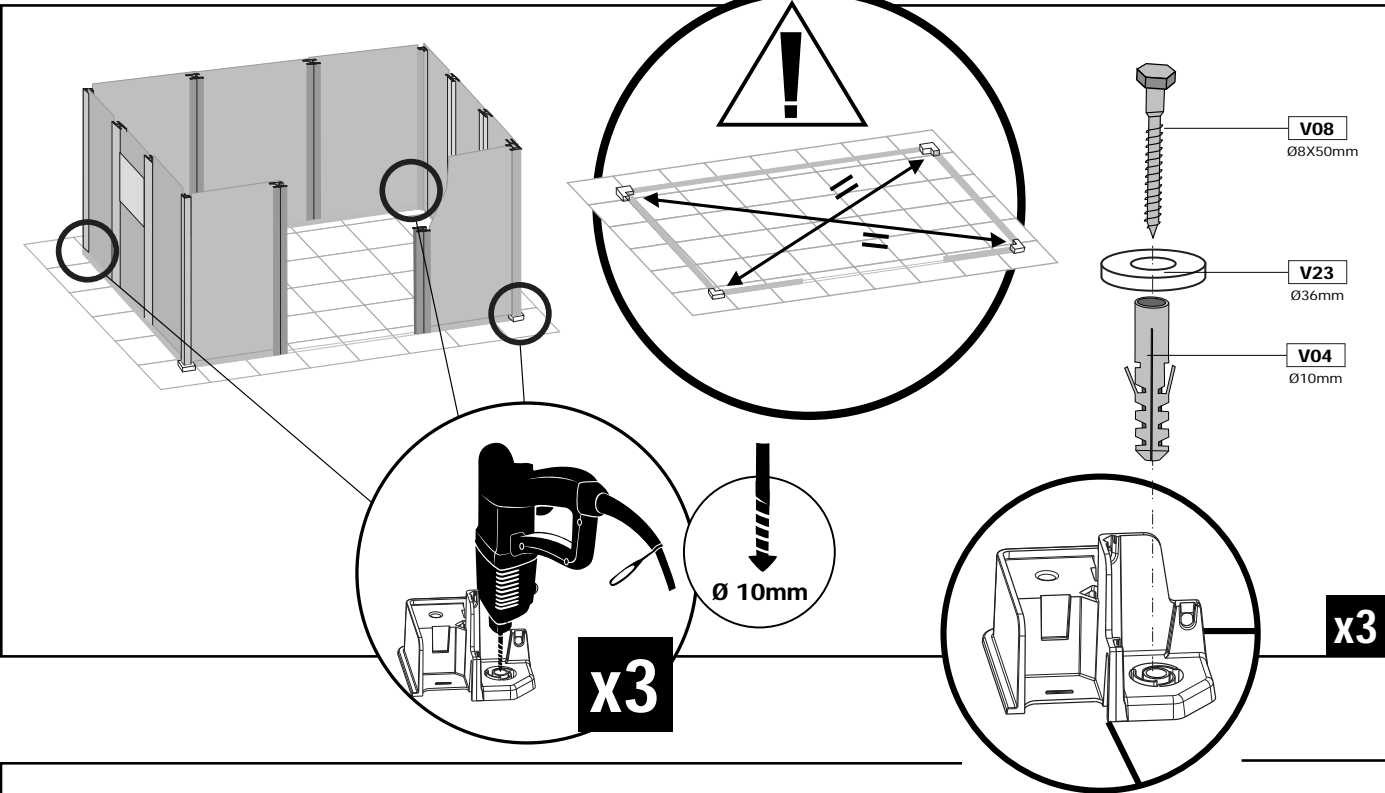
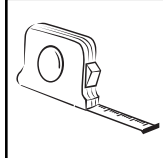
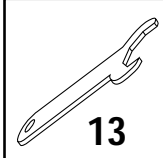
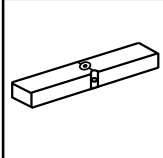

3.2

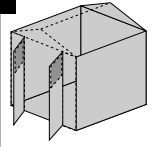

- V03- SH09 (x3) V11- SH02 (x8)
- V20- SH08 (x3) M03 (x2)
- M5D (x1)

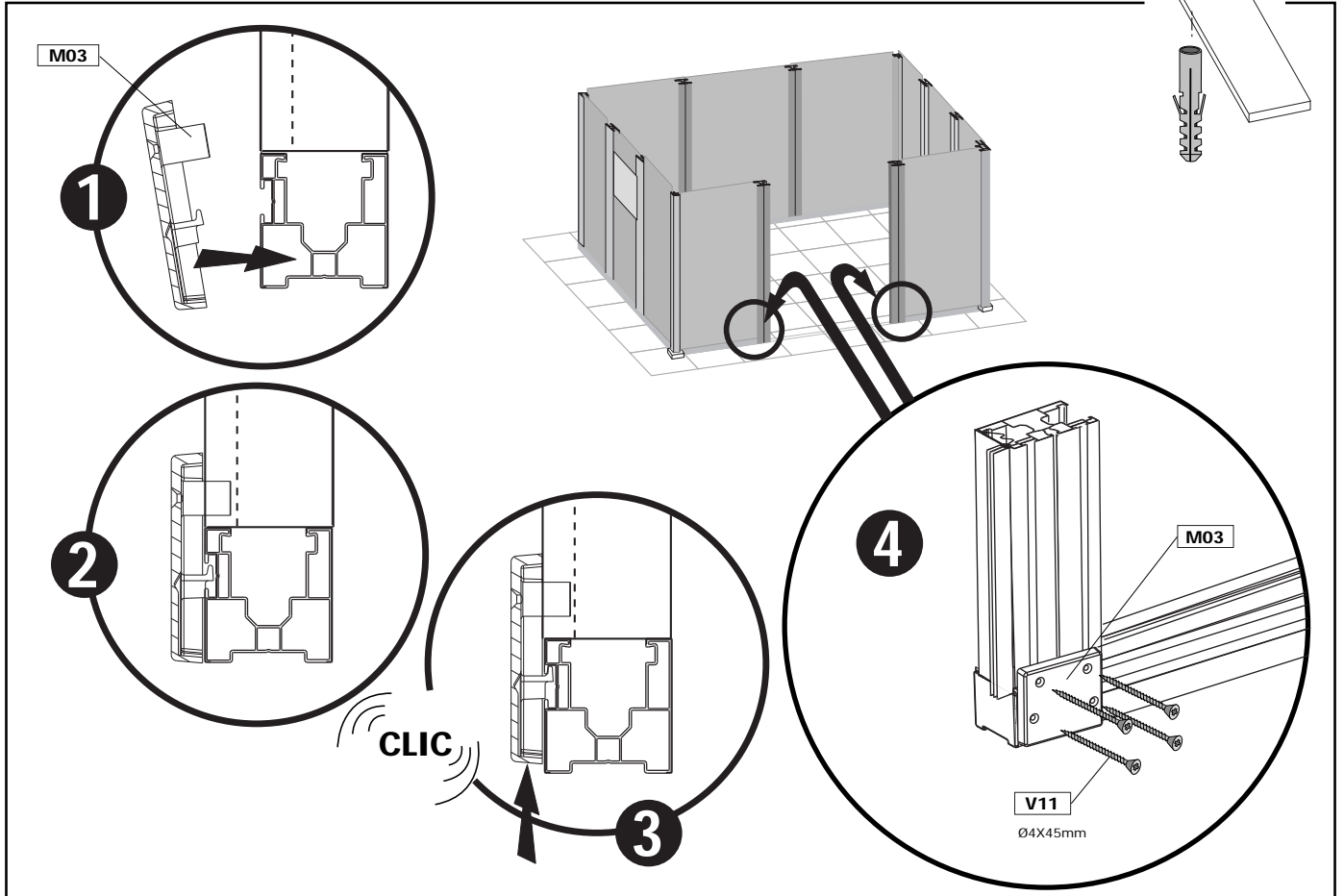
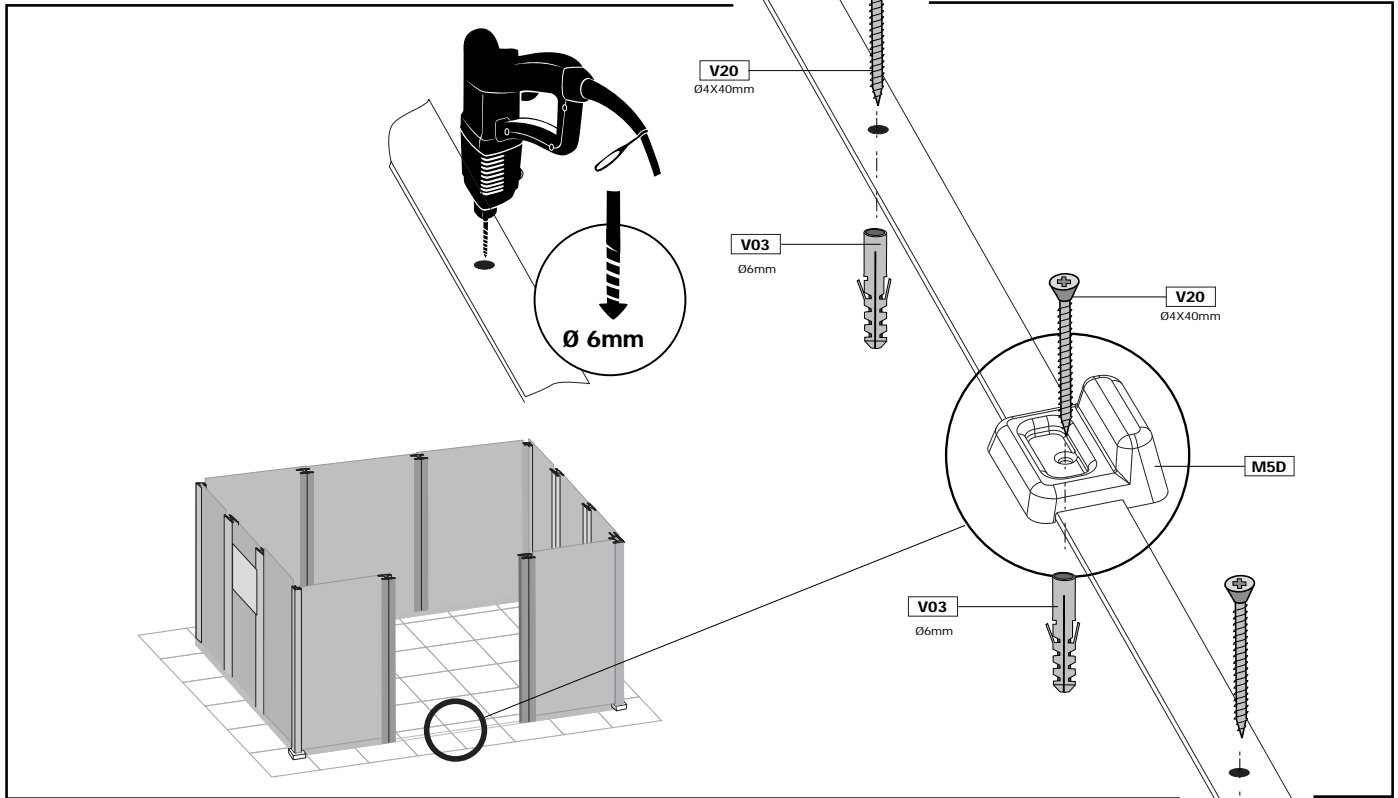
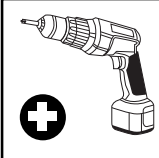

3.3

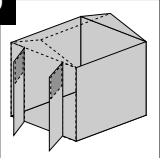

- A03 (x12)
- V03- SH09 (x12)
- V16- SH05 (x12)
- V22- SH07 (x12)

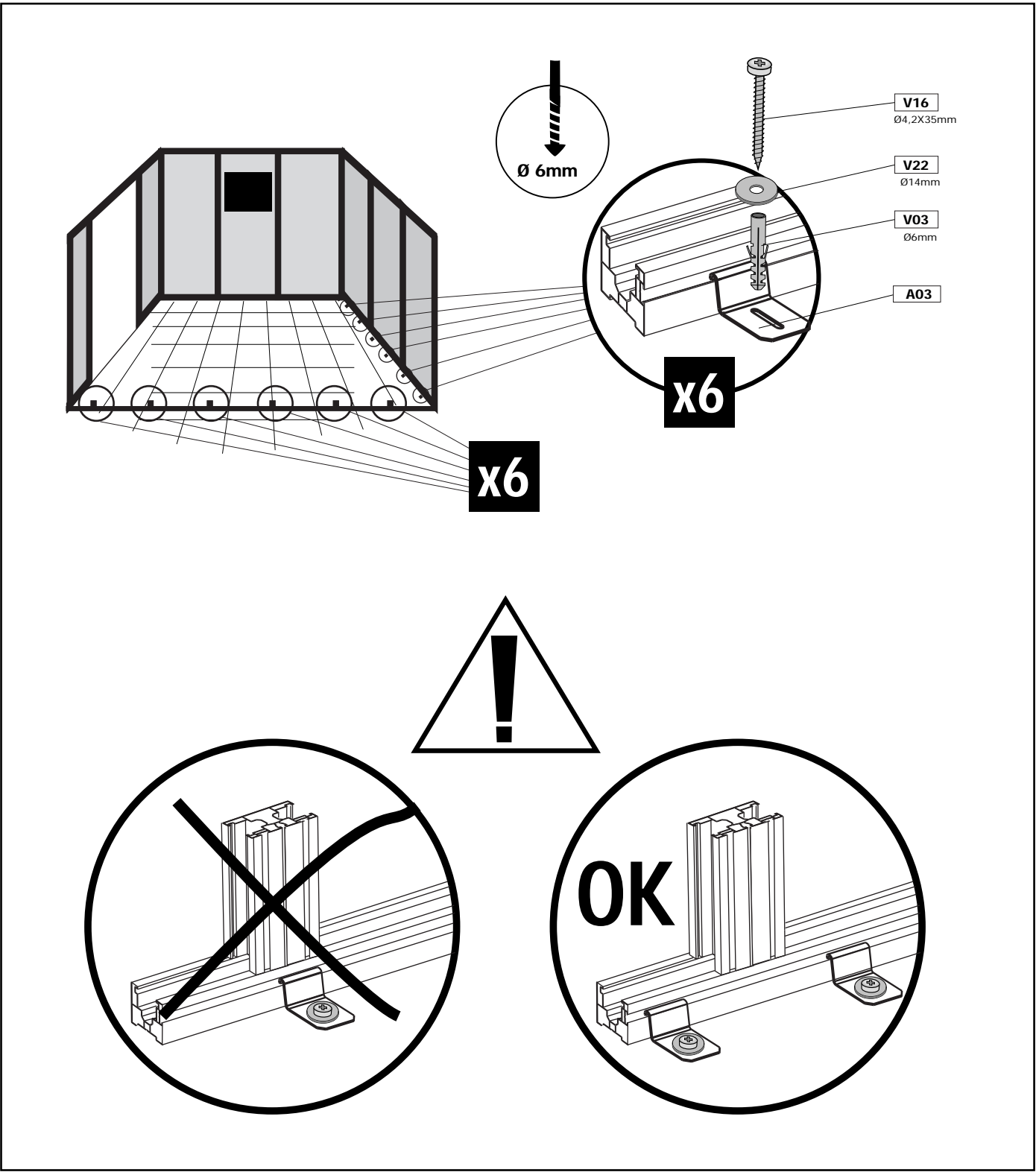
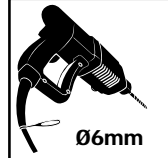
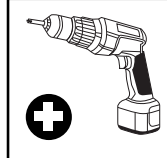

3.4

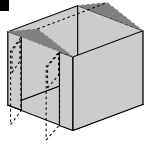

- F4B4 (x2)
- F4B6 (x2)
- V13- SH03 (x8)
- A02 (x2)

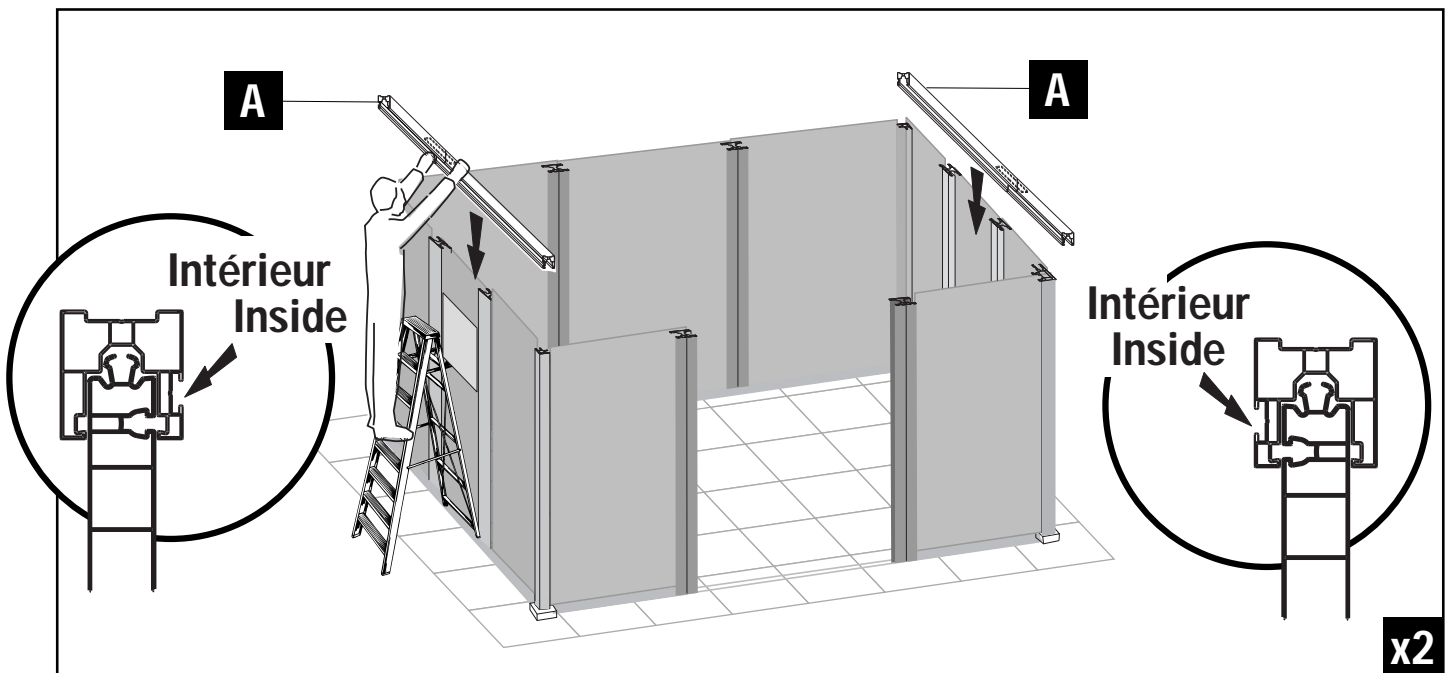
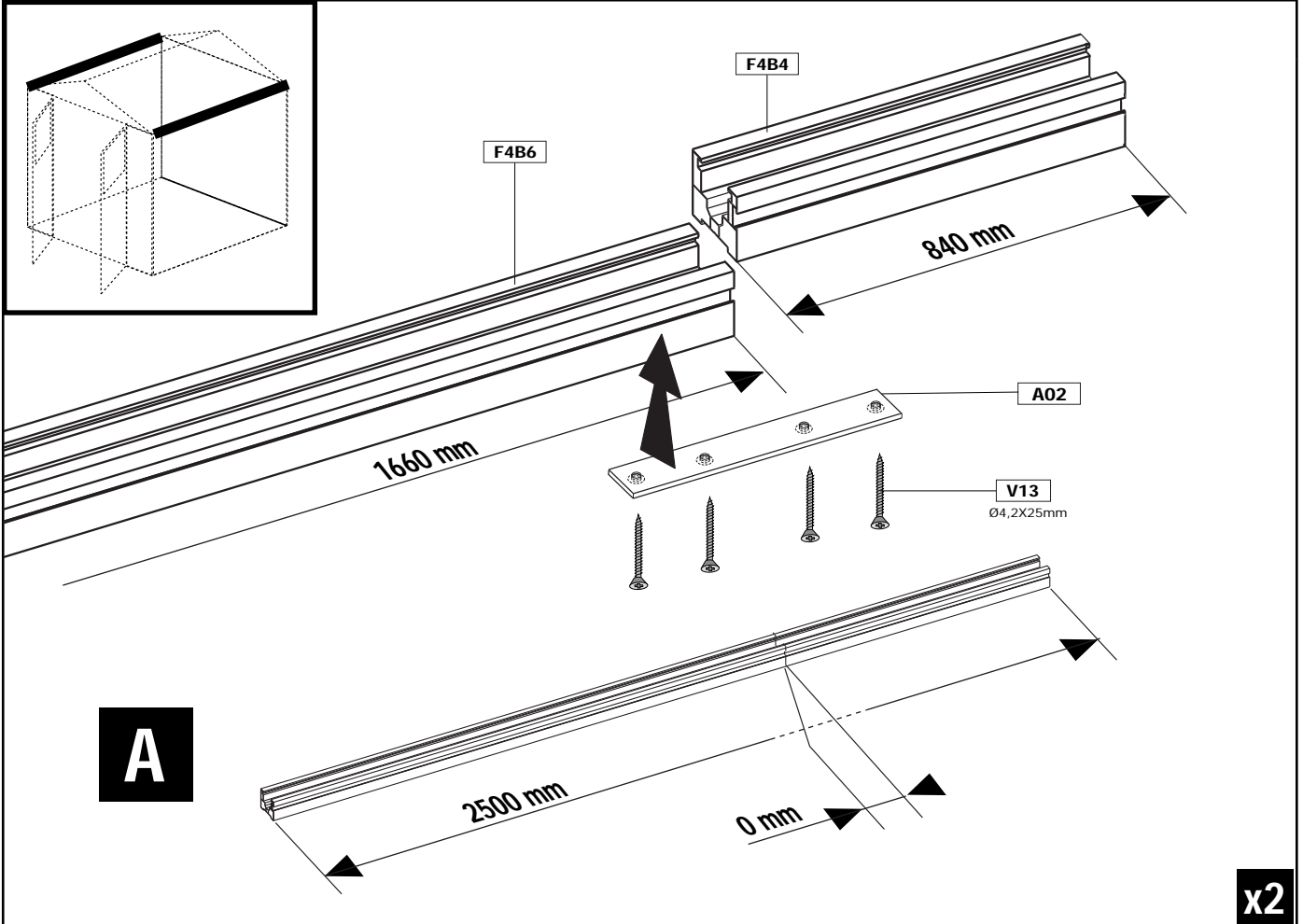
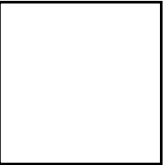
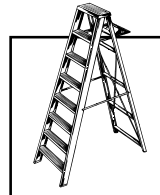
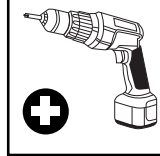
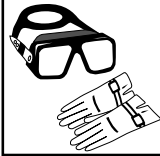

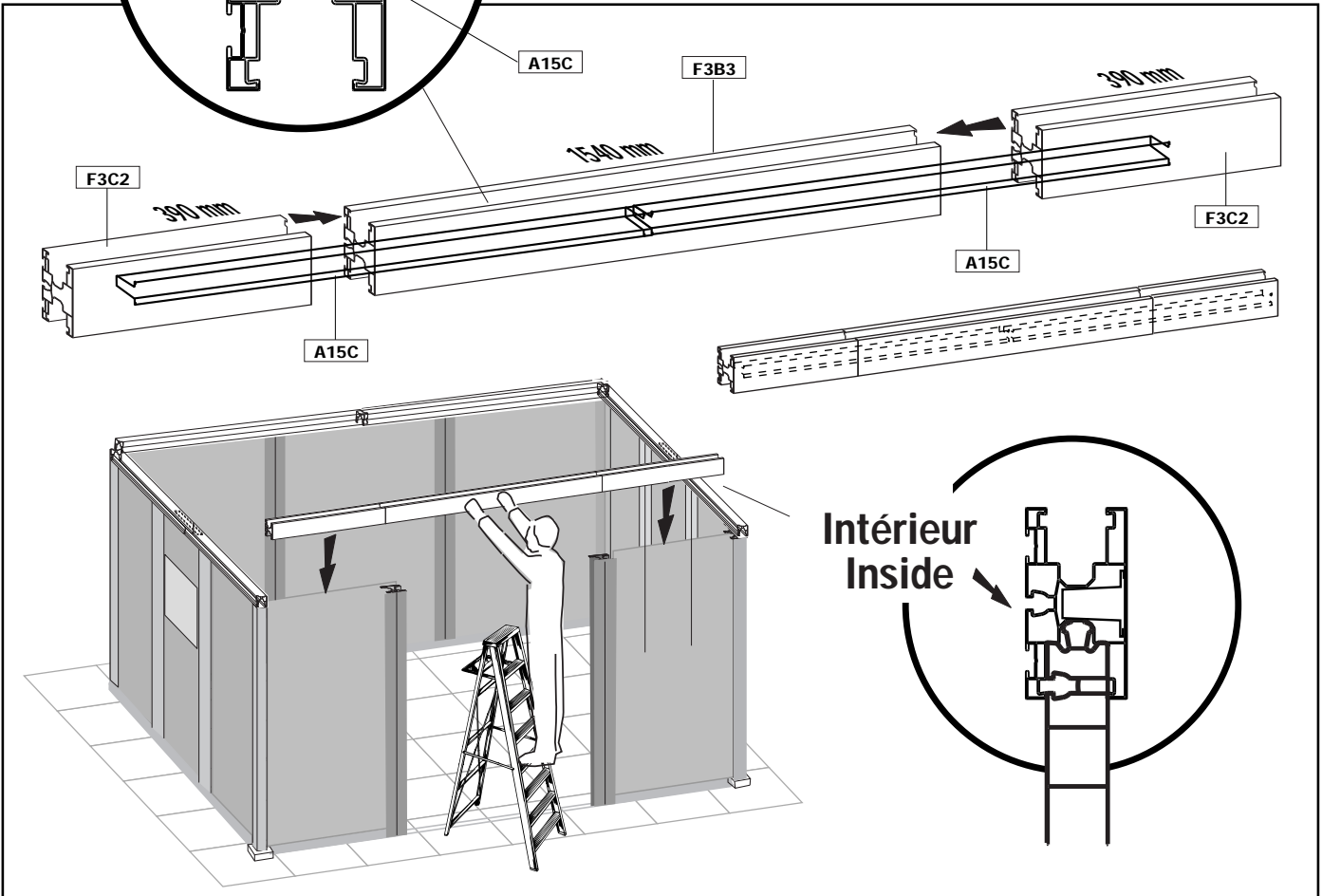
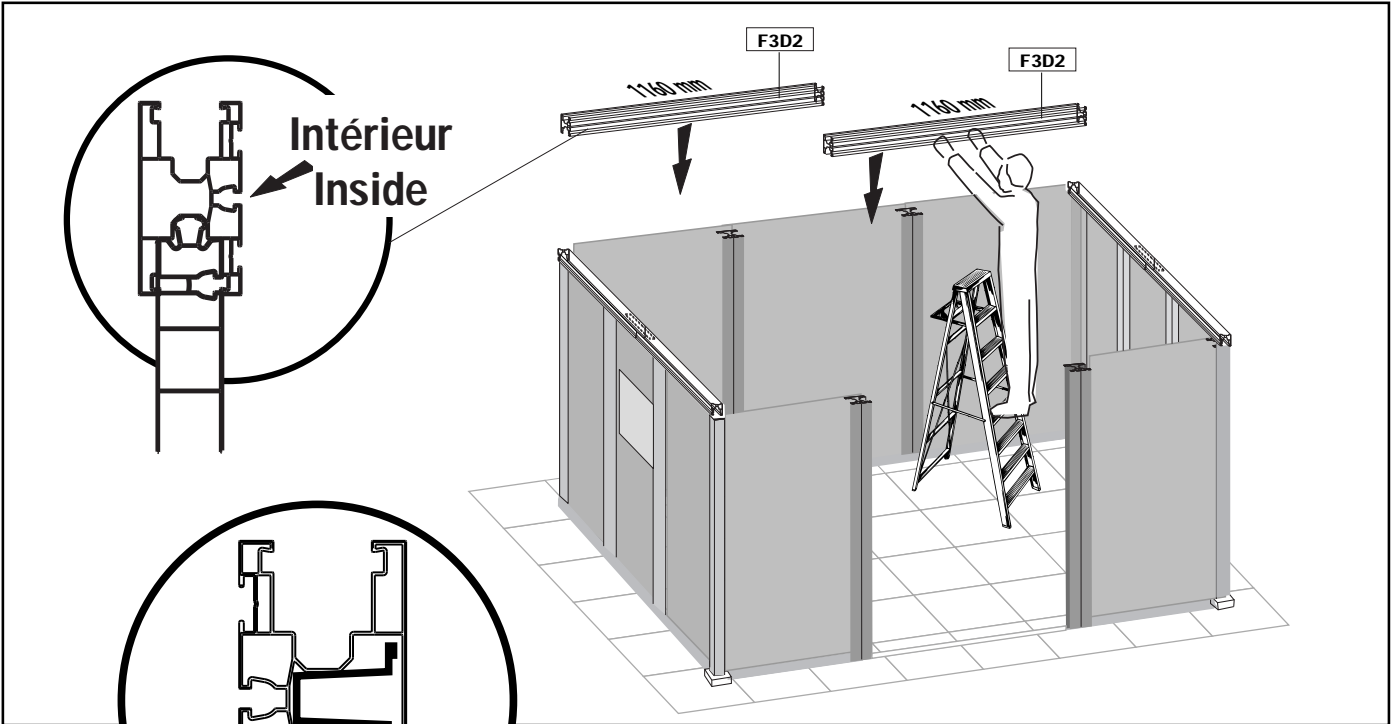

3.5

	F3D2 (x2)	F3C2(x2) F3B3 (x1) A15C (x2)					
--	------------------	---	--	--	--	--	--

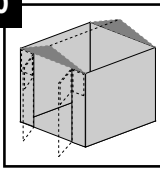
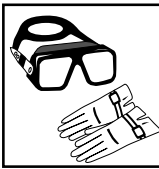

3.6

	F6A2 (x1)	M1A1 (x2) M1A2 (x2)					
---	------------------	--------------------------------------	---	--	--	--	--

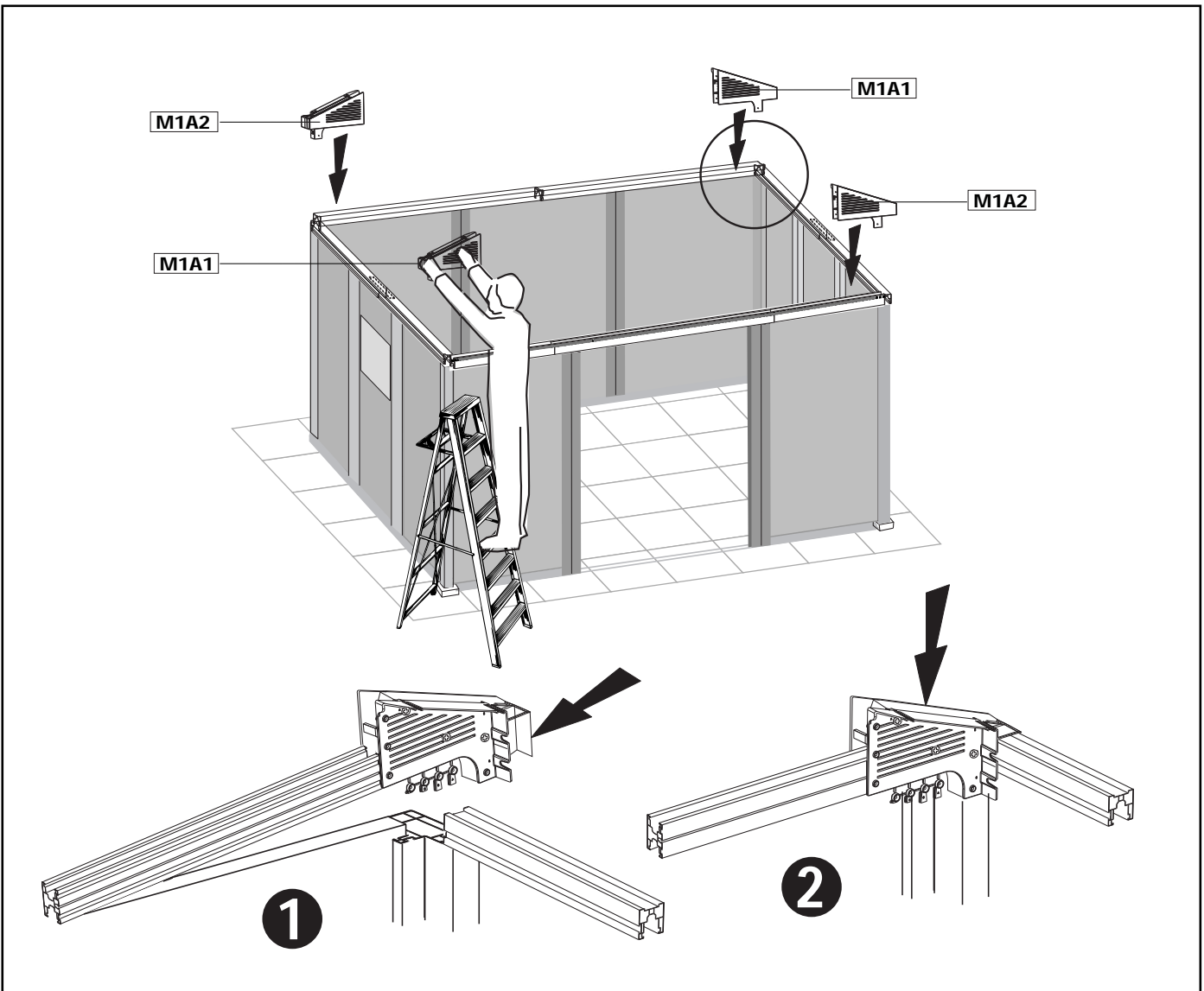
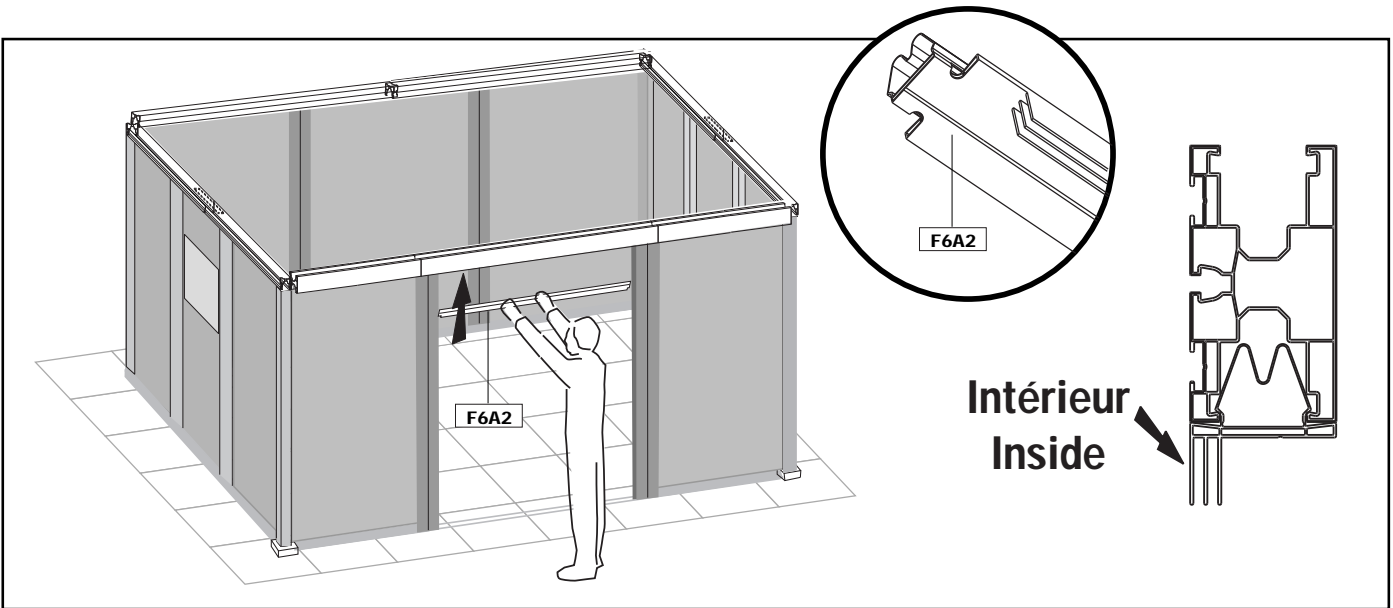

3.7

	<p>M06A (x2) V01-SH04 (x8) V22-SH07 (x8)</p>	<p>ET4 (x2)</p>				
--	---	------------------------	--	--	--	--

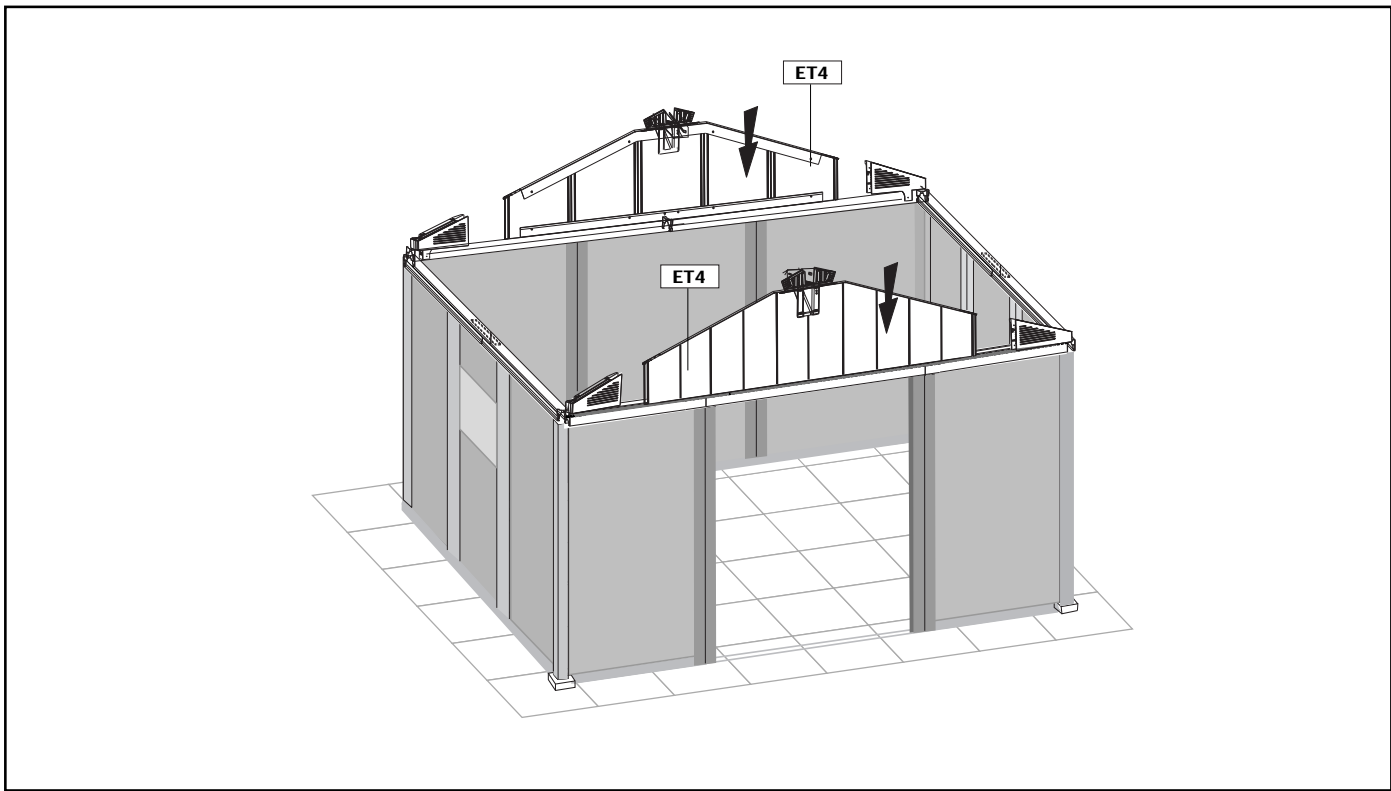
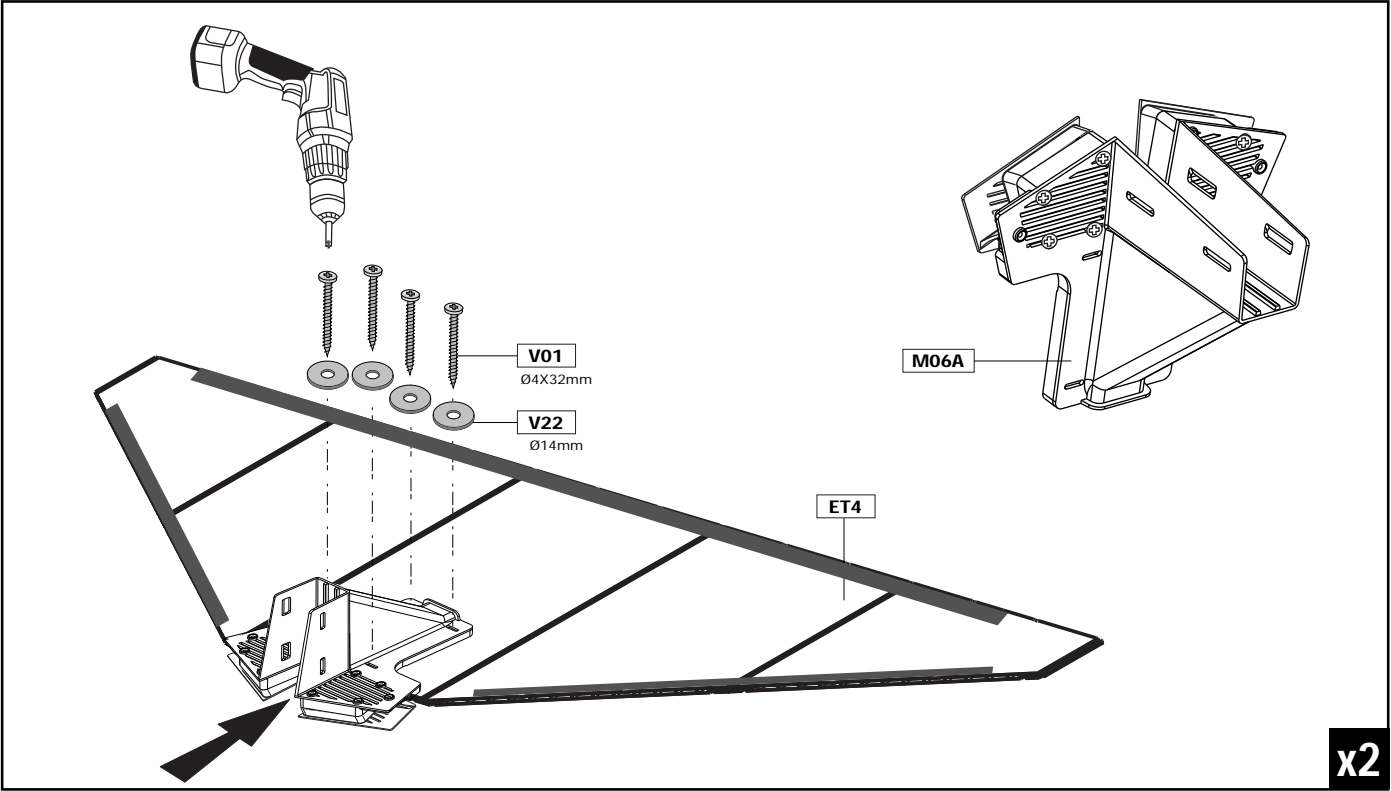

3.8

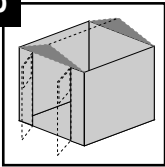

T4-1 (x2)
T4-2 (x2)

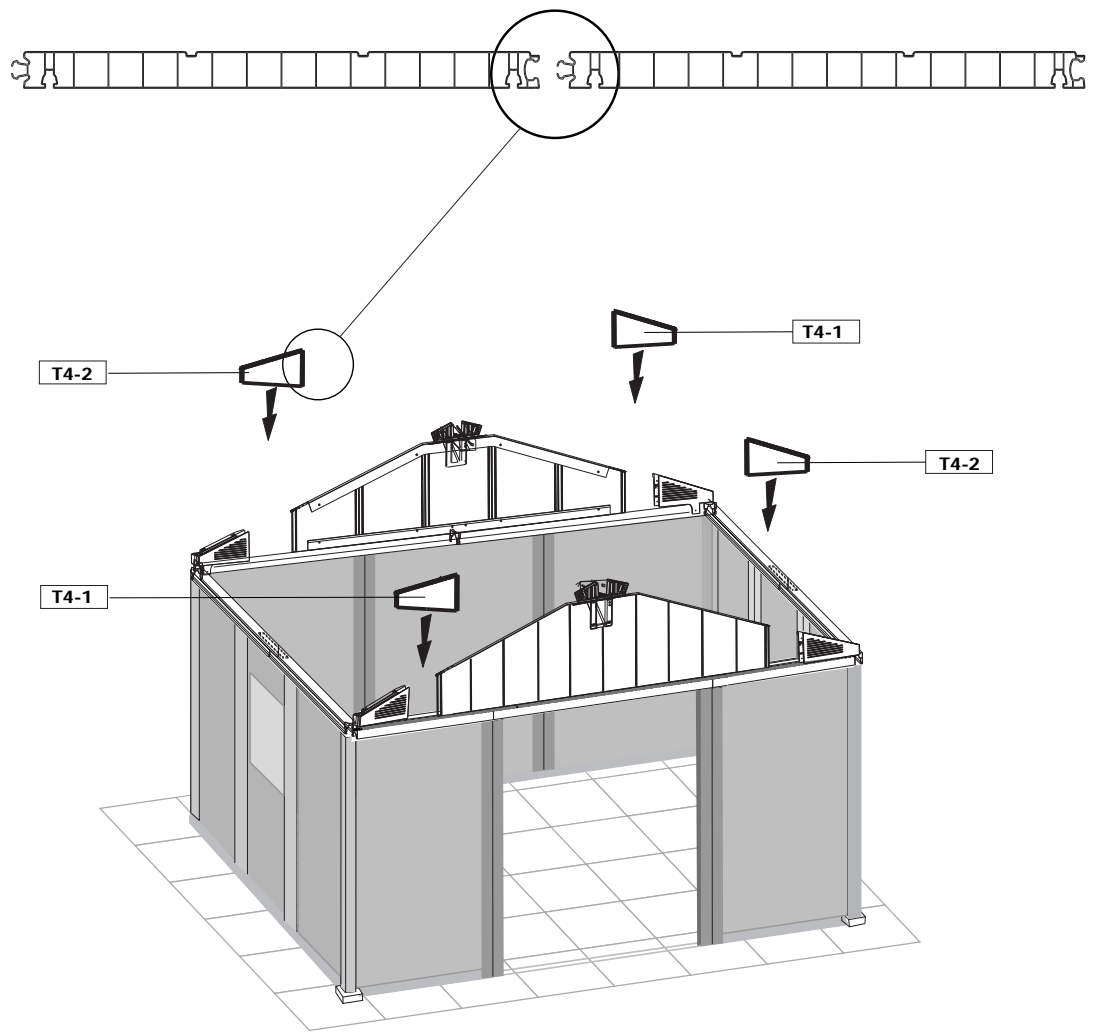
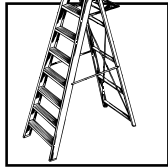

x2

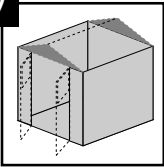

3.9

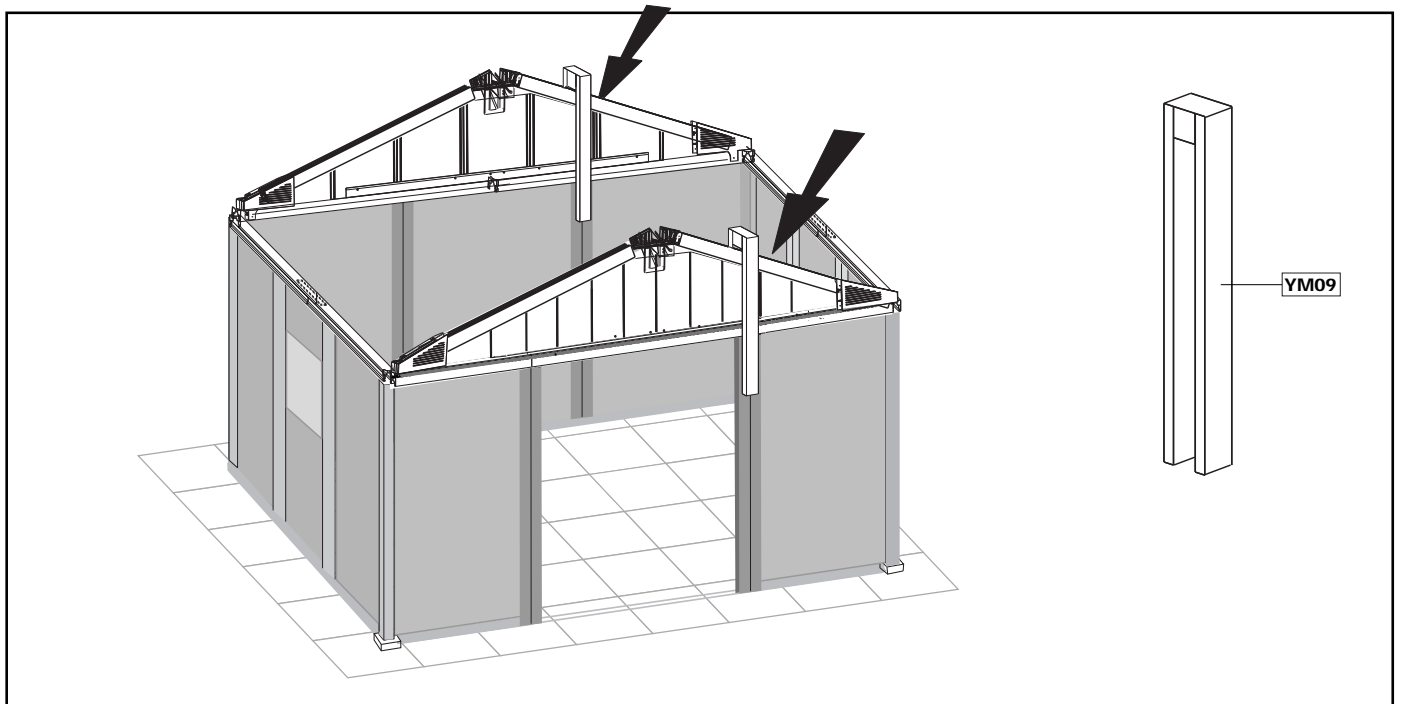
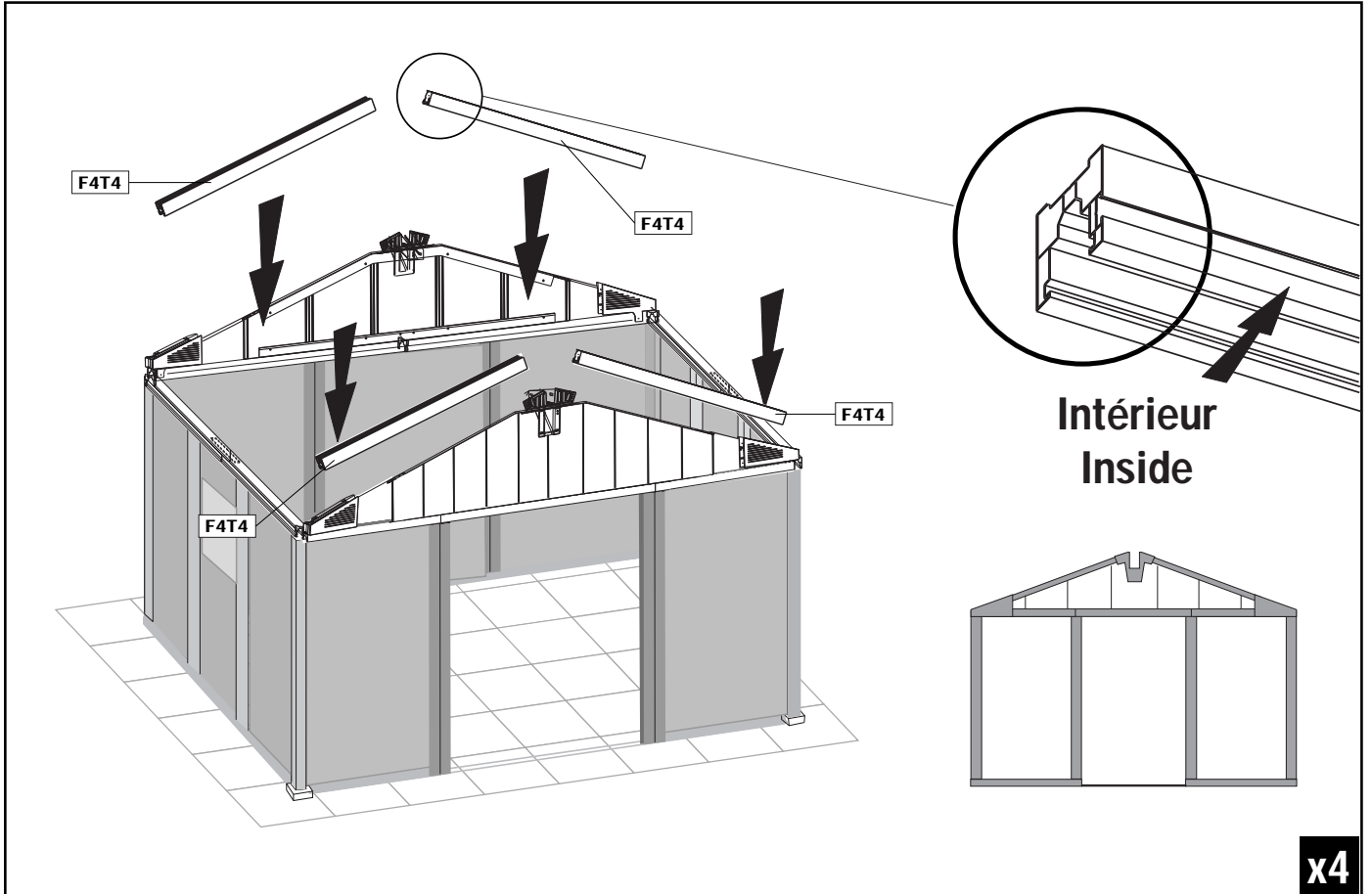
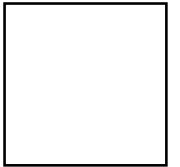
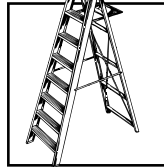

F4T4 (x4) **YM09 (x2)**

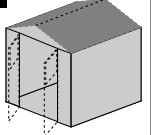

4.1

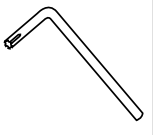
	EA2A (x1) EA2B (x1)					
---	------------------------	---	--	--	--	--

1

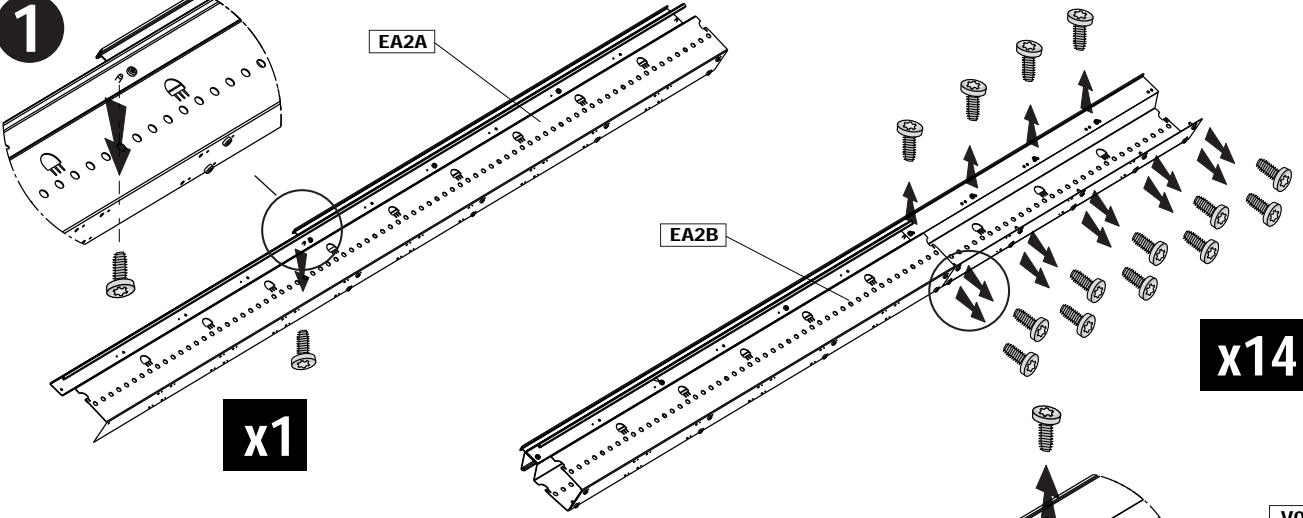

EA2A

EA2B

x1

x14

V07
Ø4x8mm

2

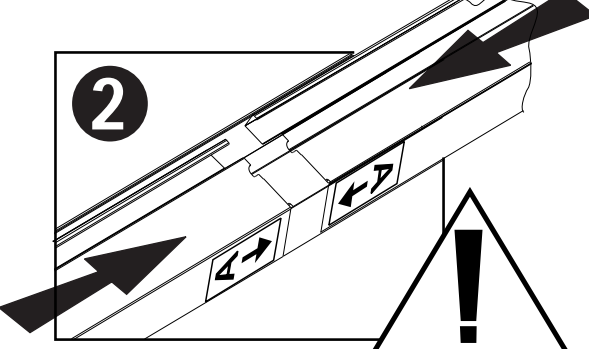

!

3

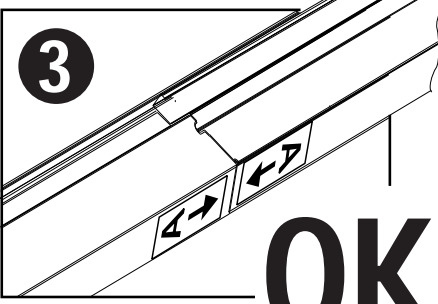

OK

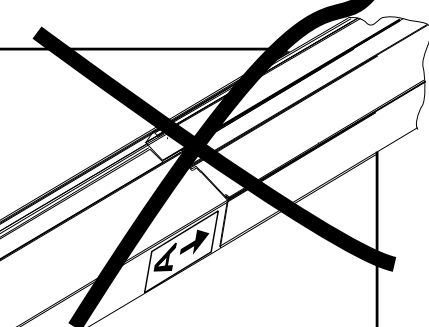

4

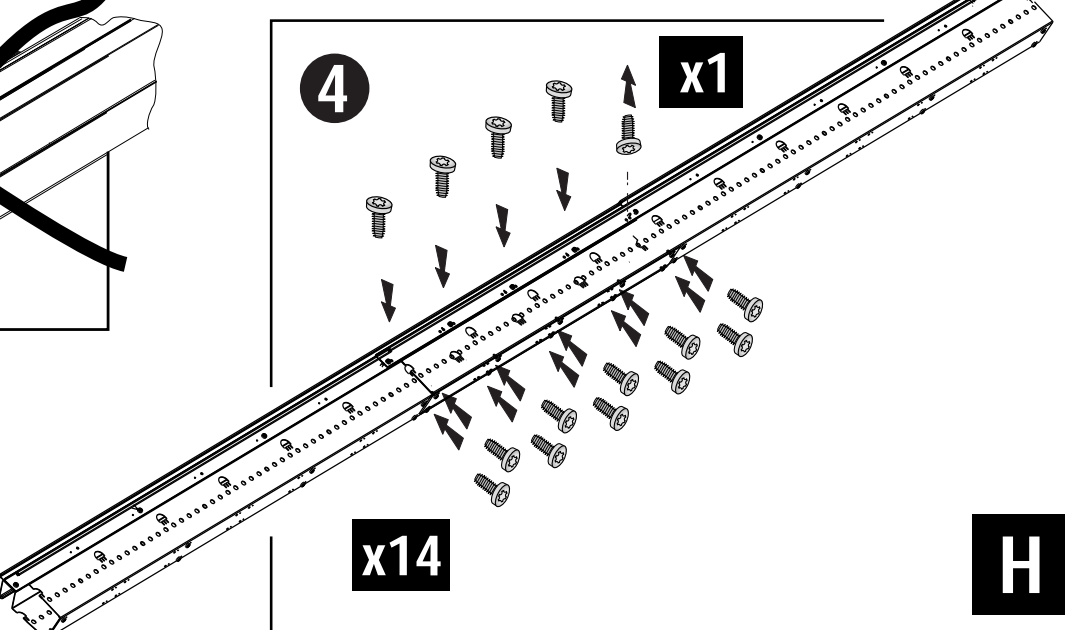

x1

x14

H

4.2

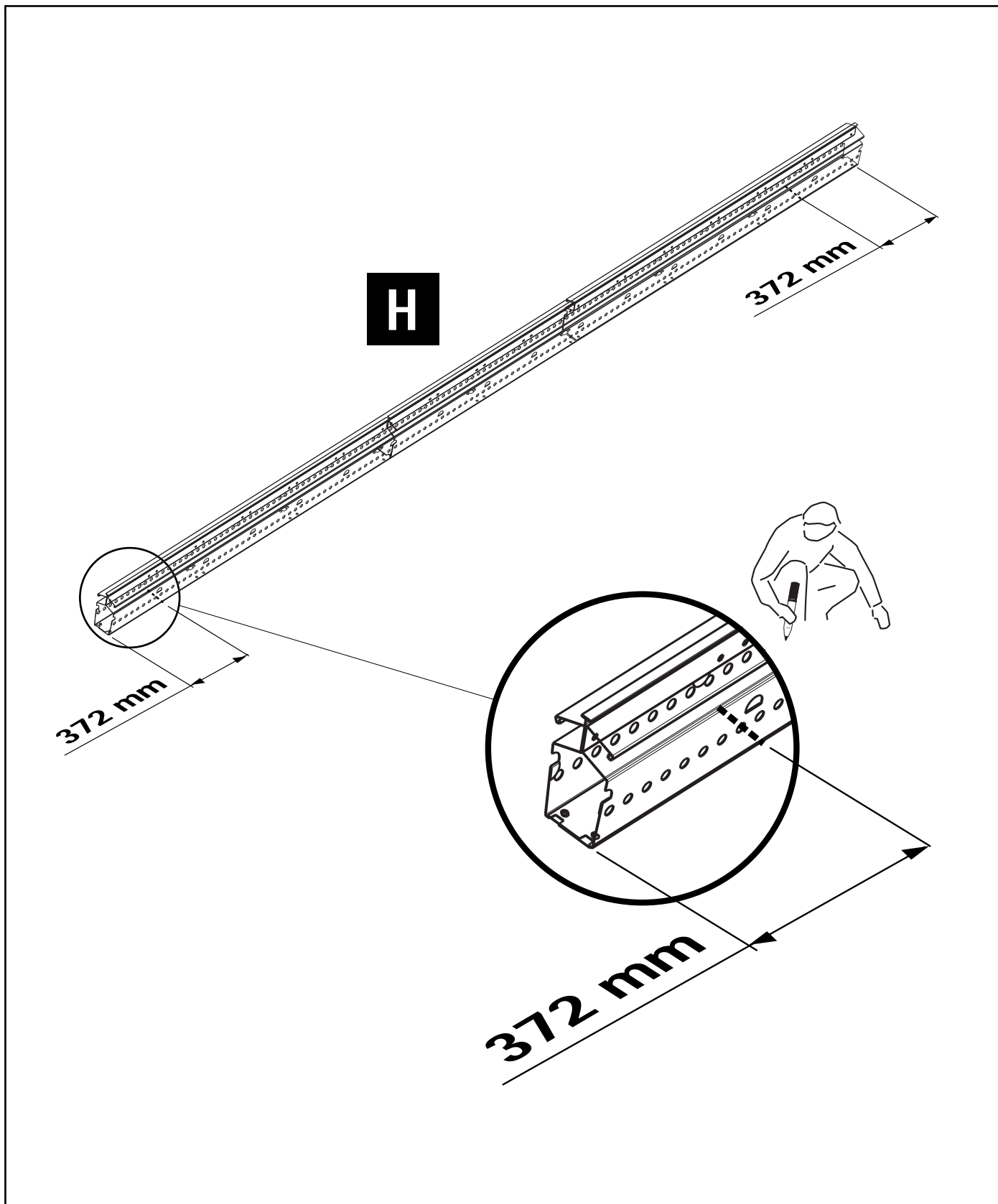
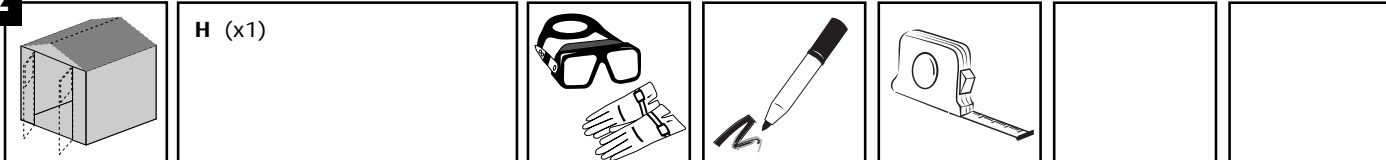

4.3

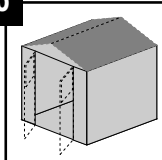

H (x1)
V05- SH06 (x4)
V06- SH06 (x4)
V21- SH06 (x8)

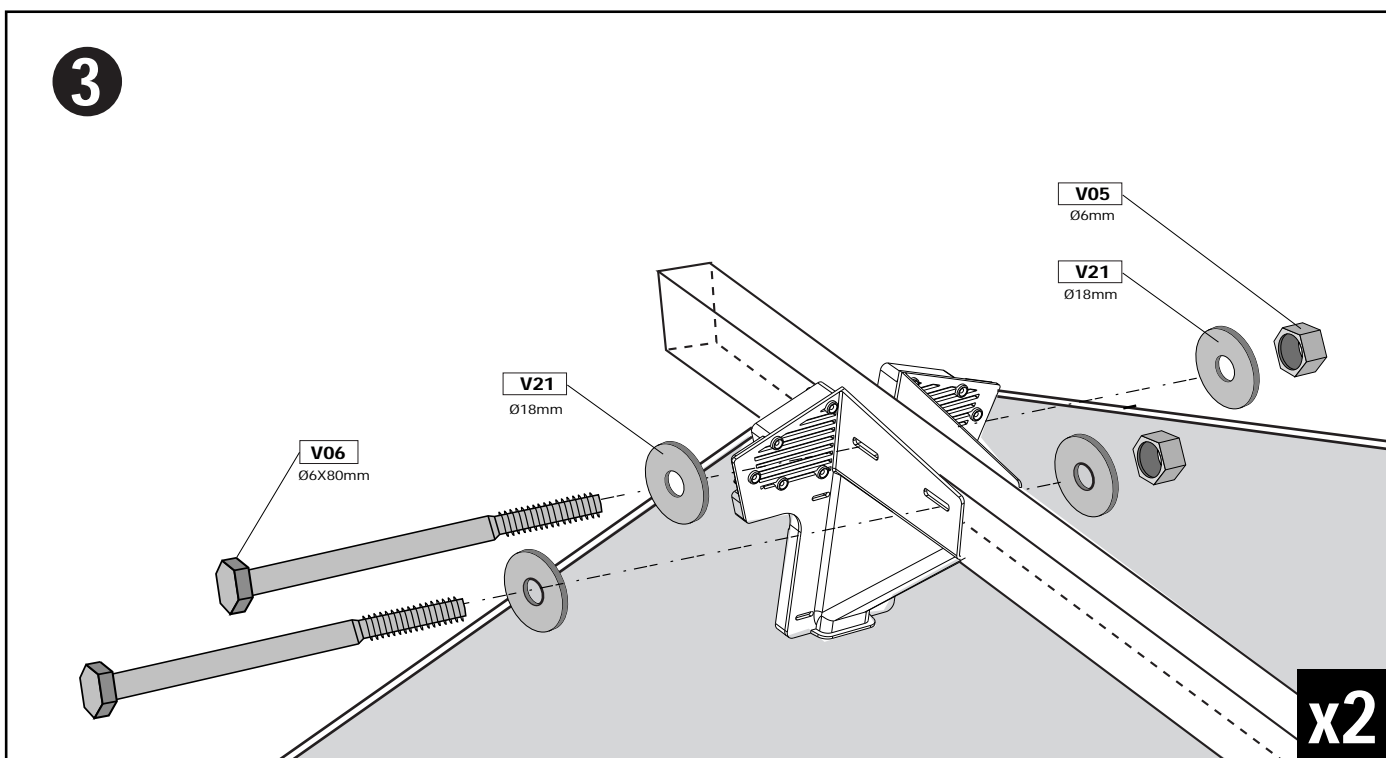
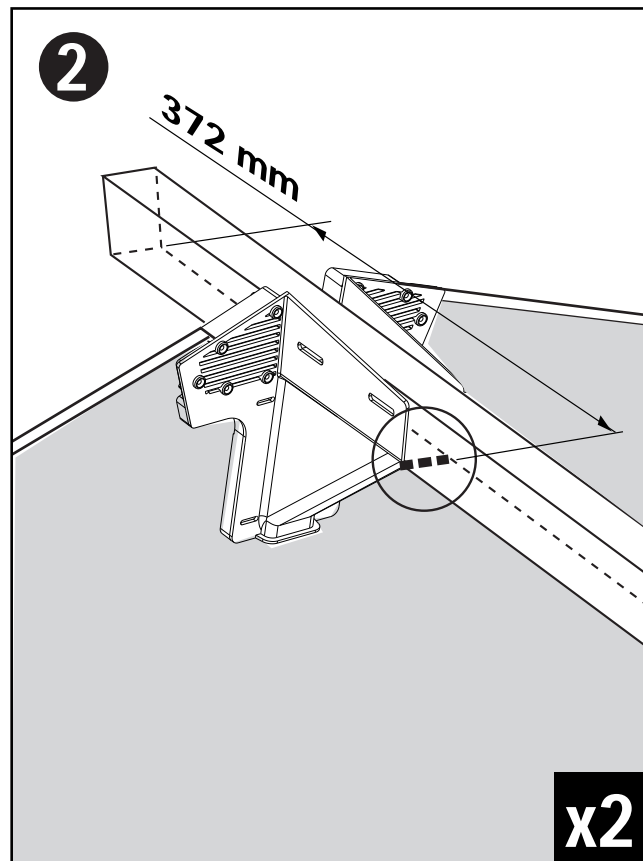
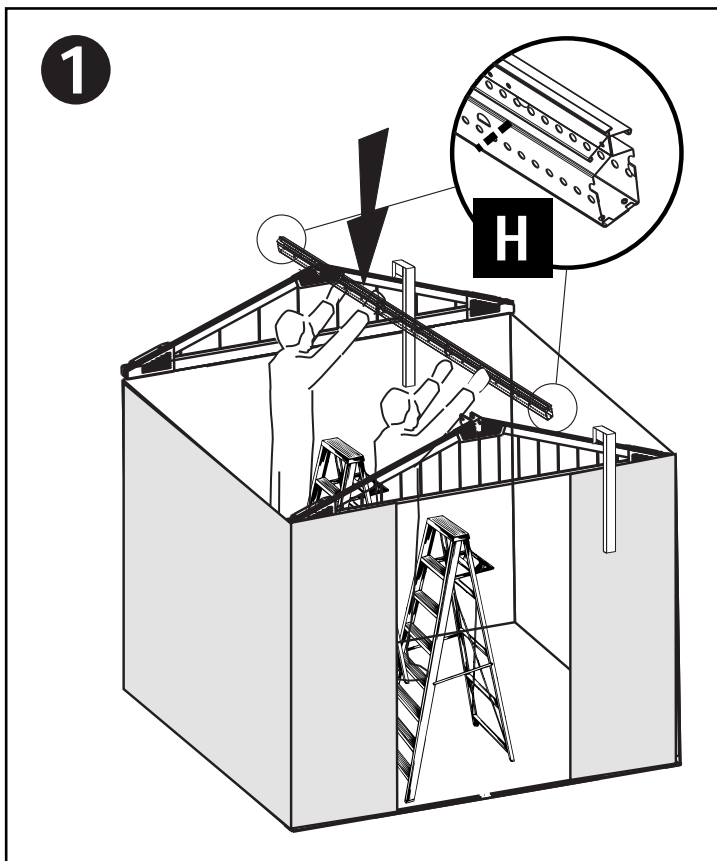
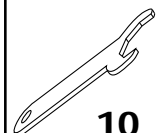
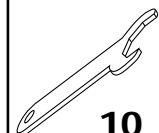
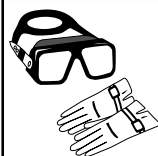

4.4

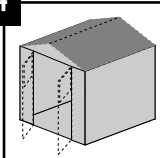

F1T4 (x16)

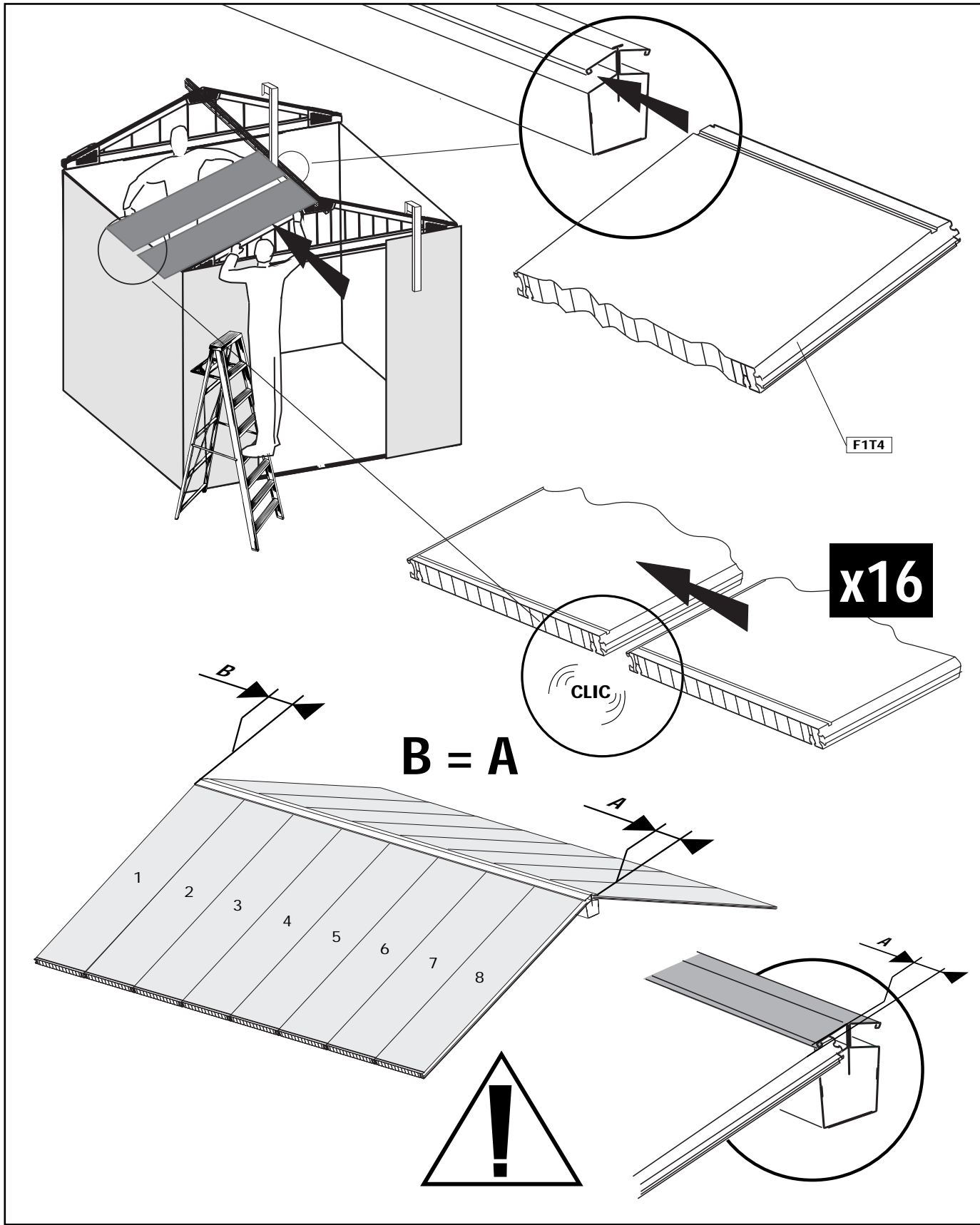
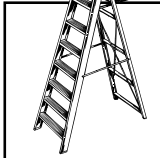

4.5

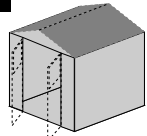

A12D (x6)

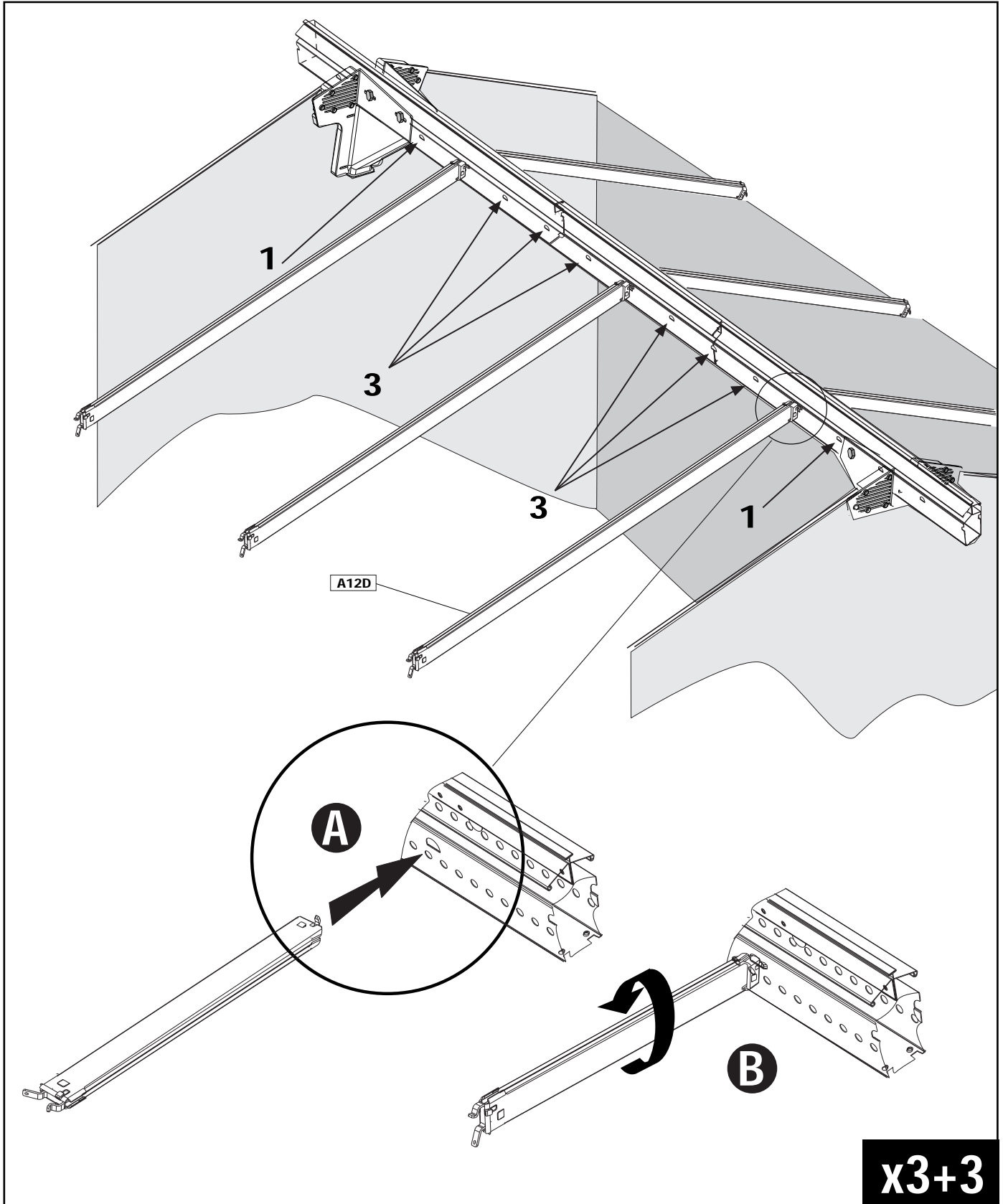

x3+3

5.1

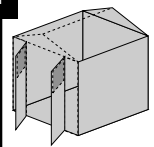

- FP113 (x1)
- K10 (x1)
- EP1D (x1)
- EP2D (x1)

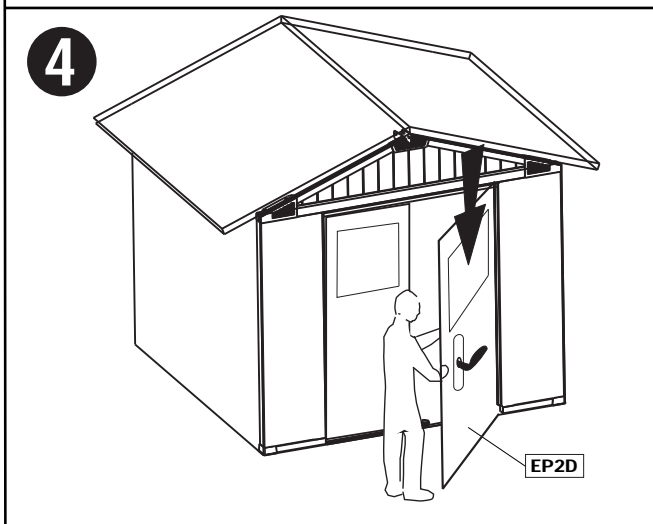
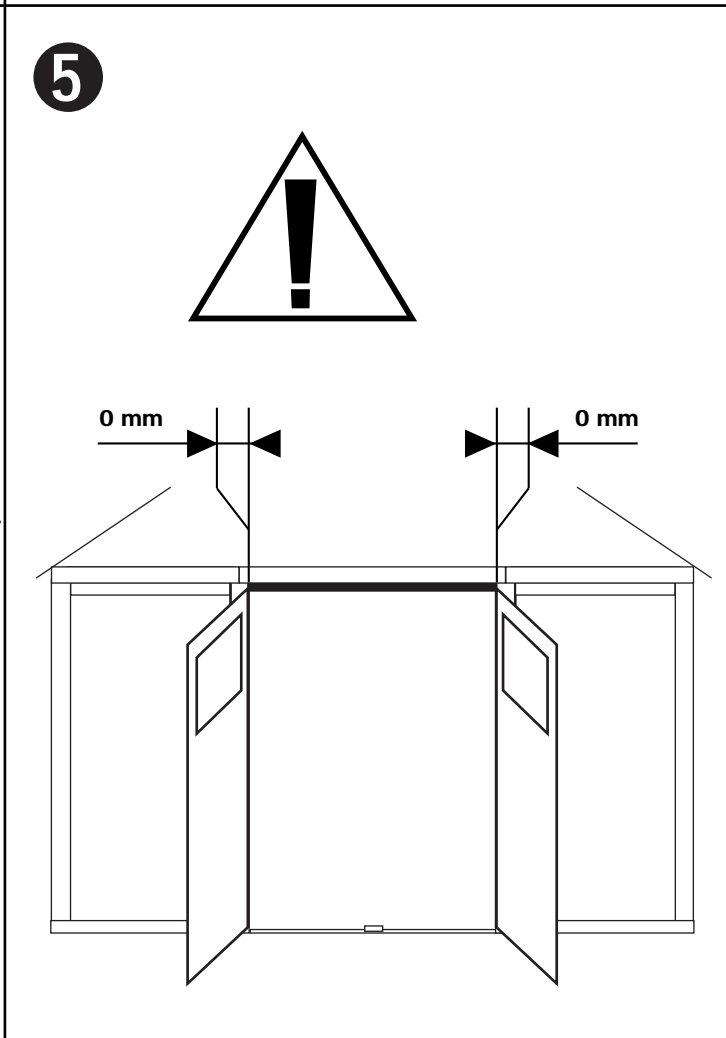
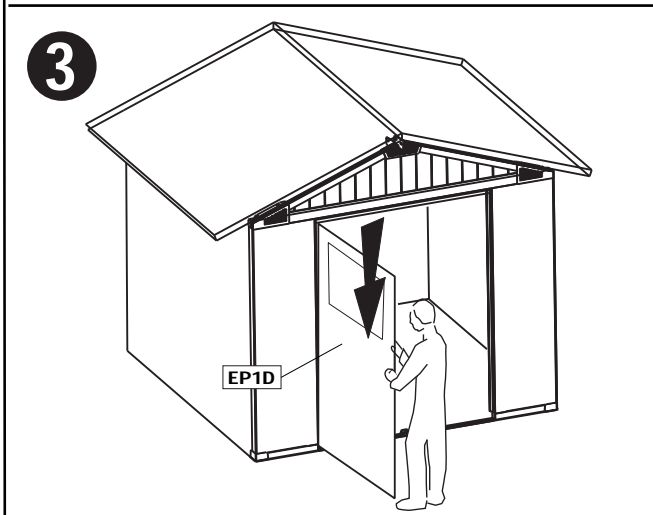
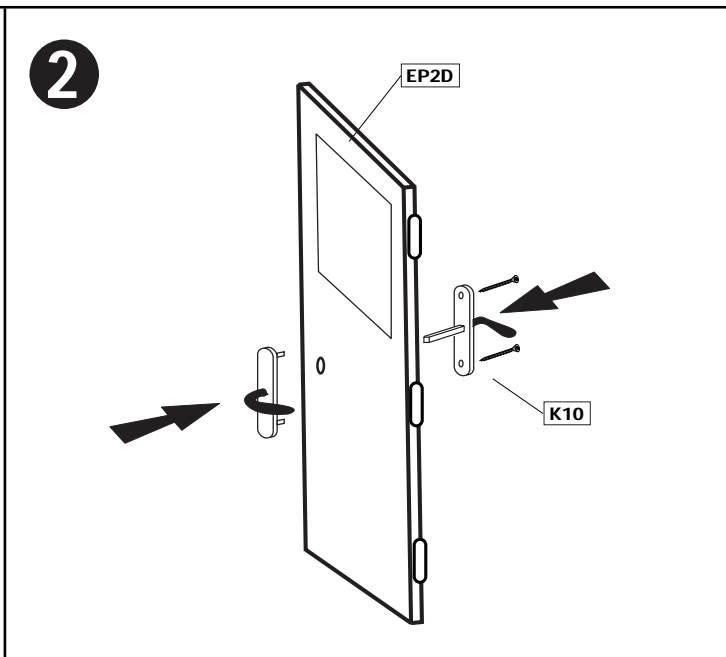
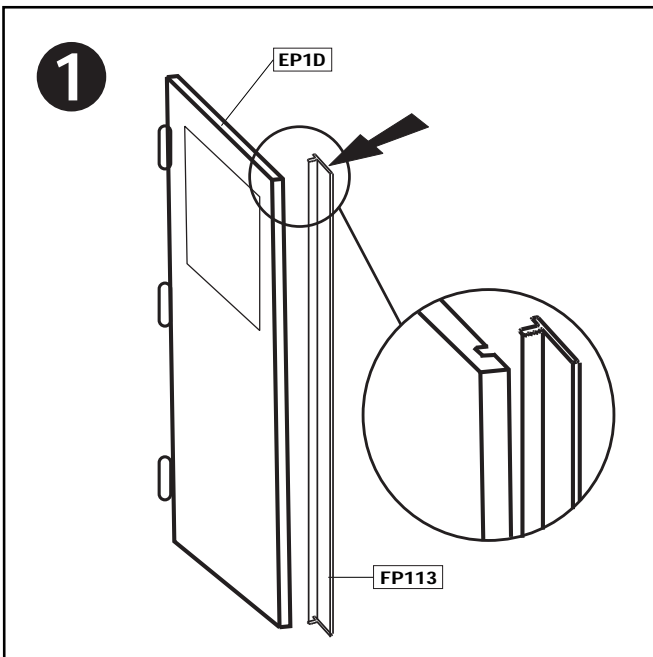
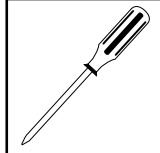

5.2

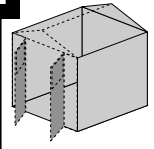

V11- SH02 (x16)
M03 (x4)

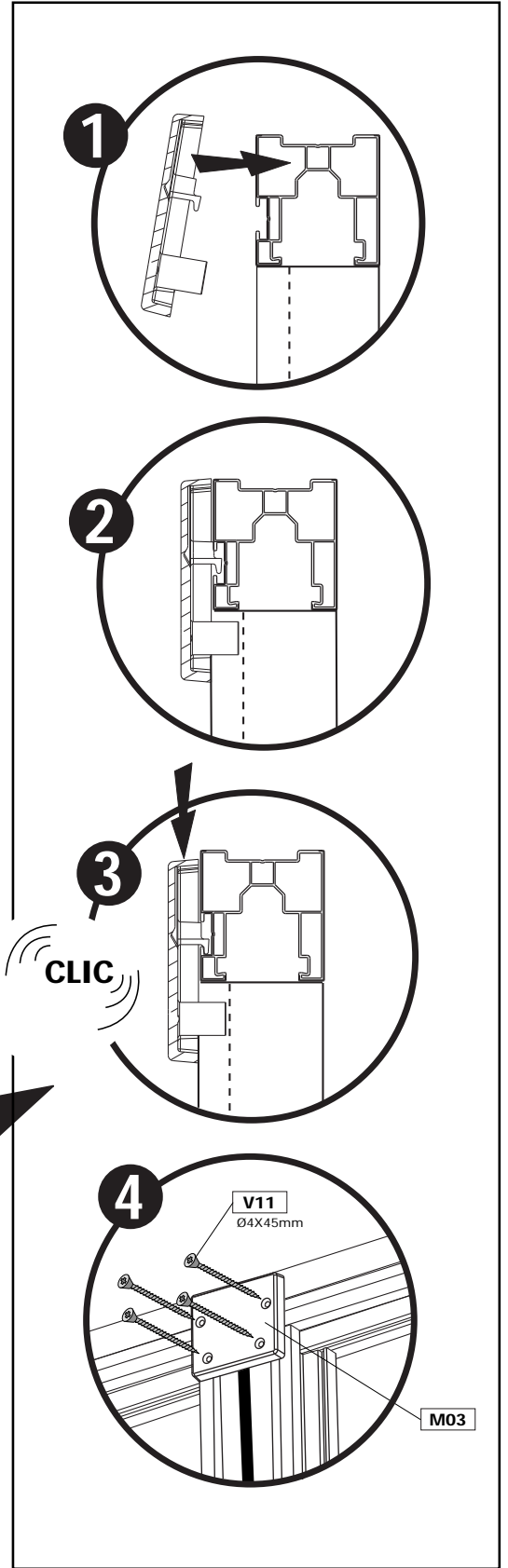
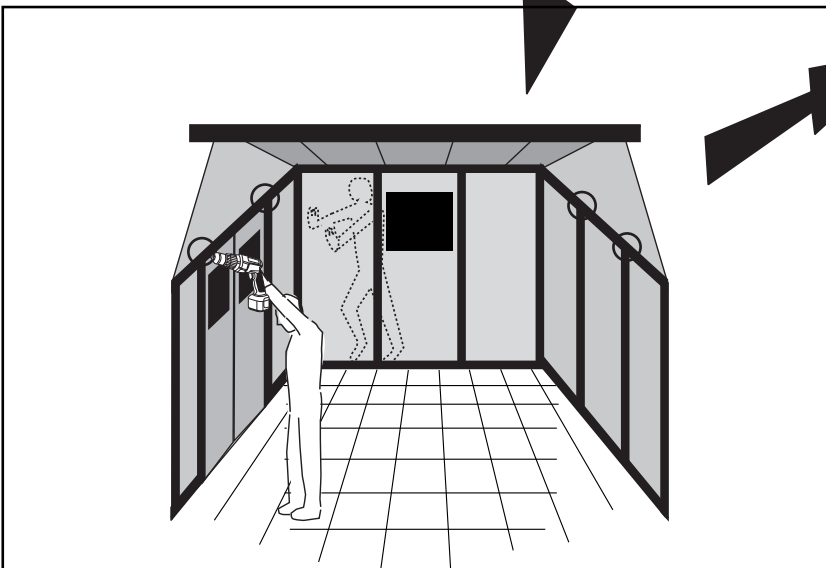
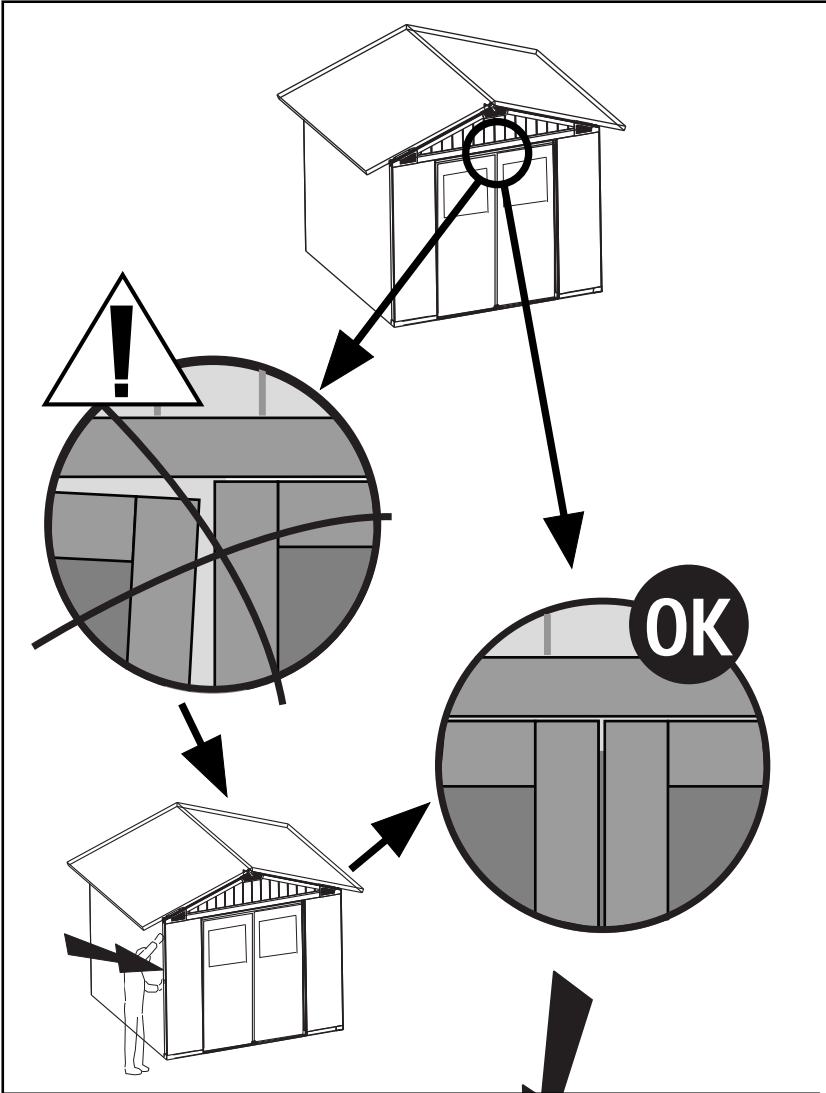
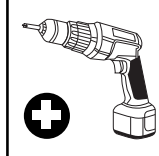
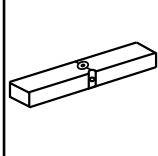

5.3

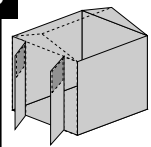

V11- SH02 (x60)
M03 (x10)

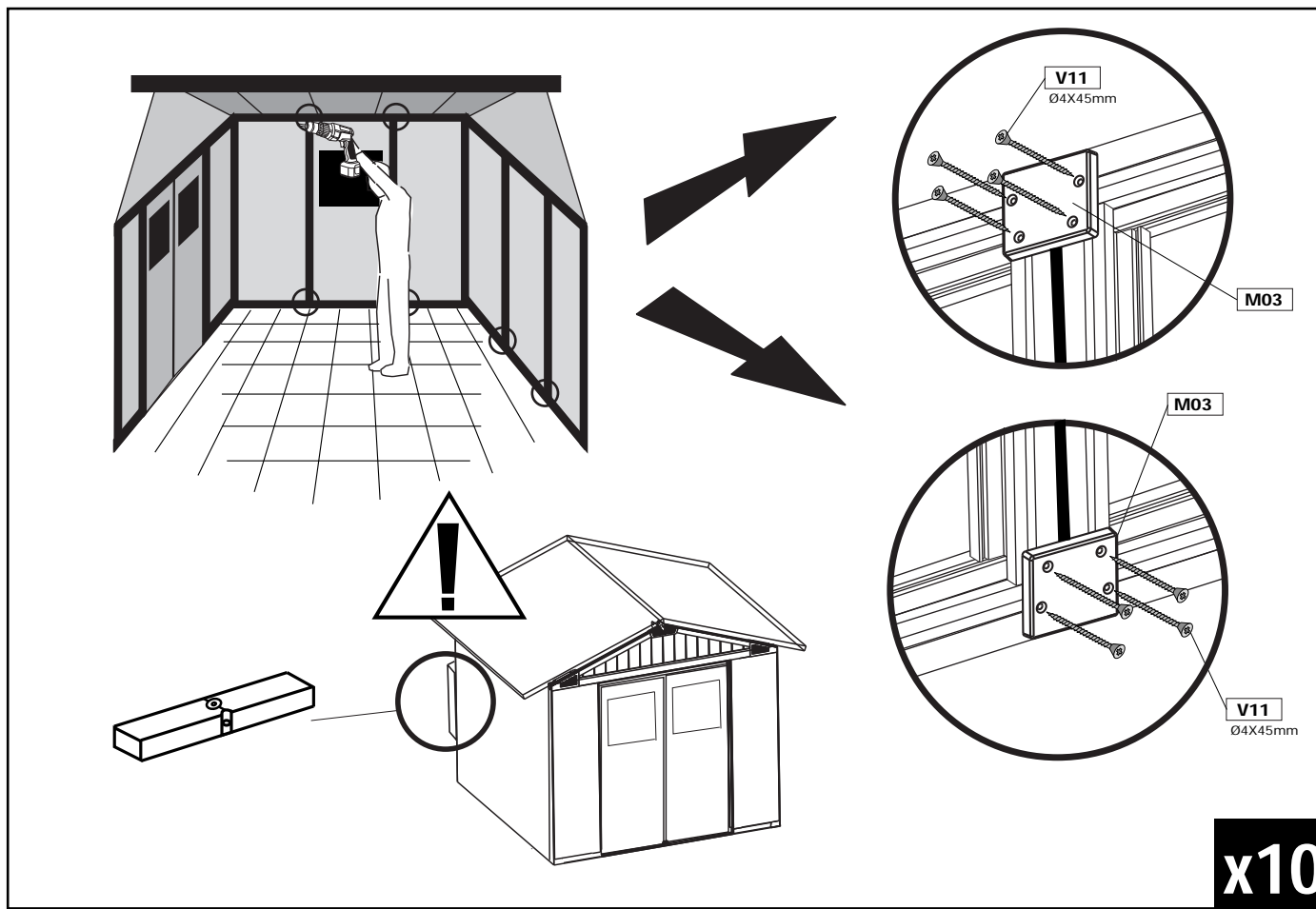
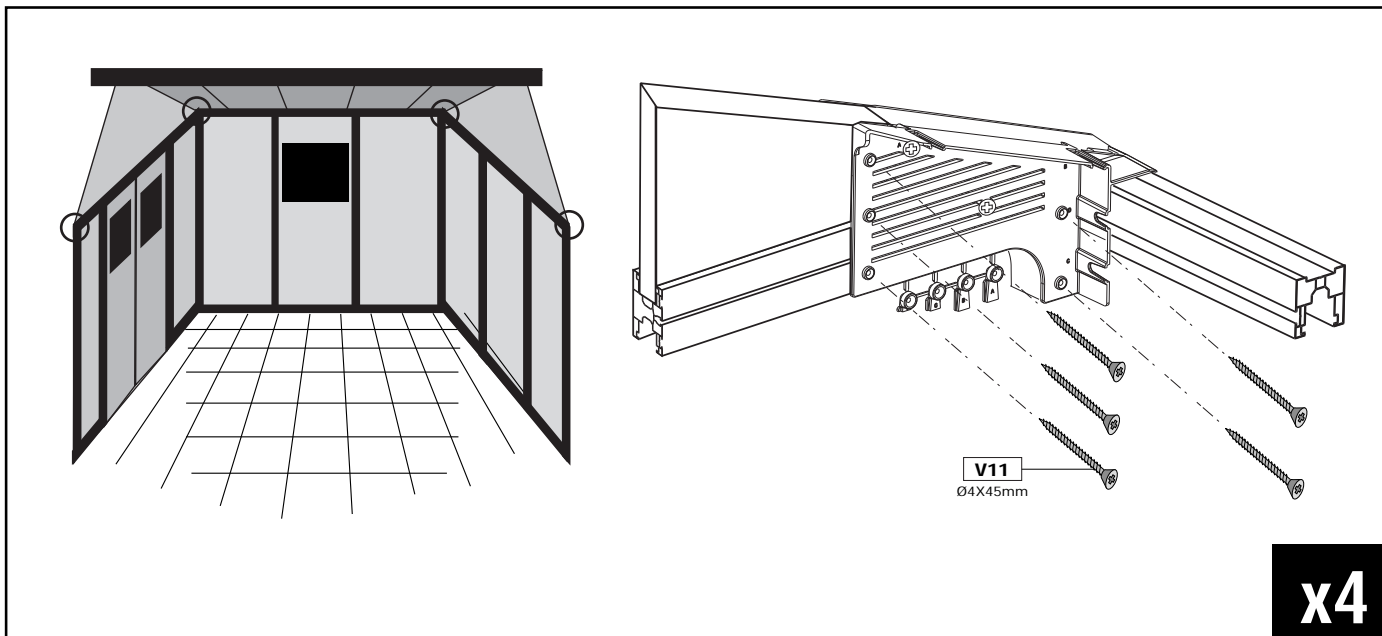
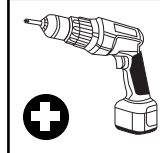
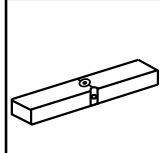

5.4

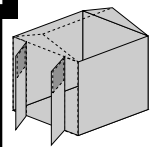

M03 (x4)
V11- SH02 (x16)

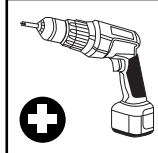

1

2

3

4

V11
Ø4x45mm

M03

x4

5.5

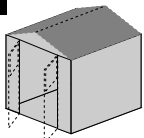

M8A (x24)

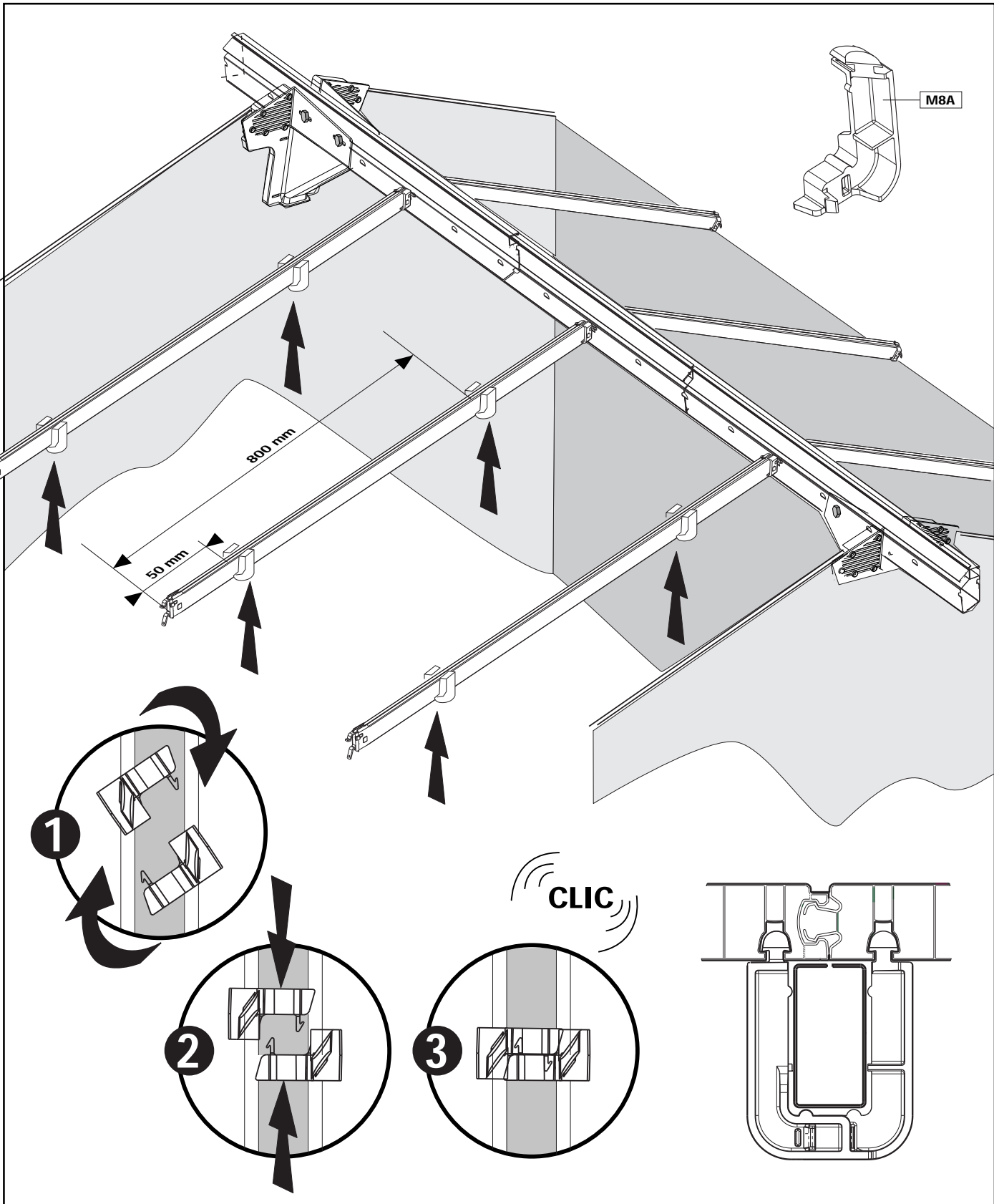
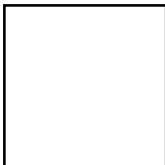

5.6

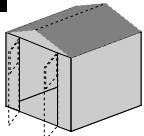

M8B (x8)
V13-SH03 (x8)

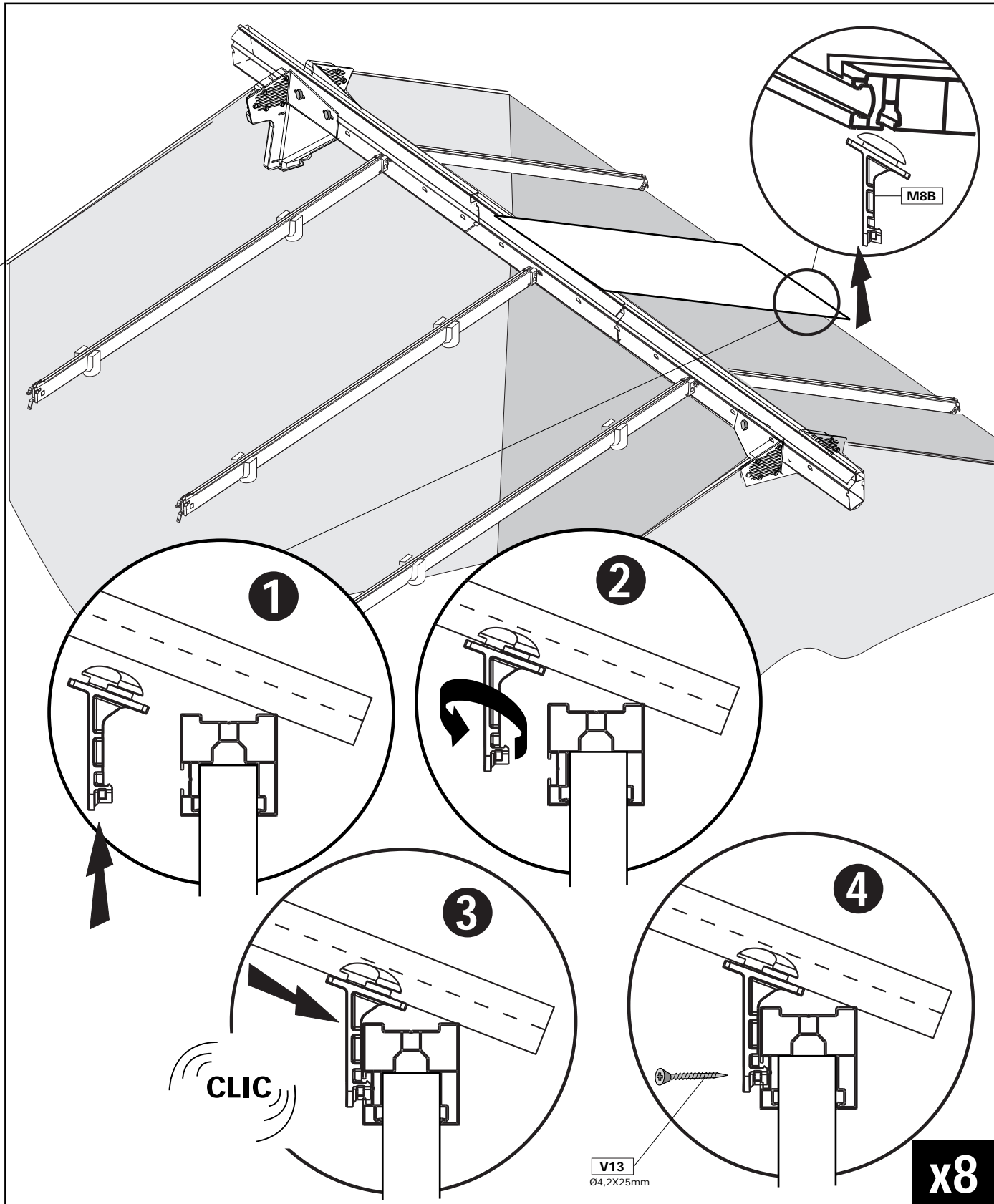

5.7

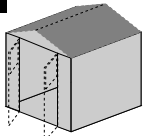

V11- SH02 (x4)
V16- SH05 (x6)

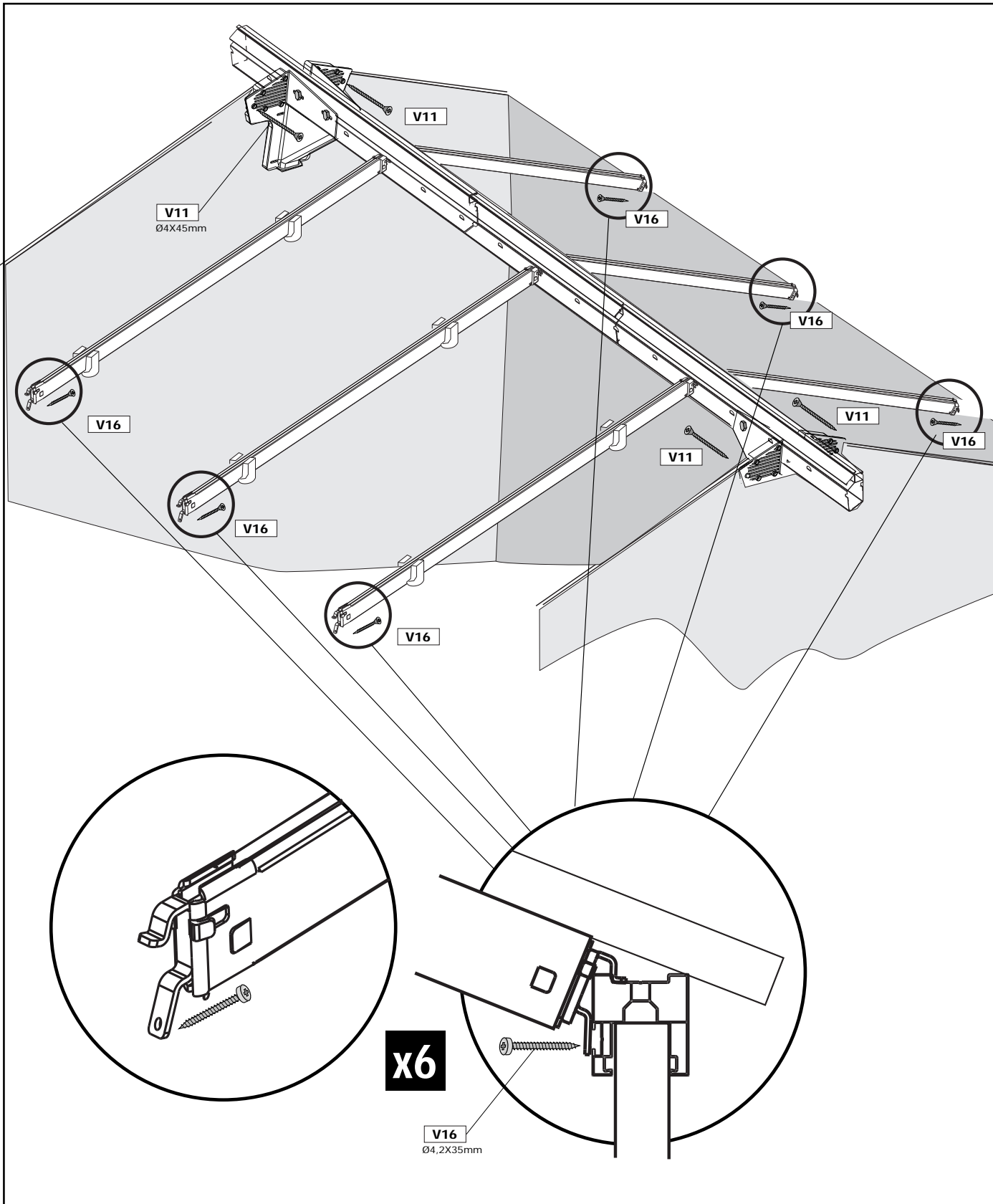

5.8

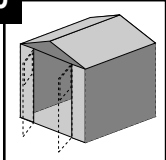

V11- SH02 (x12)

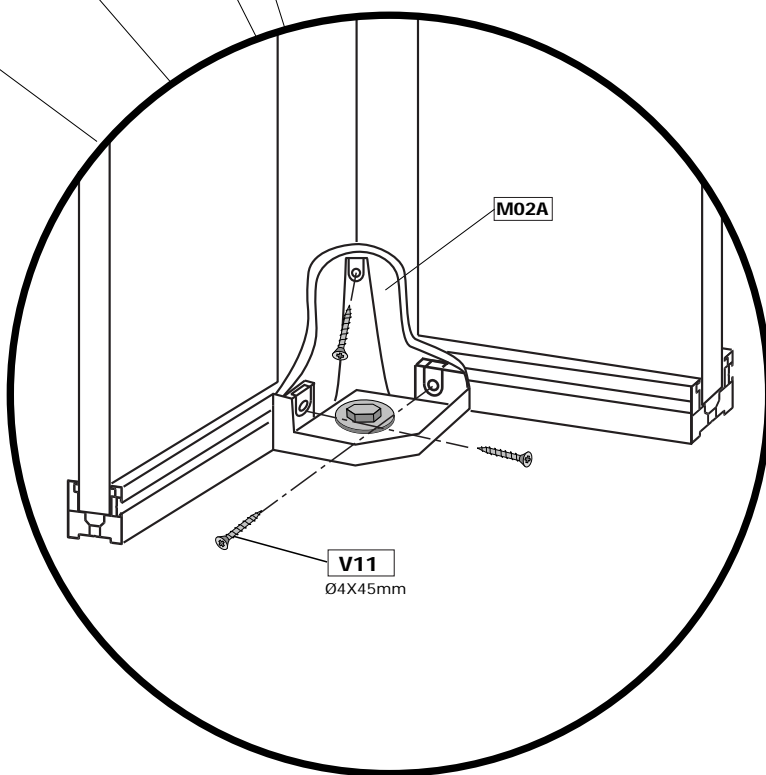
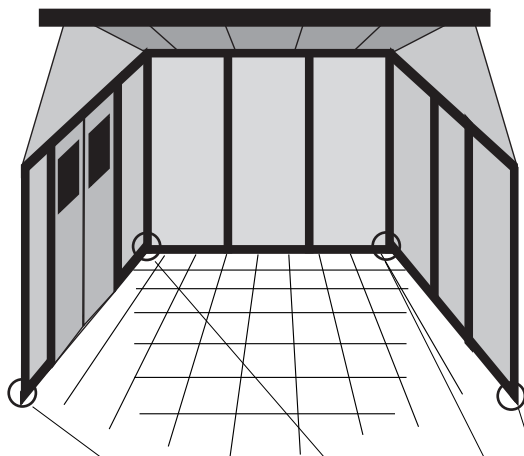
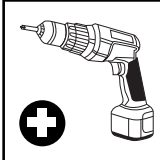



x4

6.1

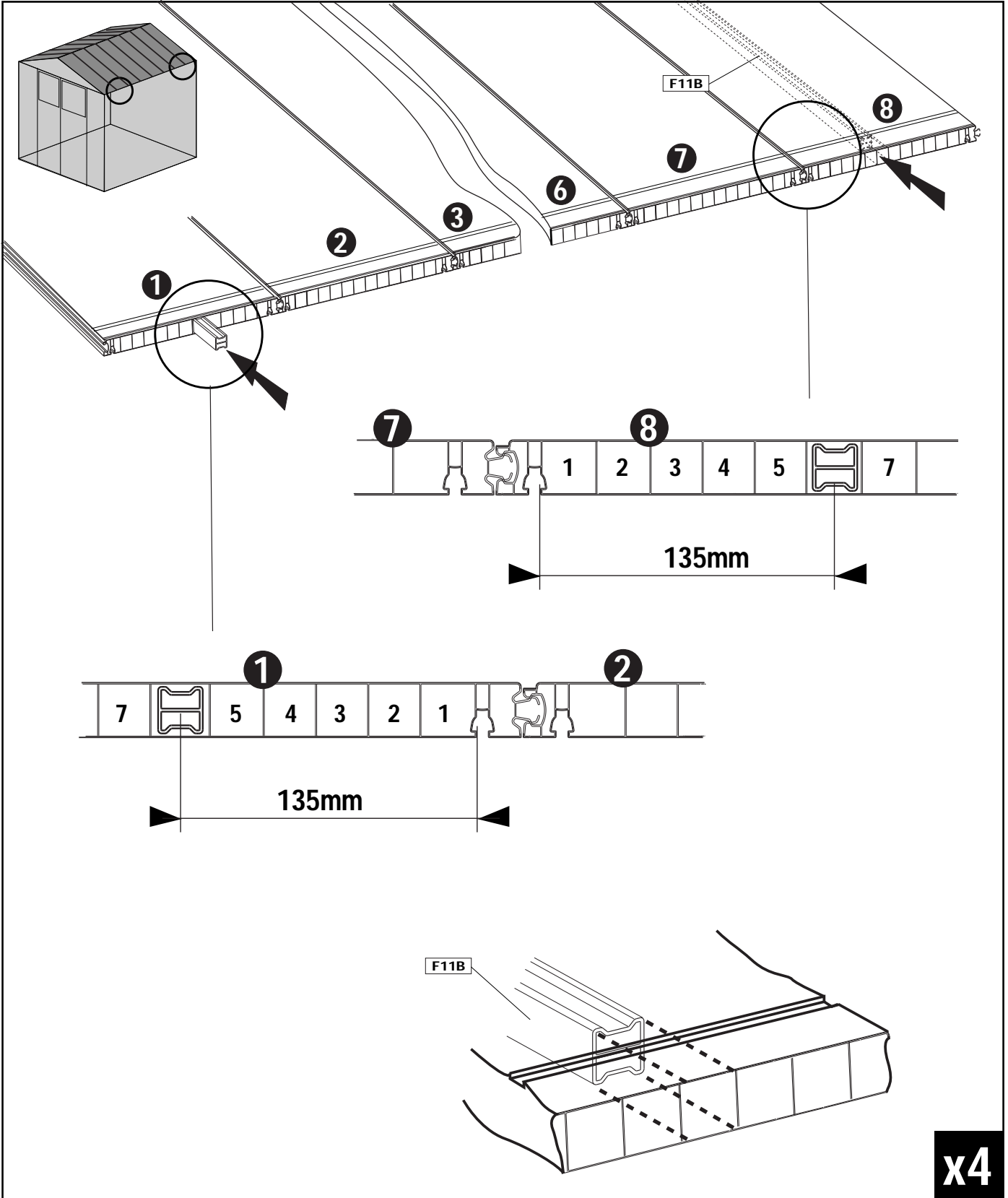
	F11B (x4)					
--	------------------	--	--	--	--	--

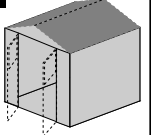

6.2

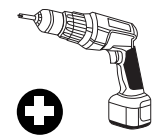
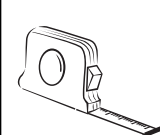
	A04 (x8) V13- SH03 (x8) V22- SH07 (x8)					
---	---	---	--	---	---	--

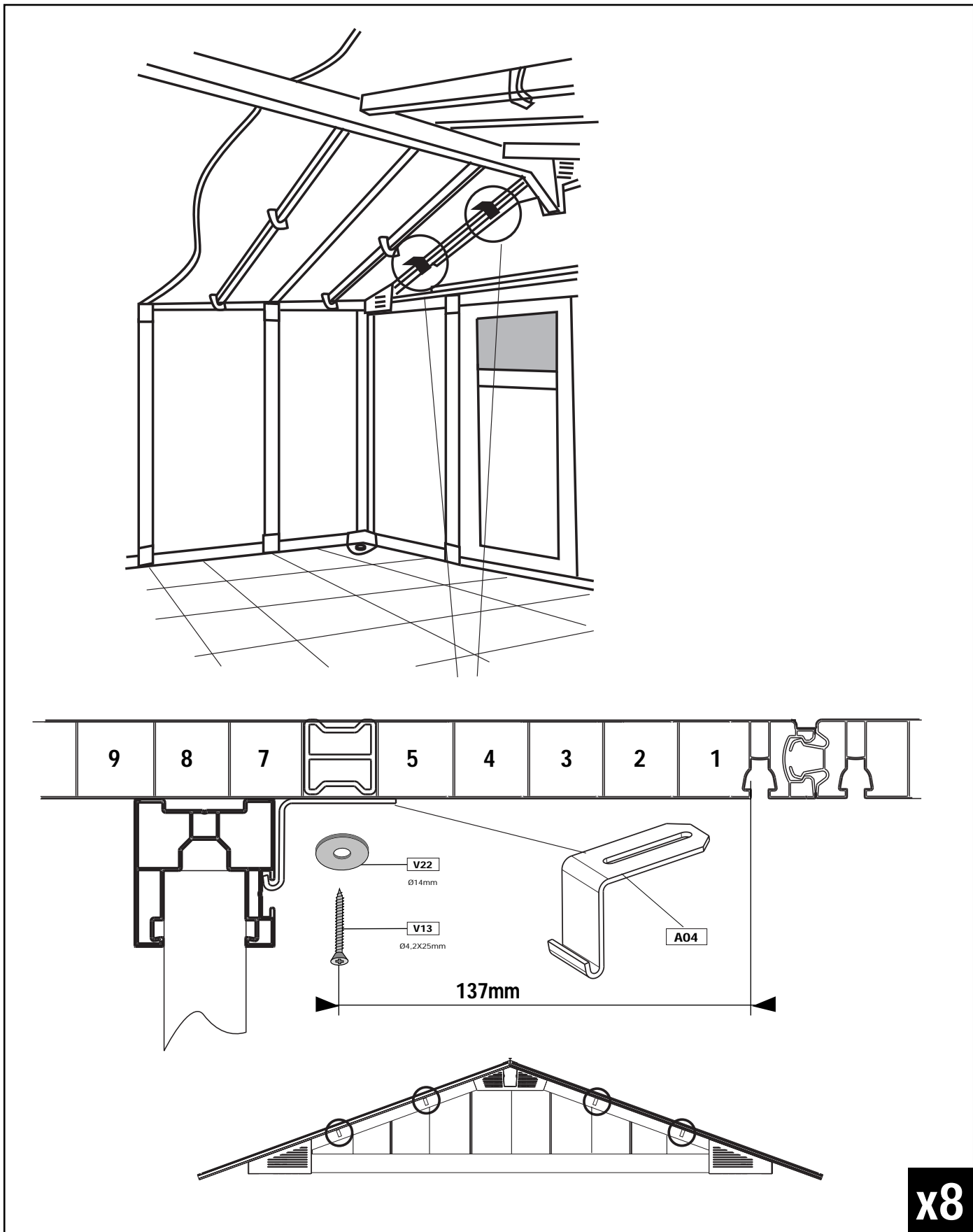

6.3

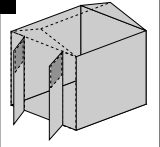

V11- SH02 (x8)
V13- SH03 (x8)

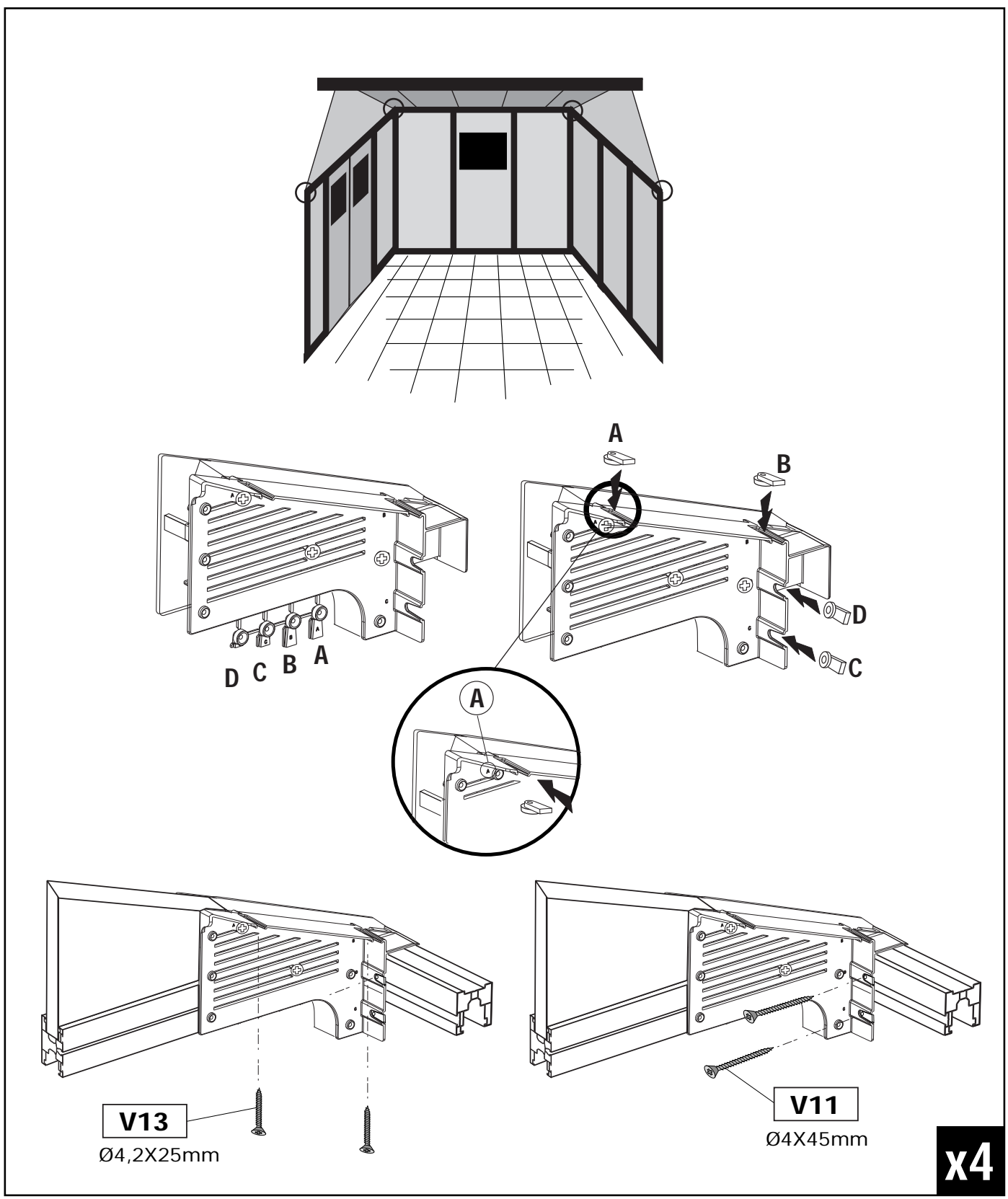
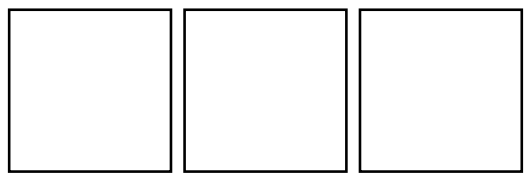
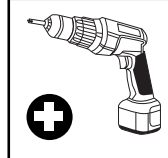

6.4

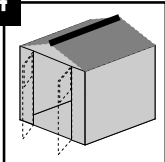

F8B (x1)
M5C (x1)

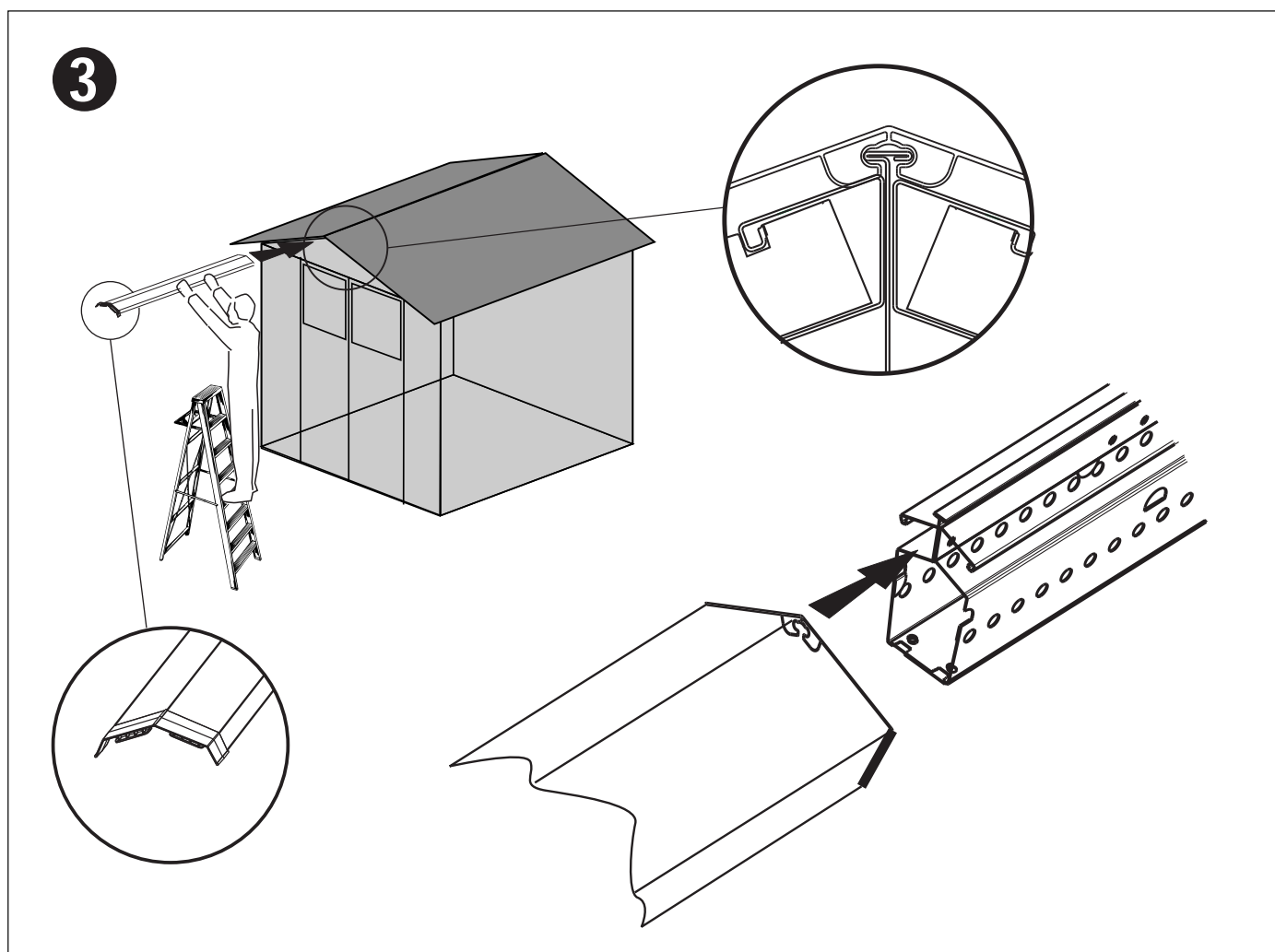
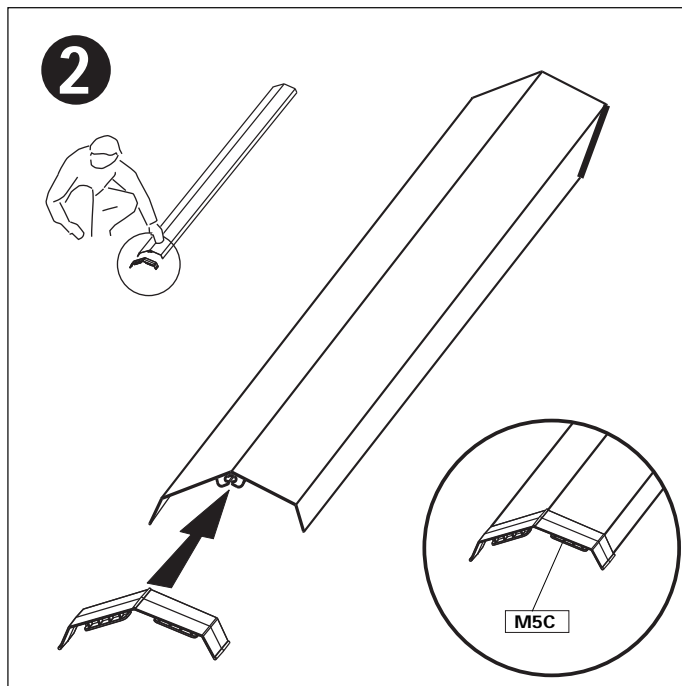
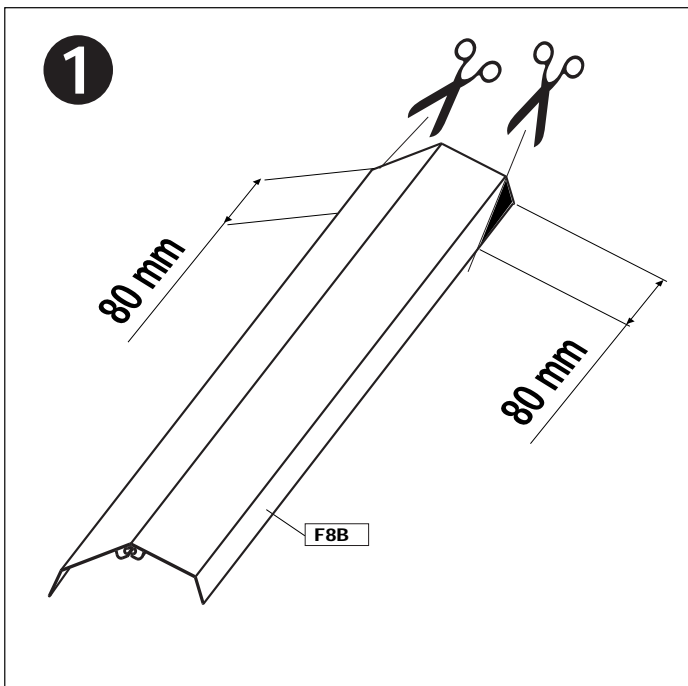
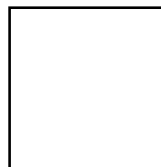

6.5

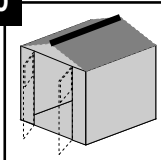

F8B (x1)

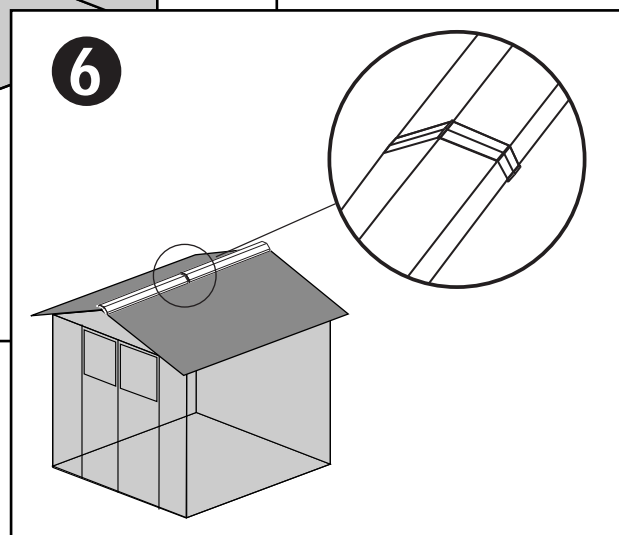
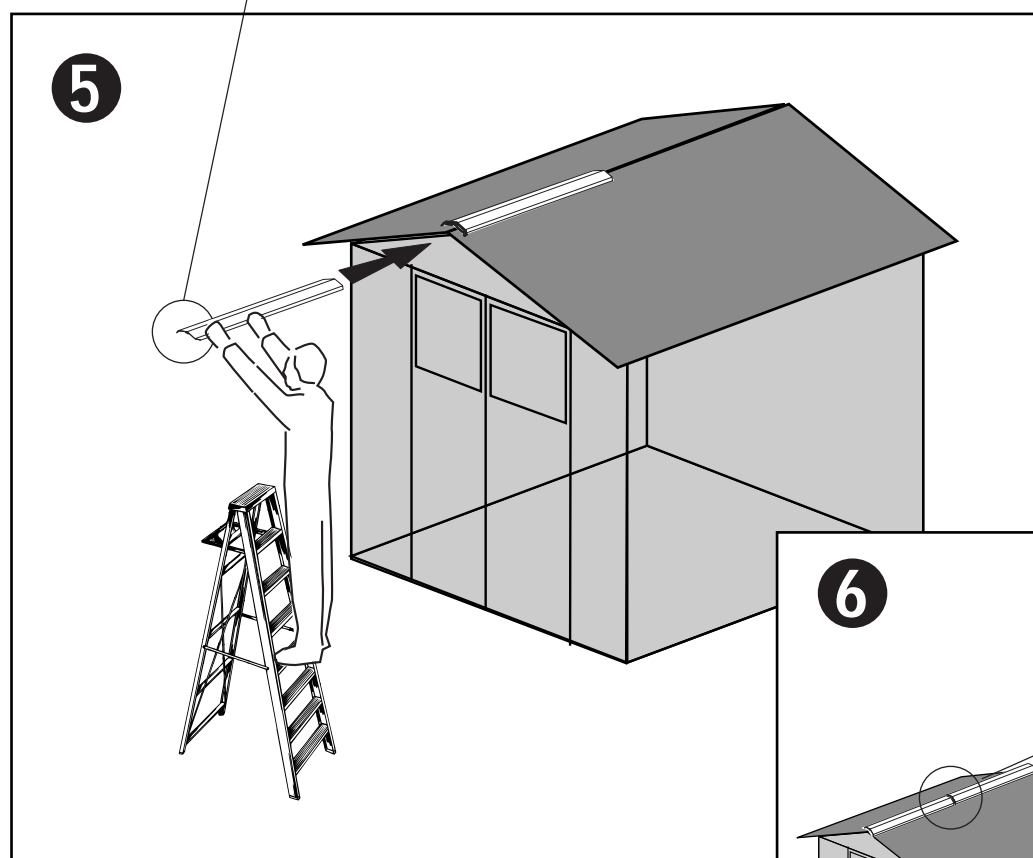
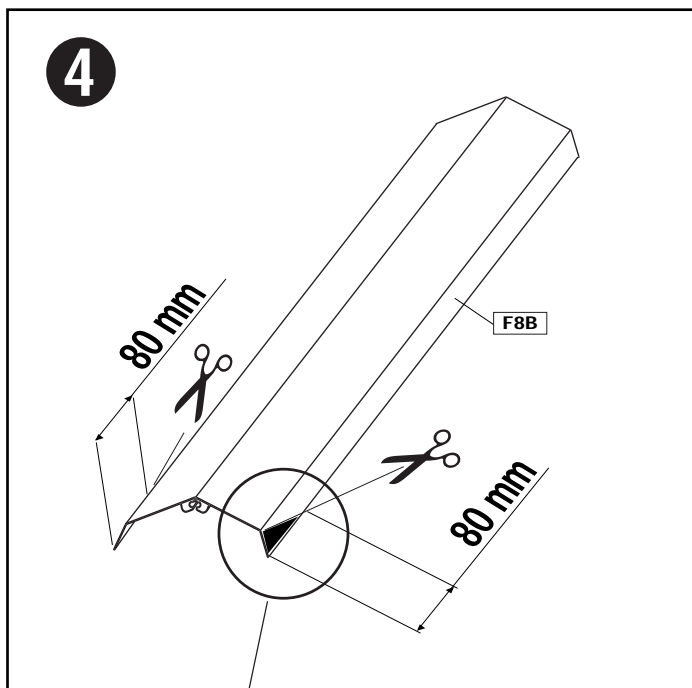
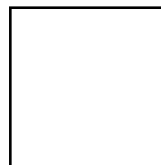

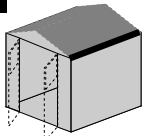

6.6

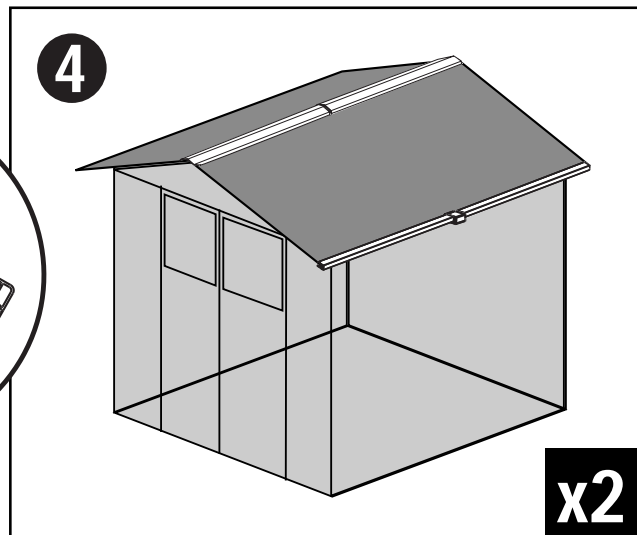
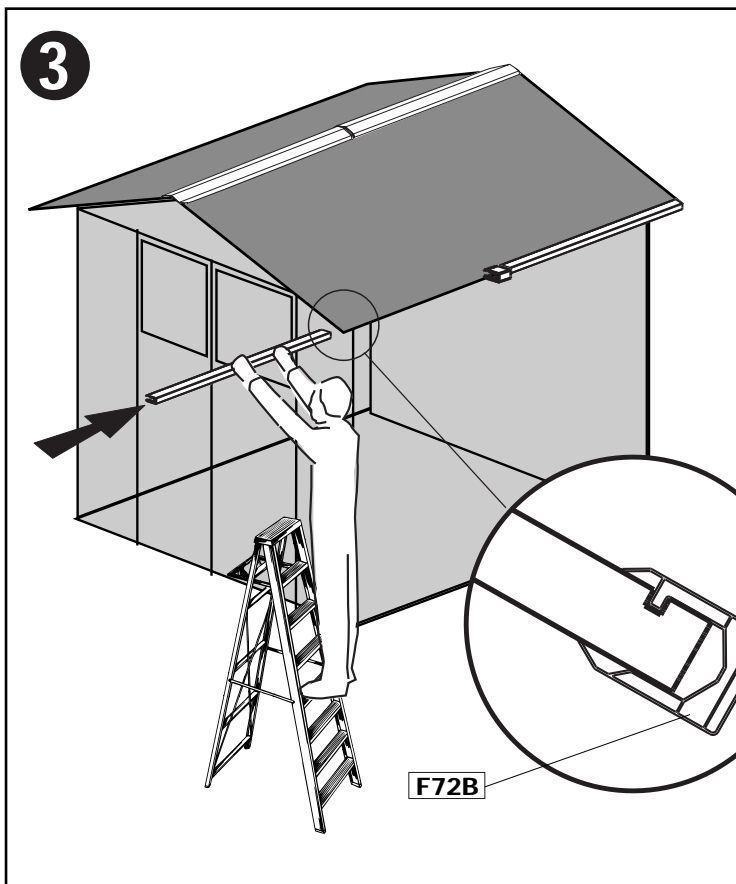
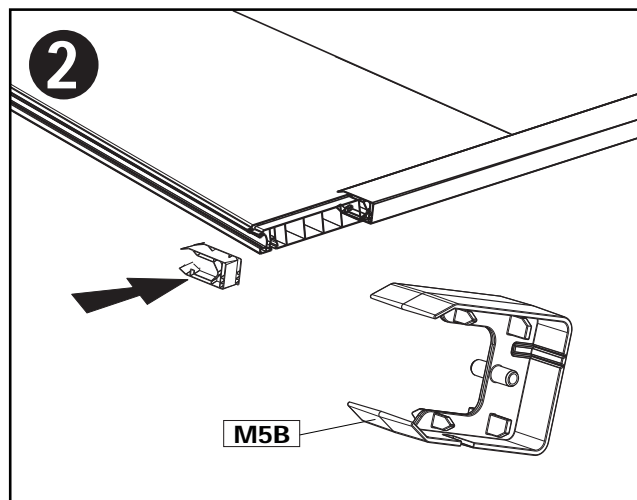
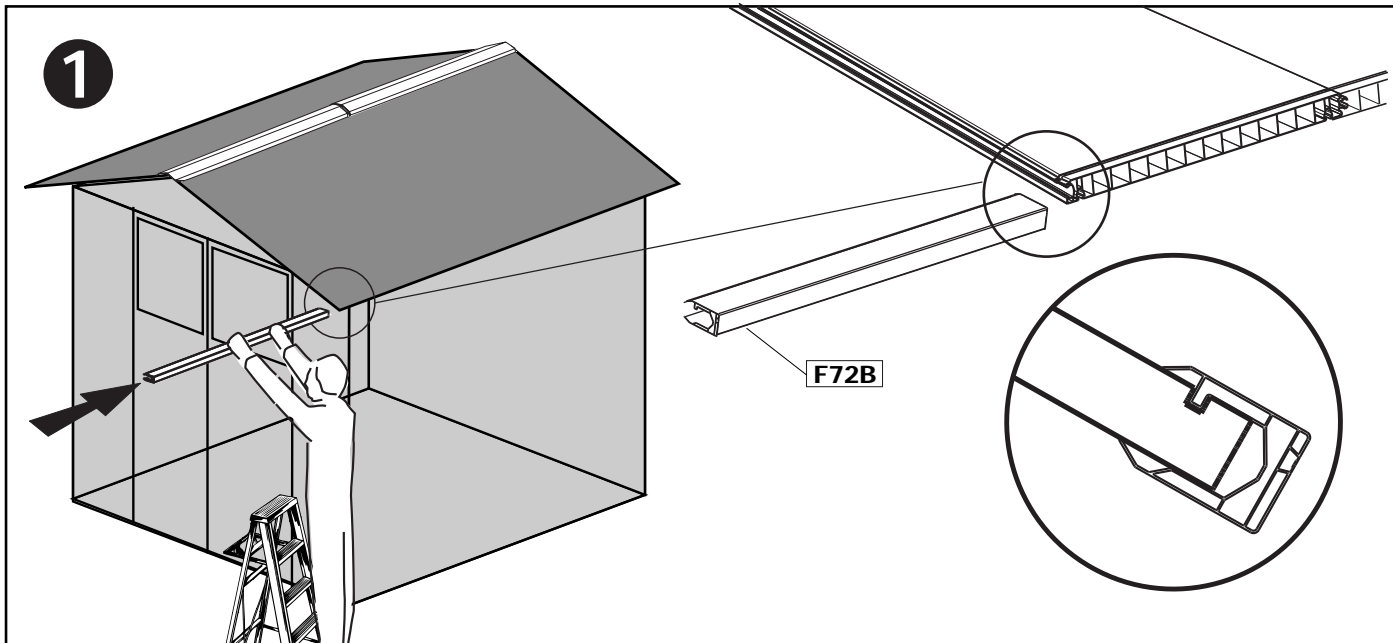

F72B (x4)
M5B (x2)

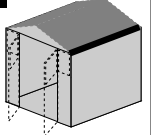

6.7

	<p>A14(x4) M5F1 (x2) M5F2 (x2)</p>					
---	--	---	--	--	--	--

5

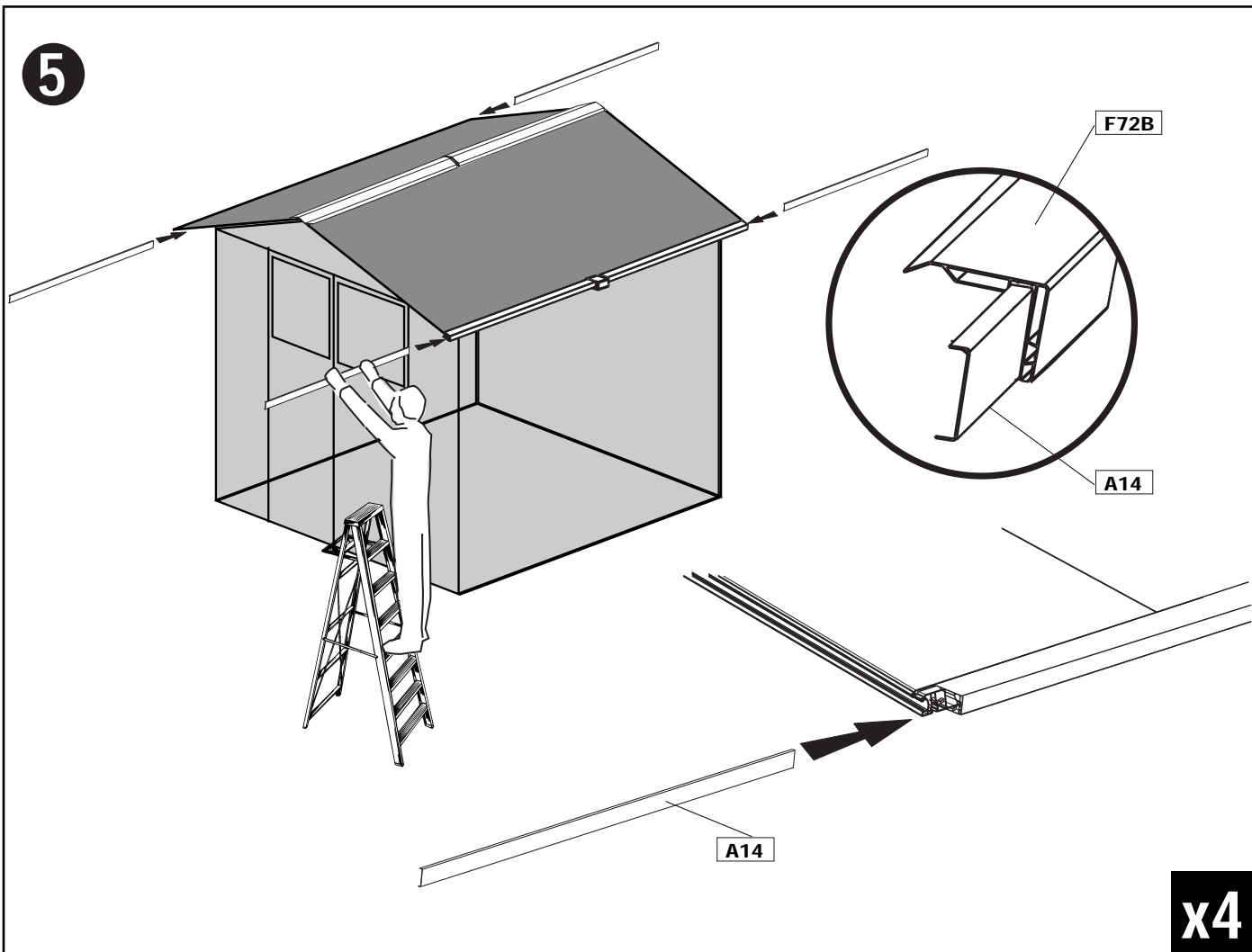

F72B

A14

A14

x4

6

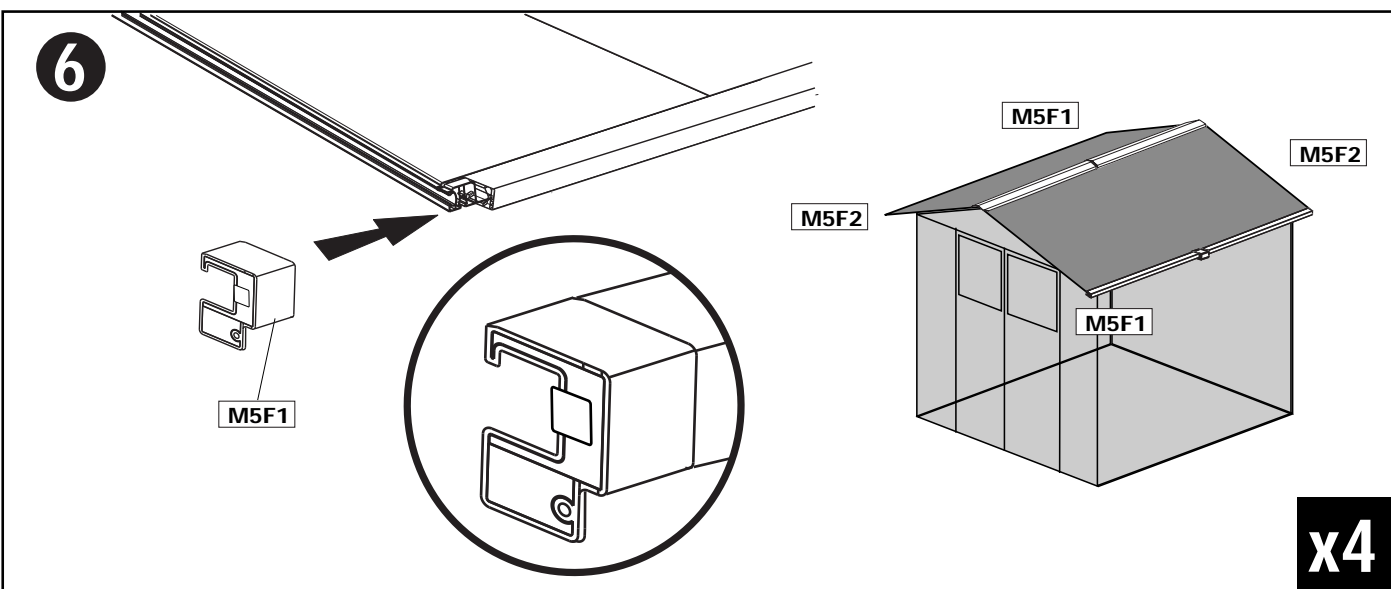

M5F1

M5F1





M5F2

M5F2

M5F1

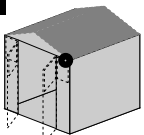
x4

6.8

	<p>F71D (x4) M5E1 (x2) M5E2 (x2) V20- SH08 (x4) M5G (x4)</p>					
---	--	---	--	---	--	--

7

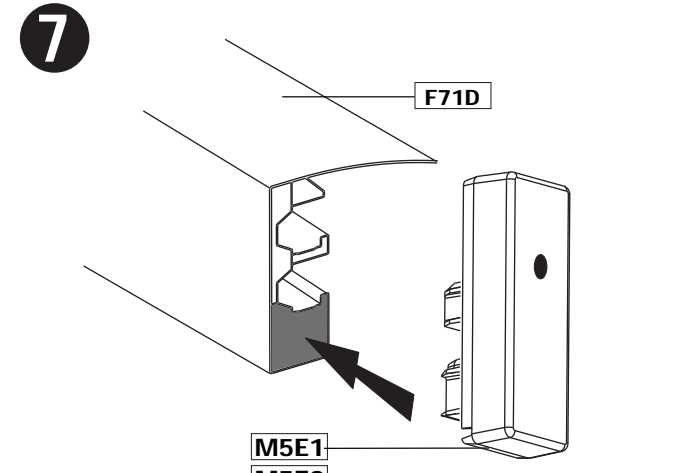

F71D

M5E1
M5E2

2+2

8

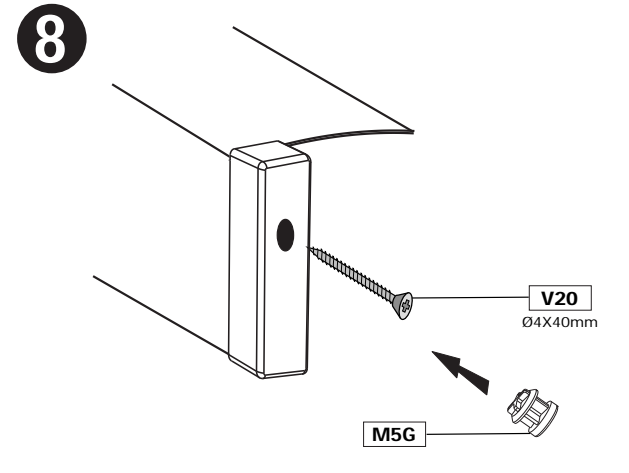

V20
Ø4X40mm

M5G

x4

9

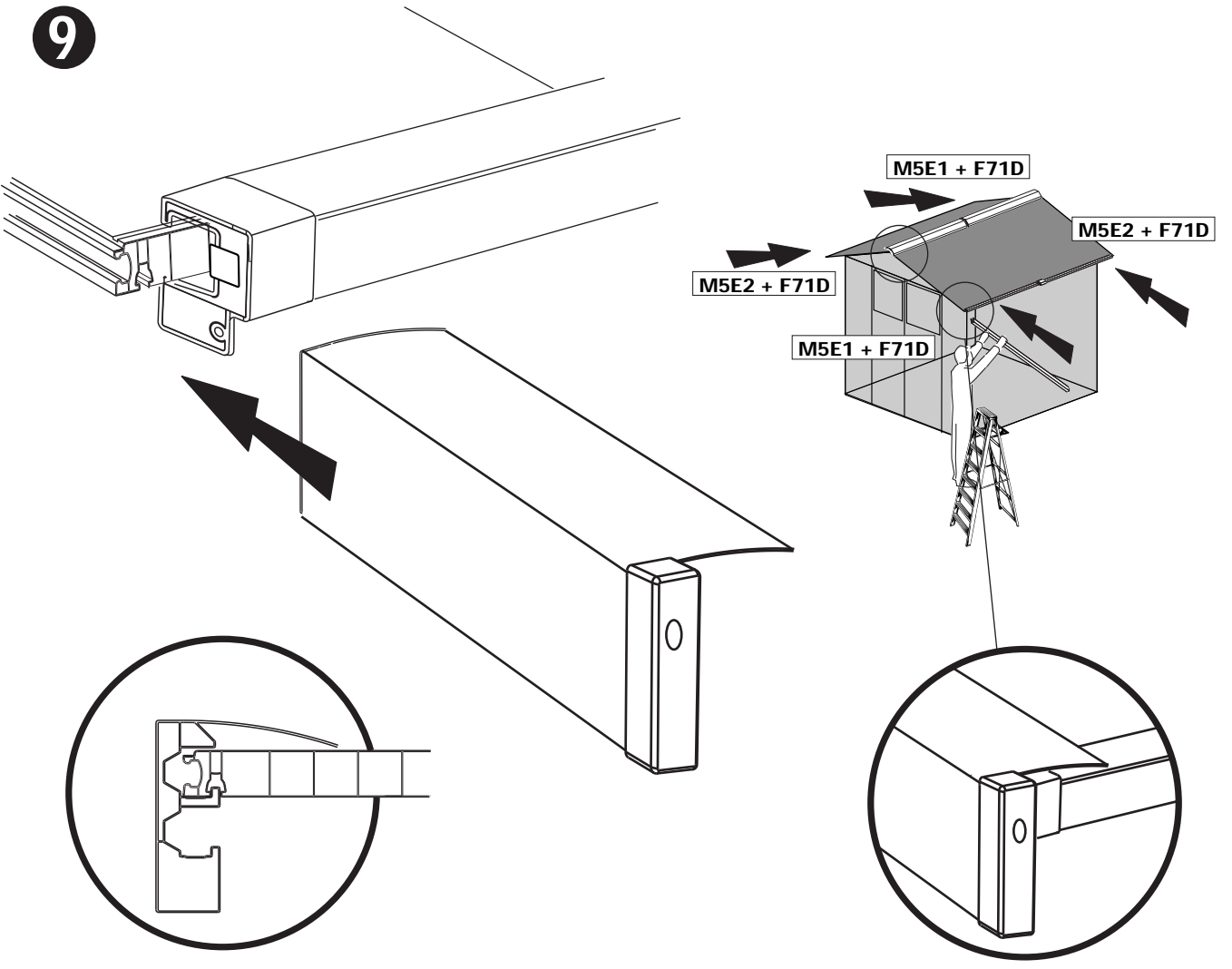

M5E1 + F71D

M5E2 + F71D

M5E2 + F71D

M5E1 + F71D

6.9

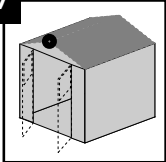

M5A (x2)
V20- SH08 (x4)
V13- SH03 (x12)

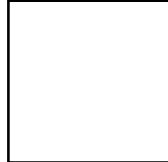
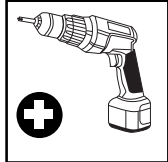

10

M5A

11

V20
Ø4X40mm

x2

12

V13
Ø4,2X25mm

V13
Ø4,2X25mm

2x4

13

V13
Ø4,2X25mm

x2



INFORMATIONS ET GARANTIE

Cher Client, Chère Cliente,

Vous venez de faire l'acquisition d'un abri de jardin Grosfillex Garden Home. Nous vous félicitons de votre choix et vous remercions de la confiance que vous nous accordez.

Nous portons, depuis plus de 50 ans, une attention particulière à la qualité de nos produits. La qualité des matériaux utilisés fait l'objet de contrôles rigoureux et sans cesse renouvelés ceci afin de vous délivrer un produit conforme à votre attente.

INFORMATIONS

L'abri de jardin dont vous venez de faire l'acquisition a été conçu en vue d'une utilisation privative. Il n'est donc en aucun cas conçu pour recevoir du public ou servir à l'exercice d'une activité commerciale.

Selon l'emplacement où elle est réalisée et selon la surface concernée, la construction de votre abri de jardin peut être soumise à une déclaration de travaux ou à une demande préalable de permis de construire. Nous vous conseillons donc de vous rapprocher de la Mairie compétente pour obtenir toutes informations utiles avant démarrage de vos travaux.

Nous attirons enfin votre attention sur certaines pratiques fortement déconseillées :

- travaux à l'aide d'une flamme nue à proximité ou à l'intérieur de l'abri,
- édification de l'abri à un emplacement fortement exposé au vent,
- défaut de fixation de l'abri au sol,
- fixation de l'abri à même le sol sans fondation,
- présence prolongée dans l'abri en cas d'exposition à une forte chaleur tout particulièrement pour les nourrissons, jeunes enfants ou personnes âgées

MODALITES DE GARANTIE

Votre abri de jardin bénéficie, comme tous les produits de notre gamme, de la garantie Grosfillex selon les modalités suivantes :

L'abri de jardin et ses composants sont garantis contre tout défaut de matière ou de fabrication pendant une durée de 10 ans et ce, à compter de la date d'achat figurant sur votre facture ou ticket de caisse.

En cas de réclamation, vous devrez impérativement rappeler le numéro de série de votre abri Garden Home ainsi que la référence de la pièce défectueuse et présenter votre justificatif d'achat (facture, ticket de caisse). Ces informations sont rappelées sur votre notice de montage ainsi que sur notre site www.grosfillex-gardenhome.com. Pensez donc à conserver précieusement votre justificatif d'achat et votre notice de montage.

Dans le cas du remplacement d'une pièce manquante ou défectueuse couverte par la garantie, Grosfillex s'engage à vous délivrer, sans frais, ladite pièce dans les plus brefs délais. Dans le cas où une pièce couverte par la garantie n'est plus disponible, Grosfillex la remplacera par une pièce adaptable et de qualité identique.

En cas de problème sur votre abri Garden Home, nous vous prions de contacter notre service consommateurs via notre site Internet (www.grosfillex-gardenhome.com) ou par courrier, à l'adresse suivante :

GROSFILLEX S.A.S.
S.A.V. Garden Home
Arbent
01100 OYONNAX
FRANCE

Nous répondrons dans les plus brefs délais à votre réclamation.

EXCLUSIONS DE GARANTIE

Nous vous informons que notre garantie est par contre exclue dans les cas suivants :

- modification ou altération du produit par le client,
- non-respect des préconisations de montage, d'utilisation ou d'entretien,
- utilisation de pièces ou de composants non fournis par Grosfillex,
- usage excessif de la force lors de l'assemblage des composants,
- altération du PVC due à l'émanation de produits chimiques entreposés dans l'abri,
- déformation de l'abri due à l'entreposage d'objets lourds contre les parois,
- fixation de crochets, de vis, de supports ou de systèmes de suspension autres que ceux fournis ou préconisés par Grosfillex,
- décoloration progressive du PVC due à l'exposition aux rayons solaires,
- usure liée à l'utilisation et/ou au vieillissement normal du produit,
- usage de produits abrasifs ou de détergents pour nettoyer votre abri Garden Home,
- déformation due à l'absence de fondations ou à des fondations défectueuses,
- dégâts provoqués par des aléas climatiques exceptionnels (tempêtes, ouragans, foudre, inondations),
- chocs causés par des projectiles.



HINWEISE UND GARANTIELEISTUNG

Liebe Kundin, lieber Kunde,

Sie haben soeben ein Garden Home Gartenhaus von Grosfillex erworben. Wir beglückwünschen Sie zu Ihrer Wahl und bedanken uns bei Ihnen für das Vertrauen, das Sie uns entgegengebracht haben.

Seit über 50 Jahren legen wir besonderen Wert auf die Qualität unserer Produkte. Die Qualität der verwendeten Materialien unterliegt strengen Kontrollen, die in regelmäßigen Abständen wiederholt werden, damit das gelieferte Produkt stets Ihren Anforderungen entspricht.

INFORMATIONEN

Das von Ihnen erworbene Gartenhaus wurde für privaten Gebrauch entwickelt. Es ist somit auf keinen Fall für den Publikumsverkehr oder für die Ausübung einer kommerziellen Tätigkeit geeignet.

Je nach Standort und betroffener Standfläche kann der Bau Ihres Gartenhauses von einer entsprechenden Bauerkklärung oder einem vorherigen Baugenehmigungsantrag abhängen. Wir empfehlen Ihnen somit, sich an Ihr zuständiges Bürgermeisteramt zu wenden und dort die erforderlichen Informationen einzuholen, bevor Sie mit den Arbeiten beginnen.

Wir lenken ferner Ihre Aufmerksamkeit auf bestimmte Praktiken, von denen wir Ihnen strengstens abraten:

- nicht mit einer offenen Flamme in der Nähe oder im Inneren des Gartenhauses arbeiten
- das Gartenhaus nicht dort aufstellen, wo es starken Winden ausgesetzt wird
- Fehler bei der Befestigung des Gartenhauses am Boden vermeiden
- die Installation des Gartenhauses ohne Fundament ist untersagt. Auch werden in einem solchen Fall sämtliche Garantieansprüche abgelehnt
- bei starker Sonneneinstrahlung und Wärme einen längeren Aufenthalt im Gartenhaus vermeiden; dies gilt insbesondere für Säuglinge, Kleinkinder und ältere Menschen.

GARANTIEBEDINGUNGEN

Wie alle Produkte unserer Produktpalette verfügt Ihr Gartenhaus über eine Grosfillex-Garantie mit folgenden Modalitäten:

Ab dem auf Ihrer Originalrechnung / Ihrem Kassenbeleg angegebenen Kaufdatum gewähren wir eine 10 jährige Garantie auf Material- und Fertigungsfehler.

Im Falle einer Reklamation sind die Vorlage der Rechnung / des Kassenbeleges, sowie die Angabe der Seriennummer sowie der Teilenummer des reklamierten Einzelteils notwendig. Diese Informationen finden Sie in Ihrer Aufbauanleitung und auf unserer Website <http://www.grosfillex-gardenhome.com/>.

Im berechtigten Reklamationsfall erhalten Sie kostenlos das benötigte Ersatzteil. Sollte ein entsprechendes Ersatzteil nicht erhältlich sein, bietet Ihnen Grosfillex ein ähnliches Teil gleicher Qualität an, das angepasst werden kann.

Sollten Sie weitere Probleme mit Ihrem Gartenhaus haben, sehen Sie nach Abhilfe auf unserer Website <http://www.grosfillex-gardenhome.com> nach, oder wenden Sie sich schriftlich an unseren Kundendienst.

Die Adresse lautet:

GROSFILLEX GMBH
Oststrasse 77
D-56235 RANSBACH-BAUMBACH

Wir werden so schnell wie möglich auf Ihr Reklamations Schreiben antworten.

GARANTIEAUSSCHLUSS:

Wir weisen darauf hin, dass unsere Garantie folgende Fälle nicht deckt:

- Abänderung des Produkts durch den Kunden
- Nichtbeachtung der Montage-, Gebrauchs- und Wartungsempfehlungen
- Verwendung von Teilen bzw. Einzelteilen, die nicht von Grosfillex geliefert wurden
- übermäßige Kräfteanwendung beim Zusammenbauen des Gartenhauses
- Beschädigung des Materials durch die Auströmung von chemischen Substanzen, die im Gartenhaus gelagert sind
- Verformung des Gartenhauses durch schwere Gegenstände, die an die Wand des Gartenhauses gelehnt wurden
- Befestigung von Haken, Schrauben, Trägern oder Aufhängesystemen, die nicht von Grosfillex geliefert bzw. empfohlen wurden
- allmähliches Verbleichen des Materials durch die Sonneneinstrahlung
- Abnutzung aufgrund eines normalen Gebrauchs und/oder normalen Alterung des Produkts
- Beschädigungen durch den Einsatz von Scheuermitteln oder nicht empfohlenen Waschmitteln für die Reinigung Ihres Gartenhauses Garden Home
- Verformung aufgrund von fehlenden oder defekten Fundamenten,
- Beschädigungen, die durch außergewöhnliche klimatische Verhältnisse verursacht wurden (Sturm, Orkan, Blitz, Überschwemmungen)
- Beschädigungen durch Geschosse



INFORMATION AND GUARATEE

Dear Customer,

You have just bought a Grosfillex Garden Home. Congratulations on your choice and thank you for the confidence that you have shown in us. We have been paying special attention to the quality of our products for more than 50 years. The quality of the materials used is subject to rigorous checks and is continuously renewed in order to give you the product that meets your expectations.

INFORMATION

The garden shed that you have just bought was designed to be used privately. It has not therefore been designed under any circumstances for a public event or for the exercise of a commercial activity. Depending on the location and the surface in question, the construction of your garden shed may require a work declaration or a prior request for planning permission. We therefore advise you to contact the relevant local authority to obtain all the necessary information before starting your work. Finally, we would like to draw your attention to certain practices that we strongly advise you not to follow:

- working using a naked flame close to or inside the shed,
- building the shed in a location which is very exposed to the wind,
- a fault in attaching the shed to the ground,
- attaching the shed to the bare ground without foundations,
- prolonged presence in the shed in the case of exposure to high levels of heat, especially for infants, young children or the elderly.

GUARANTEE CONDITIONS

Like all products in our range, your garden shed benefits from the Grosfillex guarantee as follows: The garden shed and its components are guaranteed against any material or manufacturing fault for 10 years as of the date of purchase which appears on your invoice or till receipt. Should you wish to make a claim, you must quote the serial number of your Garden House and the reference of the faulty parts and present your purchase documents (invoice, till receipt). This information is quoted in your assembly instructions and on our website (<http://www.grosfillex-gardenhome.com/>). Therefore please keep your purchase document and your assembly instructions safe. Should a missing or faulty part covered by the guarantee be replaced, Grosfillex agrees to deliver it to you as soon as possible free of charge. Should a part covered by the guarantee not be available, Grosfillex will replace it with an adaptable part of an identical quality. Should a problem arise with your Garden Home, please contact the Customer Relations Department via our website (www.grosfillex-gardenhome.com) or by post at the following address:

GROSFILLEX S.A.S.
S.A.V. Garden Home
Arbent
01100 OYONNAX
FRANCE

We will reply to your claim as soon as possible.

EXCLUDED FROM THE GUARANTEE

We wish to inform you that our guarantee will not cover the following cases:

- modification or alteration of the product by the client,
- non-compliance with the assembly, use or maintenance recommendations,
- use of parts or components not supplied by Grosfillex,
- excessive use of force when assembling the components,
- alteration of the PVC caused by the emanations of chemical products stored in the shed,
- deformation of the shed caused by the storage of heavy objects against the wall,
- attachment of hooks, screws, supports or suspension systems other than those supplied or recommended by Grosfillex,
- progressive decolouring of the PVC due to exposure to the sun's rays,
- wear and tear linked to the use and/or normal ageing of the product,
- use of abrasive products or detergents to clean your Garden Home,
- deformation due to the absence of foundations or faulty foundations,
- damage caused by exceptional climatic hazards (storms, hurricanes, lightning, floods),
- impacts caused by projectiles.



INFORMAZIONI E GARANZIA

Caro Cliente, Ha appena acquistato una Home Garden Grosfillex. Congratulazioni per la sua scelta. La ringraziamo per la fiducia espressa nei nostri confronti.

Da più di 50 anni fabbrichiamo i nostri prodotti con una particolare attenzione alla qualità. I materiali usati sono controllati rigorosamente e vengono continuamente rinnovati per consegnare prodotti conformi alle aspettative del nostro pubblico.

INFORMAZIONI

La casetta che ha appena acquistato è stata ideata per un uso privato e non per ricevere pubblico o praticare un'attività commerciale. In base alla posizione e alla superficie, la costruzione dovrà rispettare le dichiarazioni relative ai lavori o alle richieste di permessi. Le consigliamo di rivolgersi al Comune per ottenere tutte le informazioni utili prima di iniziare i lavori. E le chiediamo di prestare attenzione ad alcune pratiche fortemente sconsigliate:

- fiamma nuda vicino o all'interno della casa,
- zone esposte al vento,
- difetti di fissaggio,
- fissaggio senza fondamenta,
- permanenza prolungata con temperature alte – soprattutto per neonati, bambini o anziani

MODALITÀ DI GARANZIA

La Home Garden, come tutti i prodotti della nostra gamma, è garantita Grosfillex in base alle seguenti modalità: la casetta e i componenti sono garantiti contro difetti di materiali o fabbricazione per 10 anni a partire dalla data di acquisto riportata sullo scontrino. In caso di reclami, sarà necessario fornire il numero di serie del prodotto e il codice del pezzo difettoso e presentare lo scontrino o la fattura dell'acquisto. Queste informazioni sono scritte sulle istruzioni e sul nostro sito www.grosfillex-gardenhome.com. Conservare quindi lo scontrino e le istruzioni. Nel sostituire un pezzo mancante o difettoso coperto dalla garanzia, Grosfillex si impegna a consegnarlo gratuitamente il prima possibile. Se il pezzo coperto dalla garanzia non fosse più disponibile, Grosfillex lo sostituirà con un pezzo adattabile e della stessa qualità. Per qualsiasi problema incontrato con la Garden Home, la invitiamo a contattare il servizio clienti tramite il sito Internet (www.grosfillex-gardenhome.com) o per posta all'indirizzo seguente:

GROSFILLEX Spa
Servizio Dopo Vendita Garden Home
Via vercelli,5
13030 CARESANABLOT (VC)
ITALIA

Risponderemo il prima possibile ad ogni reclamo.

ESCLUSIONI DI GARANZIA

La informiamo che la garanzia non copre i seguenti casi:

- prodotto modificato o alterato dal cliente,
- mancato rispetto delle istruzioni di montaggio, uso o manutenzione,
- uso di pezzi o elementi non forniti da Grosfillex,
- uso eccessivo di forza nell'assemblare i pezzi,
- alterazione del PVC dovuta all'emissione di prodotti chimici posti nella casa,
- deformazione del rifugio dovuta a oggetti pesanti contro le pareti
- fissaggio di ganci, viti, supporti o sistemi a sospensione diversi da quelli forniti o previsti da Grosfillex,
- scolorimento progressivo del PVC dovuto all'esposizione ai raggi del sole
- usura dovuta all'uso e/o all'invecchiamento normale del prodotto,
- uso di prodotti abrasivi o di detergenti per pulire la Garden Home,
- deformazione dovuta all'assenza di fondamenta o a fondamenta difettose,
- danni provocati da fattori climatici eccezionali (bufere, uragani, fulmini, alluvioni),
- scontri con oggetti lanciati e proiettili



INFORMACIÓN Y GARANTÍA

Estimado Cliente, Estimada Cliente,

Acaba de adquirir un cobertizo de jardín Grosfillex "Garden Home". Le felicitamos por su elección y le damos las gracias por la confianza que nos manifiesta.

Desde hace más de 50 años, prestamos una atención especial a la calidad de nuestros productos. La calidad de los materiales utilizados se somete a rigurosos controles sin cesar renovados, esto con el fin de entregarles un producto conforme a sus expectativas.

INFORMACIONES

El cobertizo de jardín que acaba de comprar, se ha concebido con vistas a una utilización privada. No se ha pensado, de modo alguno, para recibir público o ejercer una actividad comercial. Según el emplazamiento en el que se realice y según la superficie concernida, la construcción del cobertizo de jardín, puede estar sujeta a una declaración de obras o a una solicitud previa de licencia de obras. Así pues, le aconsejamos vaya al Ayuntamiento competente para que le informen debidamente antes de comenzar a montarlo. Por último, deseamos llamar su atención sobre algunas prácticas muy desaconsejadas:

- trabajos con una llama desnuda a proximidad o dentro del cobertizo,
- edificación del cobertizo en un emplazamiento muy expuesto al viento,
- Fallo de fijación del cobertizo en el suelo,
- Fijación del cobertizo a nivel del suelo sin cimiento,
- permanecer mucho tiempo en el cobertizo, en caso de que hiciese mucho calor, particularmente para los bebés, niños pequeños o personas mayores.

GARANTÍA MODALIDADES

El cobertizo de jardín se beneficia, al igual que los productos de nuestra gama, de la garantía Grosfillex según las siguientes modalidades. El cobertizo de jardín y sus componentes están garantizados contra cualquier defecto de materia o fabricación, durante un periodo de 10 años y esto, a partir de la fecha de compra inscrita en la factura o recibo de caja. En caso de reclamación, deberá

comunicarnos el número de serie del cobertizo "Garden Home", así como la referencia de la pieza defectuosa y presentar imperativamente el justificante de compra (factura, recibo de caja). Estas informaciones están indicadas en el manual de montaje, así como en nuestra página web www.grosfillex-gardenhome.com. Por tanto, piense en conservar bien su justificante de compra y su manual de montaje. En el caso de que se le cambie una pieza que falle o que esté defectuosa, cubierta por la garantía, Grosfillex se compromete a entregarle, sin gastos, dicha pieza en el más breve plazo. En caso de que una pieza cubierta por la garantía no estuviese disponible, Grosfillex la reemplazará por otra pieza que se adapte perfectamente y de calidad idéntica. Si tuviera cualquier tipo de problema con el cobertizo "Garden Home", le rogamos contacte con nuestro servicio al consumidor vía nuestra página Web (www.grosfillex-gardenhome.com) o por correo, a la siguiente dirección:

GROSFILLEX ESPANOLA SA
Garden Home
Cityparc
CTRA. De Hospitalet, 147-149
Edificio Berlin
08940 Cornellà de Llobregat

Risponderemos cuanto antes a su reclamación.

EXCLUSIONES DE GARANTÍA

Le informamos que nuestra garantía queda excluida en los siguientes casos:

- modificación o alteración del producto por el cliente,
- incumplimiento de las recomendaciones de montaje, utilización o mantenimiento,
- utilización de piezas o componentes no suministrados por Grosfillex,
- uso excesivo de la fuerza durante el ensamblaje de los componentes,
- alteración del PVC debido a la emanación de productos químicos almacenados en el cobertizo,
- deformación del cobertizo debido al almacenamiento de objetos pesados contra las paredes,
- fijación de ganchos, tornillos, soportes o sistemas de suspensión, diferentes de aquellos suministrados o recomendados por Grosfillex,
- decoloración progresiva del PVC debida a la exposición a los rayos solares,
- desgaste vinculado a la utilización y/o al envejecimiento normal del producto,
- uso de productos abrasivos o detergentes para limpiar el cobertizo "Garden Home",
- Deformación debida a la ausencia de cimientos o a cimientos defectuosos
- daños causados por riesgos climáticos excepcionales (tormentas, huracanes, rayos, inundaciones),
- choques causados por proyectiles.



INFORMATIE EN WAARBORG

Geachte klant,

U heeft zojuist een Grosfillex Garden Home tuinhuis aangekocht. Wij feliciteren u met uw keuze en danken u voor het vertrouwen dat u in ons stelt.

Reeds meer dan 50 jaar besteden wij bijzondere aandacht aan de kwaliteit van onze producten. De kwaliteit van de gebruikte materialen wordt voortdurend streng gecontroleerd om u producten te kunnen leveren die aan uw verwachtingen voldoen.

NUTTIGE INFORMATIE

Het tuinhuis dat u zojuist heeft aangekocht werd ontworpen voor eigen gebruik. Het dient dus in geen geval om mensen te ontvangen of een handelsactiviteit in uit te oefenen. Afhankelijk van de plaats en de ingenomen oppervlakte ervan, is het mogelijk dat voor de opbouw van dit tuinhuis een kleine bouwvergunning of voorafgaande aanvraag tot bouwvergunning is vereist. Wij raden u dan ook aan om, alvorens met de werken te starten, bij de bevoegde gemeentedienst hierover de nodige informatie in te winnen.

Wij dringen er bovendien op aan u op een aantal gevaren te wijzen:

- werk vooral niet met vuur in de buurt van of in het tuinhuis,
- zet het tuinhuis niet op een plaats waar het hevig waait,
- maak het vooral goed vast aan de ondergrond,
- zorg voor een goede fundering om het tuinhuis stevig aan de ondergrond vast te maken,
- blijf bij extreme hitte niet te lang in het tuinhuis en vermijd in deze omstandigheden vooral de aanwezigheid van voedsel, jonge kinderen en oudere mensen.

GARANTIEBEPALINGEN

Zoals op alle producten uit ons gamma is ook op dit tuinhuis een Grosfillex garantie van toepassing, onder de volgende voorwaarden: op dit tuinhuis wordt samen met alle onderdelen een garantie van 10 jaar verleend voor materiaal- of fabricagefouten, te rekenen vanaf de aankoopdatum die zich bovenaan de factuur of op het betalingsbewijs bevindt. In geval van klachten is, zonder uitzondering, de vermelding van het serienummer van het Garden Home tuinhuis én de referentie van het defecte onderdeel vereist. Bovendien moet uw aankoopbewijs kunnen worden voorgelegd (factuur of kassabon). Deze informatie www.grosfillexgardenhome.com. Bewaar dus zorgvuldig uw aankoopbewijs en de montage instructies. Wanneer een ontbrekend of defect onderdeel moet worden vervangen dat gedekt is door de garantie, verbindt Grosfillex zich ertoe om u dit onderdeel kosteloos en binnen de kortste termijnen te bezorgen. Is een door de garantie gedekt onderdeel niet langer beschikbaar, dan zal Grosfillex het vervangen door een gelijkwaardig onderdeel van dezelfde kwaliteit. Ondervindt u problemen met het Garden Home tuinhuis, gelieve dan contact op te nemen met onze consumentendienst via onze website

GROSFILLEX S.A.S.
S.A.V. Garden Home
Arbent 01100 OYONNAX FRANCE

Wij behandelen uw klacht binnen de kortste termijnen.

UITSLUITING VAN WAARBORG

Volgende gevallen zijn in geen geval door de garantie gedekt:

- wijziging of beschadiging van het product door de klant zelf,
- niet-naleving van de montage-, gebruik- of onderhoudsvoorschriften
- gebruik van stukken of onderdelen die niet door Grosfillex werden aangeleverd,
- overmatige krachtzetting bij het monteren van de onderdelen,
- beschadiging van het PVC door de uitwaseming van chemische producten bewaard in het tuinhuis,
- vervorming van het tuinhuis door de opstapeling van zware voorwerpen tegen de wanden,
- het vastmaken van andere haken, vijzen, steunen of ophangsystemen dan die voorgeschreven door Grosfillex,
- geleidelijke ontkleuring van het PVC door blootstelling aan zonnestralen,
- slijtage door gebruik en/of normale veroudering van het product,
- gebruik van bijtende middelen of zepen bij het onderhoud van het Garden Home tuinhuis,
- vervorming te wijten aan de afwezigheid of beschadiging van de funderingen,
- schade veroorzaakt door uitzonderlijke weersomstandigheden (storm, orkaan, bliksem, overstroming),
- schokken veroorzaakt door projectielen.



INFORMAÇÕES E GARANTIA

Caro Cliente,

Parabéns, acaba de adquirir um abrigo de jardim Grosfillex Garden Home. Agradecemos a sua preferência e a sua confiança.

Há mais de 50 anos que damos uma atenção particular à qualidade dos nossos produtos. A qualidade dos materiais utilizados é rigorosamente e repetidamente controlada para lhe fornecer um produto que corresponda às suas expectativas.

INFORMAÇÕES

O abrigo de jardim que acaba de adquirir foi concebido para uma utilização privada. Por conseguinte, não foi concebido para acolher público nem para exercer qualquer tipo de actividade comercial. Consoante o lugar onde se constrói e a superfície em questão, a construção do seu abrigo de jardim pode estar condicionada a um pedido prévio de licença de obra. Aconselhamos que se informe na junta de freguesia competente para obter todas as informações úteis antes de começar as obras. Finalmente, chamamos a atenção para algumas práticas fortemente desaconselhadas:

- trabalhos com chama nua a proximidade ou no interior do abrigo,
- Edificação do abrigo num lugar fortemente exposto ao vento,
- Defeito de fixação do abrigo ao chão,
- Fixação do abrigo directamente no chão, sem alicerces,
- Presença prolongada no abrigo em caso de exposição a um forte calor, em particular para os bebés, as crianças e os idosos.

GARANTIA - MODALIDADES

O seu abrigo de jardim beneficia, tal como todos os produtos da nossa gama, da garantia Grosfillex segundo as modalidades seguintes: Grosfillex garante que o seu abrigo de jardim e as suas componentes estão livres de defeitos de fabrico pelo período de 10 (dez) anos contados a partir da data de compra indicada na sua factura ou no talão da caixa. Em caso de reclamação, é imperativo indicar o número de série do seu abrigo Garden Home, assim como a referência da peça defeituosa e apresentar o seu justificativo de compra (factura, talão da caixa). Estas informações figuram no seu folheto de montagem, assim como no nosso site www.grosfillex-gardenhome.com. Não se esqueça de conservar o seu documento justificativo da compra e o seu folheto de montagem. Em caso de substituição de uma peça em falta ou defeituosa durante o período de garantia do produto, Grosfillex compromete-se a fornecer-lhe, sem custos, essa peça o mais brevemente possível. Se a peça com garantia já não estiver disponível, a substituição do produto defeituoso pode ser feita por um produto adaptável e de qualidade idêntica. Caso tenha um problema com o seu abrigo Garden Home, faça favor de entrar em contacto com o nosso serviço de apoio aos consumidores através do nosso site Internet (www.grosfillex-gardenhome.com) ou por correio endereçado a:

GROSFILLEX S.A.S.
S.A.V. Garden Home
Arbent 01100 OYONNAX FRANCE

Daremos uma resposta à sua reclamação o mais depressa possível.

EXCLUSÕES DE GARANTIA

Estão excluídos da garantia os defeitos provenientes:

- da modificação ou alteração do produto pelo cliente,
- do não respeito dos conselhos de montagem, de uso ou de manutenção,
- da utilização de peças ou componentes não fornecidos pela Grosfillex,
- do uso excessivo da força durante a montagem das componentes,
- da alteração do PVC devida às emanações de produtos químicos armazenados no abrigo,
- da deformação do abrigo devida ao armazenamento de objectos pesados contra as paredes,
- da fixação de ganchos, de parafusos, de suportes ou de sistemas de suspensão que não sejam fornecidos ou aconselhados pela Grosfillex,
- da decoloração progressiva do PVC devida à exposição aos raios solares,
- do desgaste devido à utilização e/ou ao envelhecimento normal do produto,
- do uso de produtos abrasivos ou de detergentes para limpar o seu abrigo Garden Home,
- da deformação devida à ausência de alicerces ou a alicerces defeituosos,
- de estragos provocados por condições climáticas excepcionais (tempestade, furacão, raio, inundações),
- de choques provocados por projecteis.

Grosfillex - Arbent
F-01107 Oyonnax

Tél. 00 33 (0)4 74 73 30 30
Fax 00 33 (0)4 74 73 32 30
www.grosfillex-gardenhome.com