

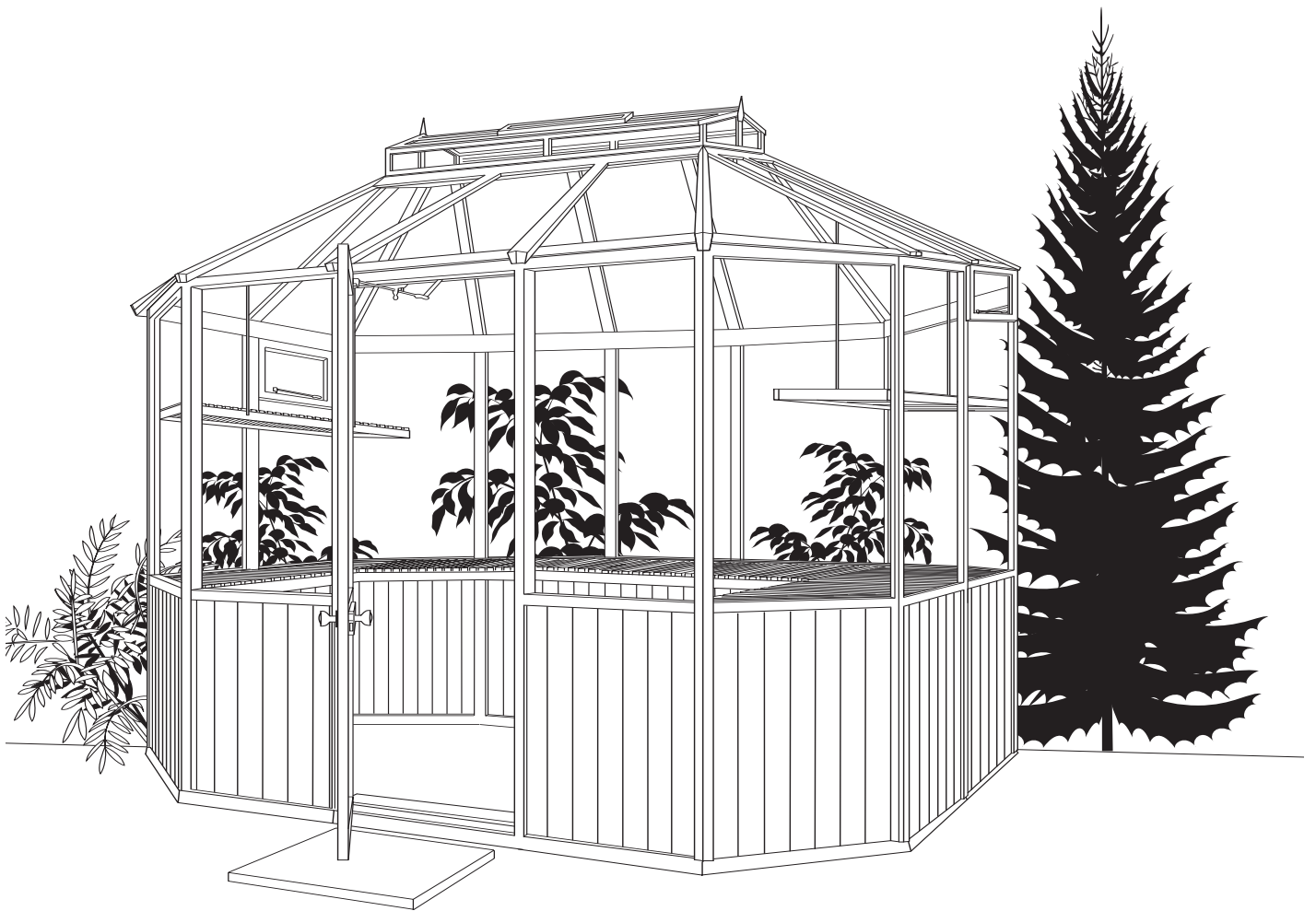

8'x 11' OCTAGONAL CEDAR GREENHOUSE



ASSEMBLY INSTRUCTIONS

PLEASE READ ALL INSTRUCTIONS BEFORE PROCEEDING



8'x 11' OCTAGONAL CEDAR GREENHOUSE

Assembly Instructions

Contents Page

Introduction	3
Safety Advice	3
Fitting Service	3
Siting your Greenhouse	3
Unpacking the Greenhouse	3
8x11 Octagonal Concrete Base	4
Kerb Laying Instructions	5
Tools required to erect the Greenhouse	5
Side Assembly	6-8
Door Fitting	9
Roof Assembly	10-11
Fixing Eave Braces	11
Fixing Lantern to Roof	12-14
Automatic Vent Openers	14
Fixing Finial to Roof	15
Fixing Glass to Roof	15
Fitting of Door Stop	16
Fitting Window Casement	16
Staging	17-18
High Level Shelving	19
Glass Details	Back Cover



8'x 11' OCTAGONAL GREENHOUSE

Introduction

Thank you for buying an Alton Cedar Greenhouse. Please read carefully through these instructions before beginning to put your greenhouse up.

Safety advice

It is advisable that the greenhouse should be assembled by two people and extra help will be required, maybe 4 people, to lift the roof into place. Particular care should be taken when handling glass and the wearing of gloves is strongly recommended. Favourable weather conditions should be chosen. Do not try and erect the building in windy conditions - the panels can be difficult to handle in high winds.

All side frames should be suitably propped until the roof frames are secured.

Keep children and pets away until the work is finished.

Take your time - rushing causes accidents.

Fitting service

Please call your local dealer if you would like to have a quote for the erection of your greenhouse by an installer.

Siting your greenhouse

The choice of position may be limited but it is advisable to consider the following advice. A flat level site is essential and further information on the preparation of the ground is given below.

It is necessary to leave sufficient working room around your greenhouse when you're putting it up and also to allow for the possible need to replace a piece of glass in the future.

If possible try and leave a space of 2ft (610mm) around the greenhouse.

Locate the greenhouse where there is maximum amount of sunlight and avoid if possible any shade from trees, fences or other buildings.

Over hanging branches can be a particular nuisance and should be avoided.

Choose a site where the greenhouse is relatively easy to get to and convenient to bring water to and possibly a supply of electricity.

Finally, and most importantly choose a site where your Alton Greenhouse will look right as it will be a complement to your garden.

Unpacking the greenhouse

Carefully remove all the packaging. If using a knife be careful not to cut into the Cedar wood.



8x11 OCTAGONAL CONCRETE BASE

THESE DIMENSIONS ARE APPROXIMATE ONLY

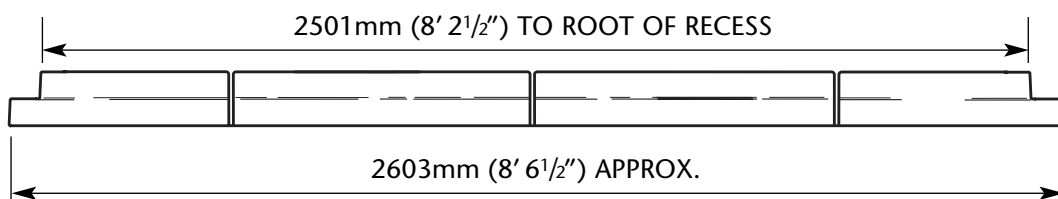
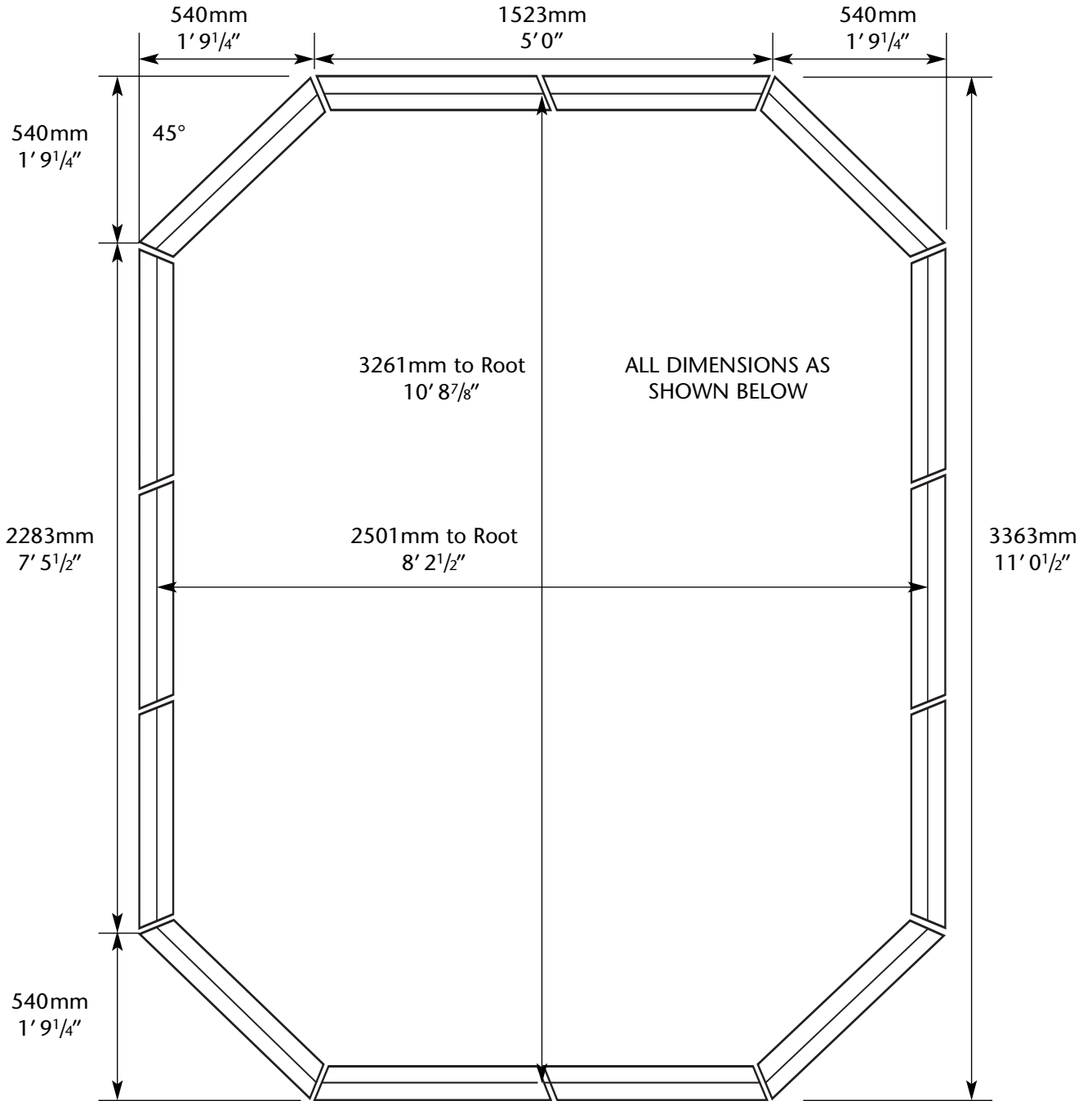

1. Site preparation

It is essential that the concrete base kerbs are laid on firm level ground that is unlikely to let the greenhouse sink into it after a number of years. If the site for the greenhouse is not firm, level or well drained it is advisable to lay concrete footings as illustrated, or lay paving slabs. The depth of footings will depend on the nature of the ground on your site. For practical purposes a spade's width and depth may be preferred.

3. Grouting

Grout joints between the kerbs after assembly with sand/cement mortar mix.

4. Important note

It is vital that the footings are level and sited on firm ground. If not, this will undoubtedly affect the construction of the greenhouse.

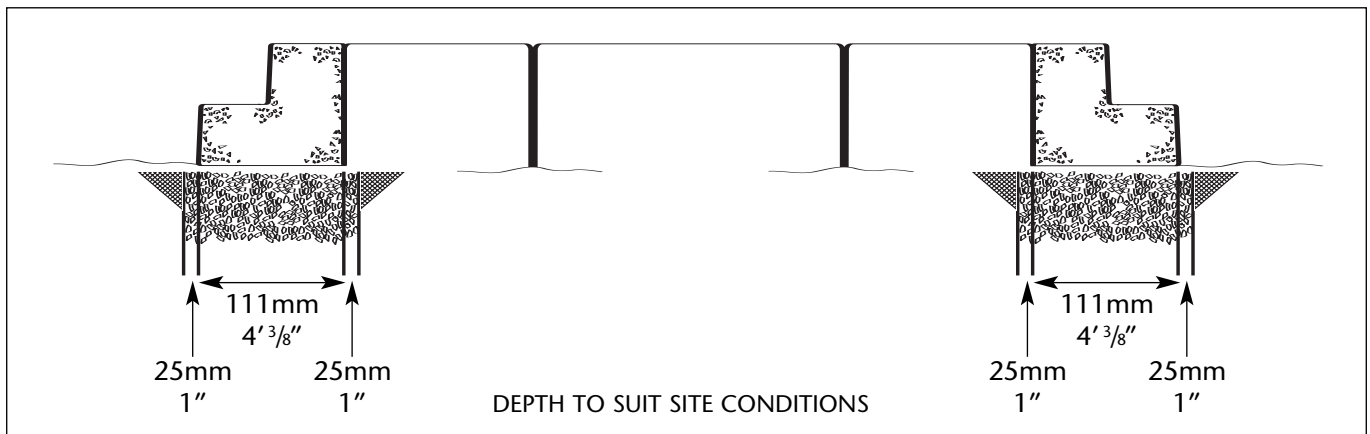

2. Setting out the concrete kerbs

The kerbs should be laid out according to the dimensions given opposite.

Check the diagonal measurements both ways to ensure squareness.

As a result of the manufacturing process the kerbs can in some cases be uneven on the underside and may need to be bedded on a dry sand/cement mix to correct any inaccuracy.

NOTE: It is advisable to choose a calm day before proceeding with assembly, and to have extra help to hand when erecting the side and roof frames.

The following tools will be required:-

- Small hammer
- Screwdrivers - slot and posi-drive
- Drill
- Drill bits 8mm and 4mm
- Stepladder (reasonably tall)
- Bradawl
- Spirit Level
- Spanner (17mm)
- Tape Measure
- Mastic Gun



SIDE ASSEMBLY

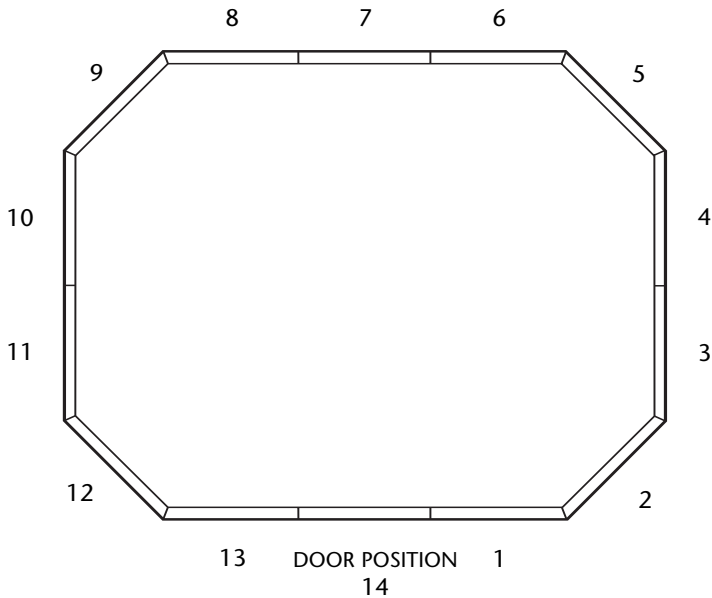

EXAMPLE LAYOUT

Safety Note

It cannot be emphasised enough at this stage how important it is to hold the sections steady. As the number of frames increase, so the area for the wind to blow against it increases, additional help is essential.

Ideally 3 or 4 persons should be used to hold the frames whilst they are fixed in position. Alternatively use props to support the frames, positioning and securing these in such a way so as not to break any glass.

Start by deciding the required position for the opening windows.

Proceed with assembly of frames.

Starting with frame 1 placing it in the rebate of the base plinth, securing it in position with a base plinth fixing bracket 16-1306 and M10 x 16mm bolt 02-1562.

Screw bracket to frame using 1" No. 8 round head screws 02-1852.

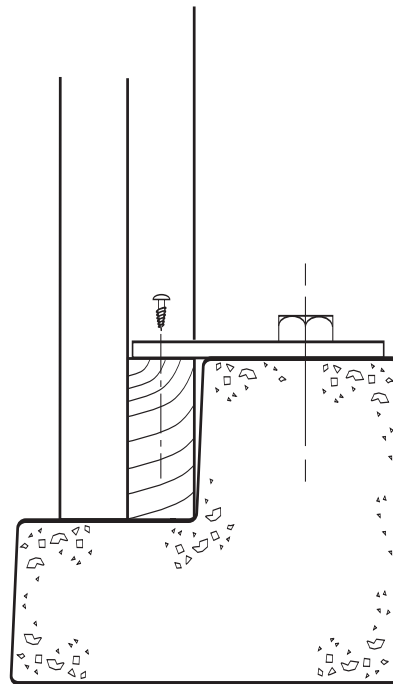

It will be necessary for the first frame to be held upright at this stage whilst a 6mm bead of mastic is applied to the left hand edge of the frame.

(That is looking at it from inside the building)

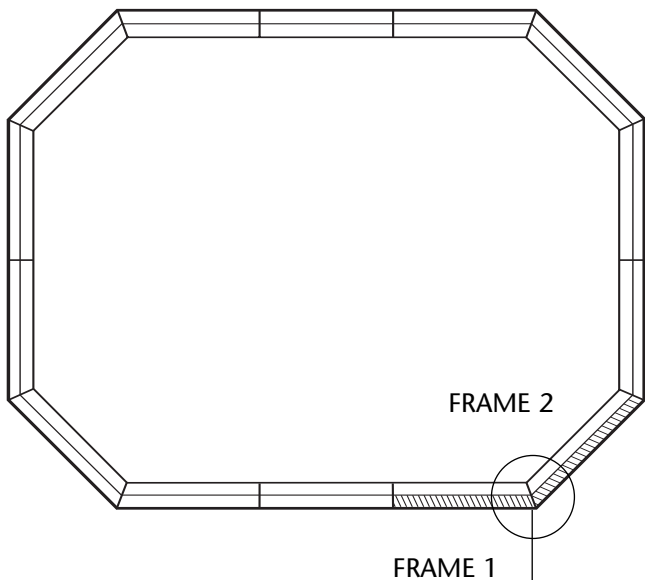

Continue to hold frame 1 steady, whilst frame 2 is offered into position and secured using 2" x No.10 countersunk head screws 02-1826

Continue to mastic each panel edge and offer frame 3 into position securing as before.

The connecting post for joining two frames on the long side should first be connected to the side of the frame which does not have pre-drilled holes. Use 1 1/2" No. 10 CSK head screws.

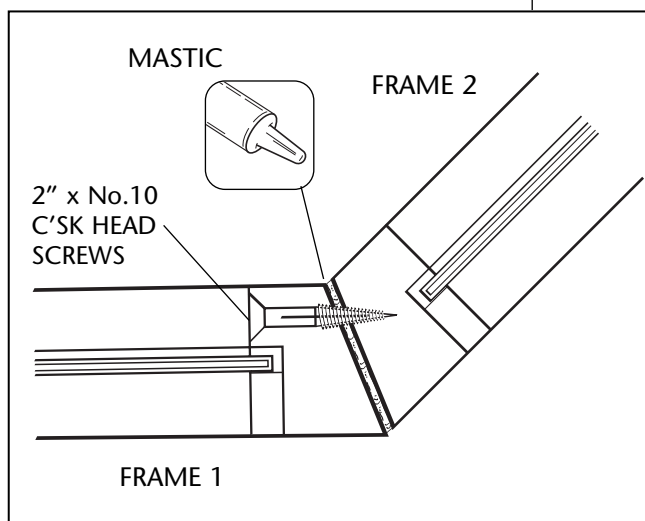

The next frame is simply joined in the usual manner through the pre-drilled holes.

Ensure that the angle on the top of the post is flush with the angle on top of the side frames.

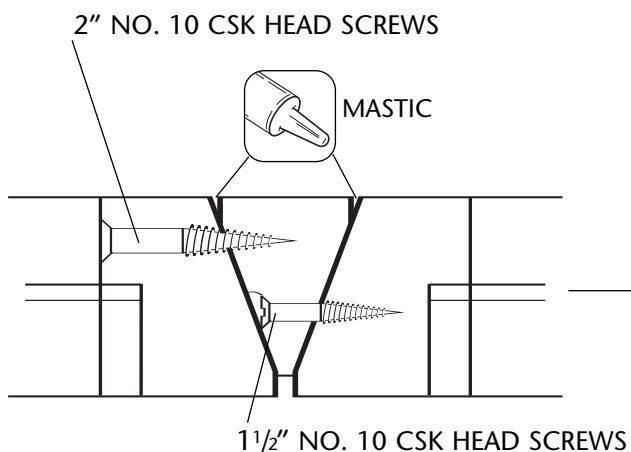

Continue to fix the remaining frames, until you get to the doorway.

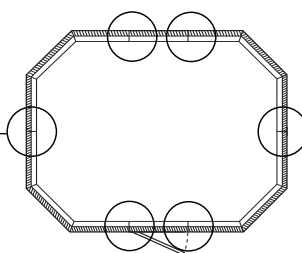



SIDE ASSEMBLY *continued*

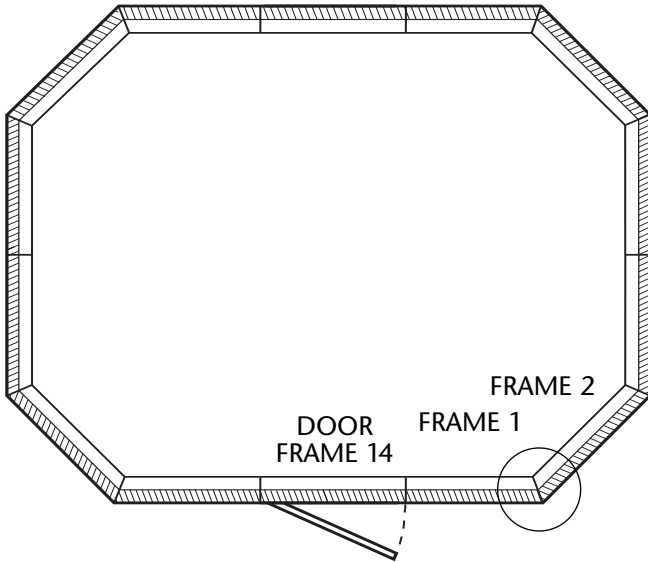

Still holding the frames secure, the door frame may be placed in position now.

Remember to put a 6mm bead of mastic down both edges of frame.

NOTE: Note that base kerb fixing bracket (16-1306) is not used in the door position.
A countersunk bracket is supplied 16-1459. Secure with CSK. Bolt M10 x 16 02-1556 and 1/2" x No. 6 CSK. Screw 02-1804.

DOOR IN CENTRE (Frame 14)

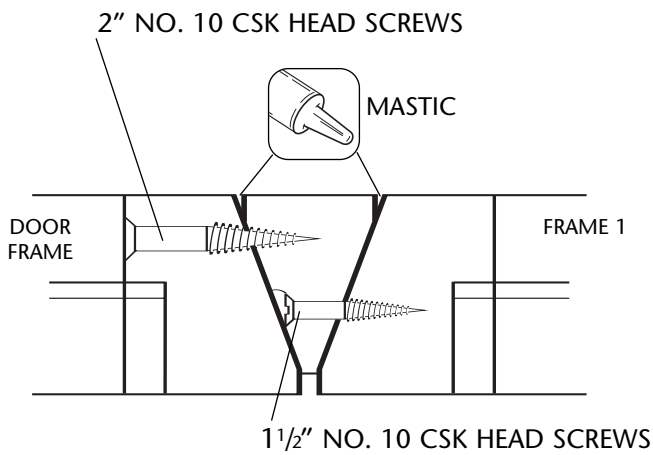



DOOR FITTING

Offer rimlock into position and with the door fully closed, position the striker plate as shown and secure with 1" X No. 8 screws (02-1810)

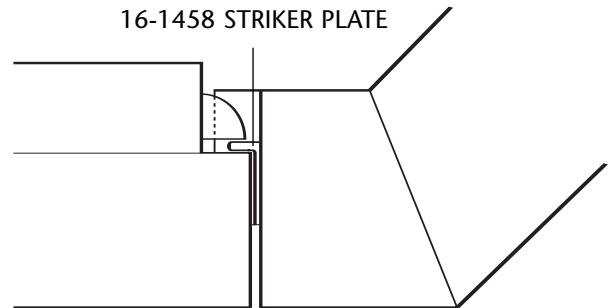

Position the rimlock in line with the striker plate so that the pawl will adequately project past the striker plate. Temporarily secure with 2 screws, No. 8 x 1 1/2" black jap round head and mark position for keyhole and spindle. Remove lock and drill 10mm hole for spindle and 8 x 22mm slot for the keyhole. Ensure the spindle turns freely, then secure the lock using 4 screws.

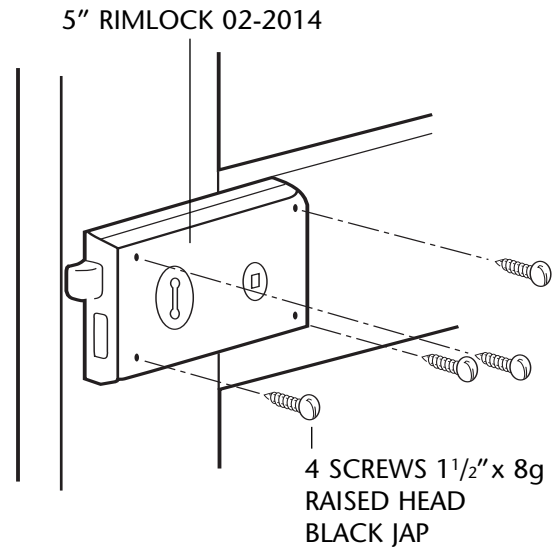

Fit the door knobs and keyhole escutcheon as shown. The door knobs are secured with 2 self-tapping screws.

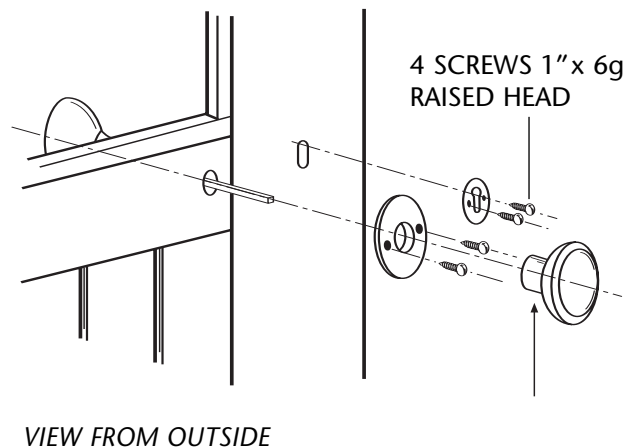

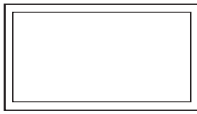

It is recommended that the assembly of the roof is completed at ground level and with assistance lifted into position, unglazed, when completed.

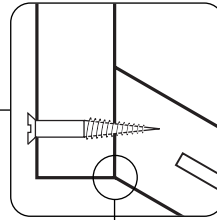
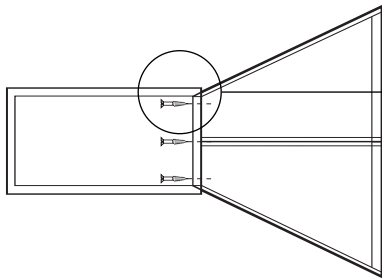

The square roof void frame, which is supplied ready assembled with angle brackets, must be connected to the top of a large roof frame with three 2" countersunk x No.10 screws.

ENSURE BOTTOM OF 'THE SQUARE' IS FLUSH

Fit opposite large roof frame in the same manner. The assembly will then be supported off the floor.

Fit the remaining two large frames.

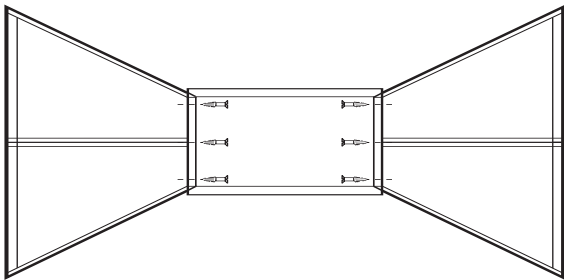

To fit the four triangle roof frames, first apply a bead of mastic. Then secure using 1 1/2" countersunk x No.10 screws.

Four per frame through the pre-drilled holes.

Clean off any surplus mastic that squeezes out of the joints, by carefully scraping it away using a thin piece of plastic or wood as a spatula.

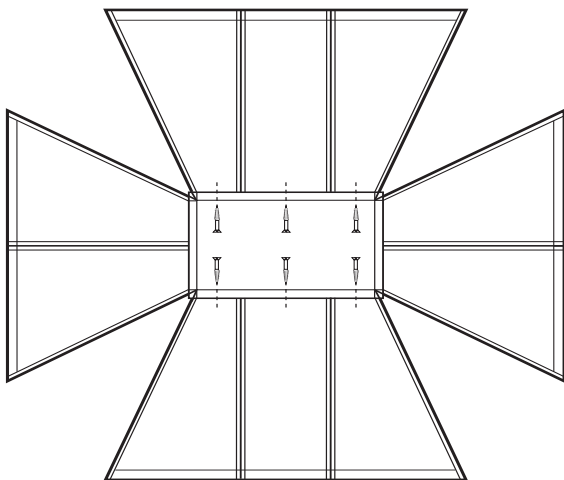

Safety Note

It cannot be emphasised enough at this stage how important it is to hold the sections steady. As the number of frames increase, so the area for the wind to blow against it increases, additional help is essential.

Ideally 3 or 4 persons should be used to hold the frames whilst they are fixed in position. Prior to lifting into position it is recommended that you tape the joining sections, using a strong but removable tape.

Remove tape before glazing but after securing the roof section to the sides.



ROOF ASSEMBLY *continued*

MASTIC

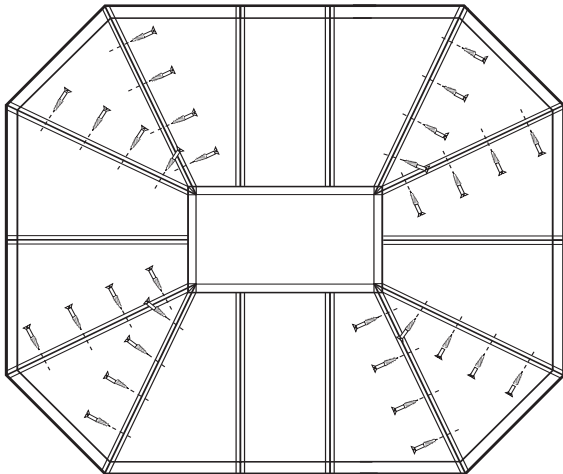

With assistance lift the completed roof into position, (tape joints) and by carefully moving the roof the correct position will be found, make sure that they have an even overlap all round before securing with 1³/₄" countersunk x No.10 screws

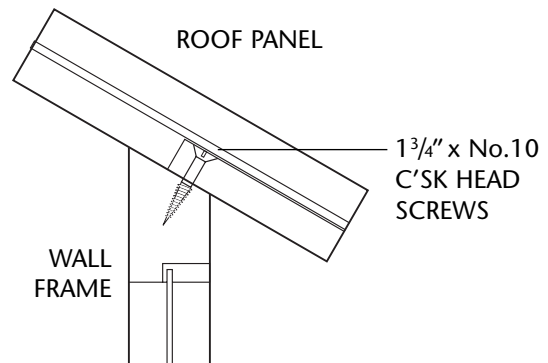

FIXING EAVE BRACES

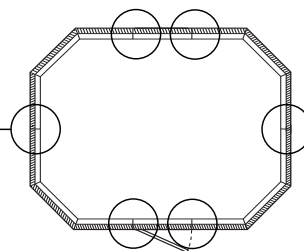
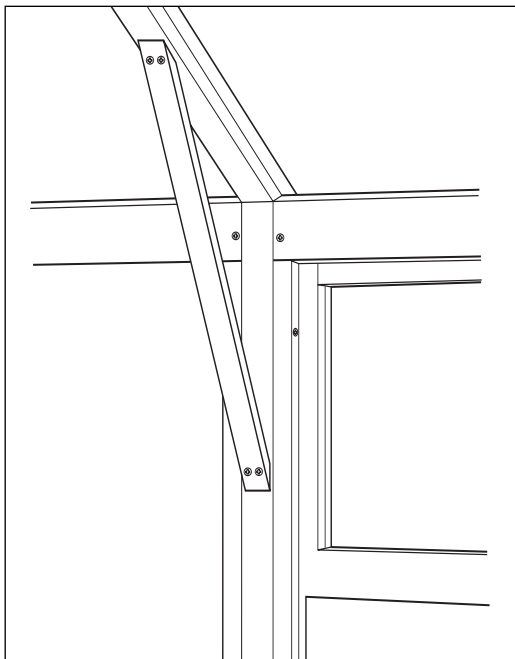

Fix the six eave braces as shown in the diagram. Position centrally and secure each brace with four 1¹/₄" countersunk screws through the pre-drilled holes.

FIXING LANTERN TO ROOF

The main roof frames are now in position but should not be glazed yet.

The pre-glazed lantern frames can now be installed.

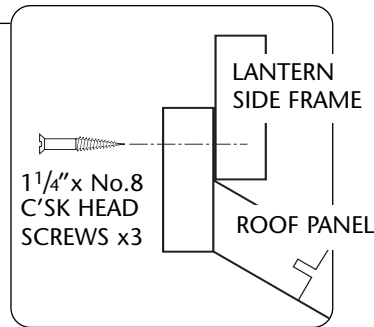
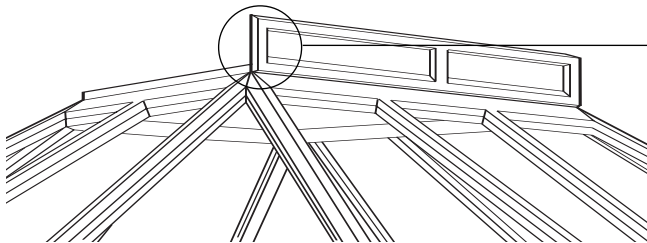

Fit the lantern side frames first. **KEEP FLUSH AT EACH END**

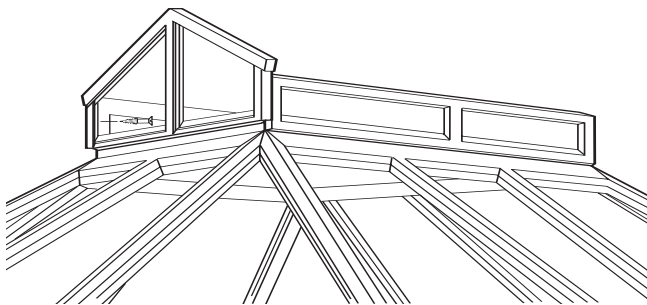

Fit second side frame opposite to first, then continue with a lantern gable frame ensuring it is positioned centrally and with the bevelled beading on the outside.

Secure with three screws into base rail as before, 1 1/4" countersunk x No.8 screws.

Then screw side frame to gable frame using 2" countersunk x No.10 screws, one per corner through the pre-drilled holes.

Repeat with other gable frames.

Centrally position ridge bar on top of gable frames and ensure it is flush at each end.

Fix down with 2" countersunk x No.10 screws.

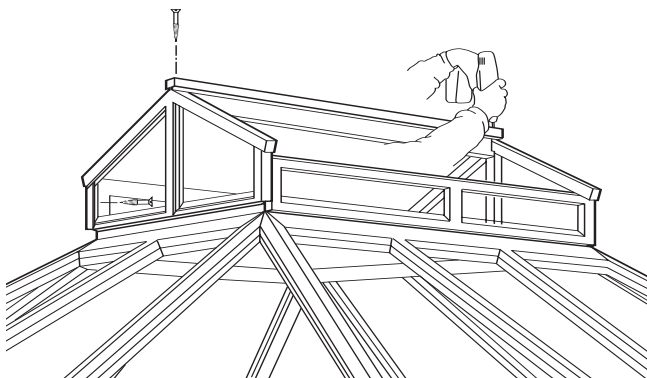

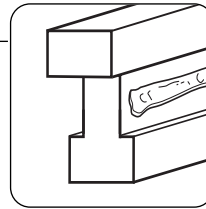
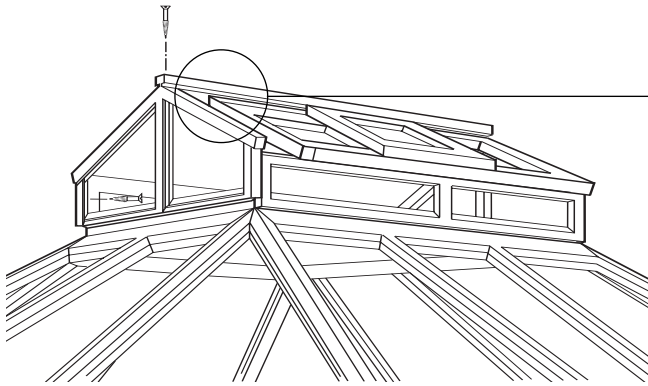

Apply 6mm mastic bead along rebate of ridge bar before sliding roof frames into position.

Screw side styles of roof frame into gable frames using 2" countersunk x No.10 screws.

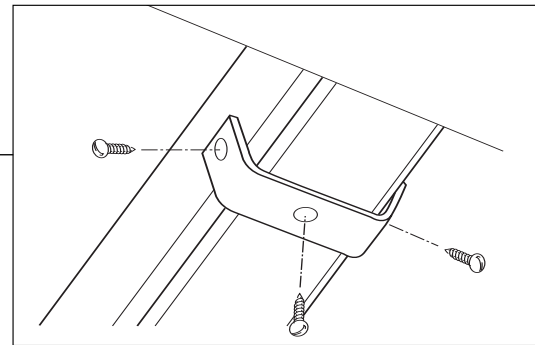
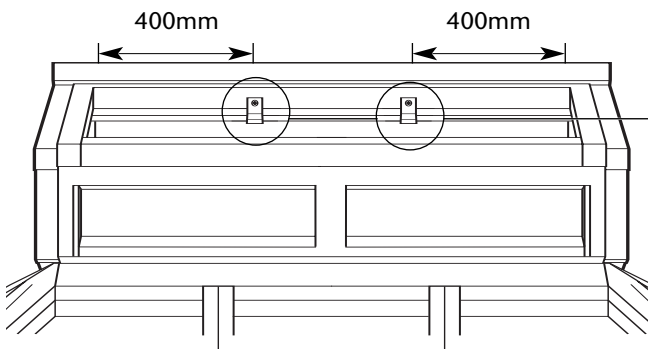

Fit ridge 'U' brackets 400mm from the ends of the ridge bar securing them to the ridge and top of roof frame using 3x1" No.10 round head screws.

Insert screws (2" x No.10 x1) through roof bottom rail to attach to top rail of side frame.

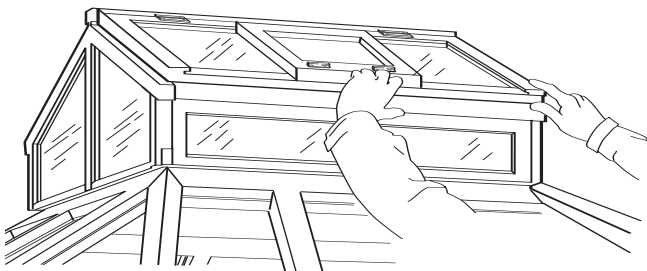

Position roof vent and pre-attached vent hanging rail tight up against ridge bar with an equal gap at each end.

Secure down through the pre-drilled holes using 2" countersunk x No.10 screws (x3).

Repeat operation for vent on the other side.



FIXING LANTERN TO ROOF *continued*

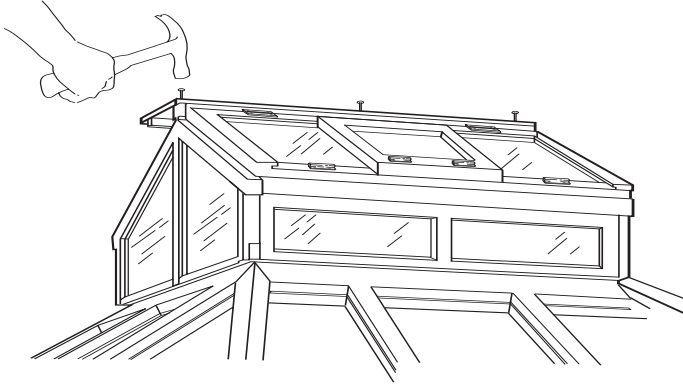

Nail down both vent caps to the top of ridge bar ensuring they are flush at each end.

Align with the centre of the ridge bar, so that the 'caps' overhang the hinges.

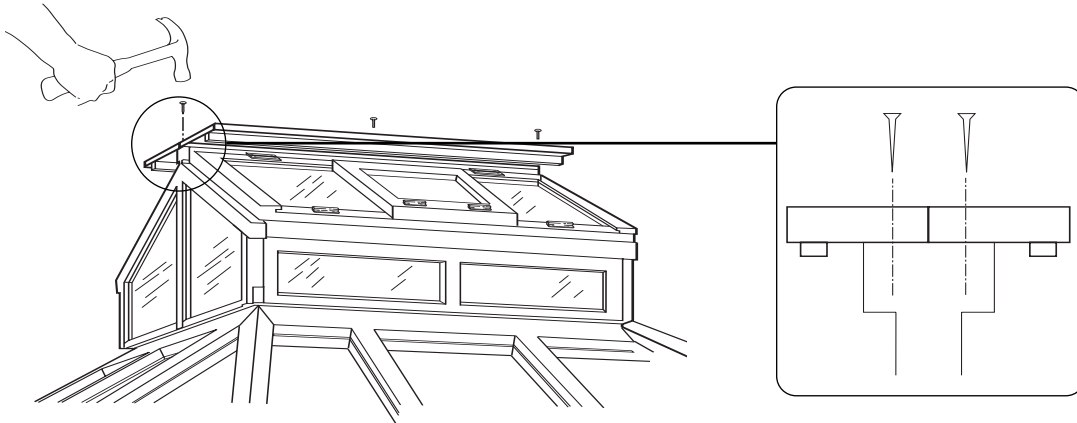

AUTOMATIC VENT OPENERS

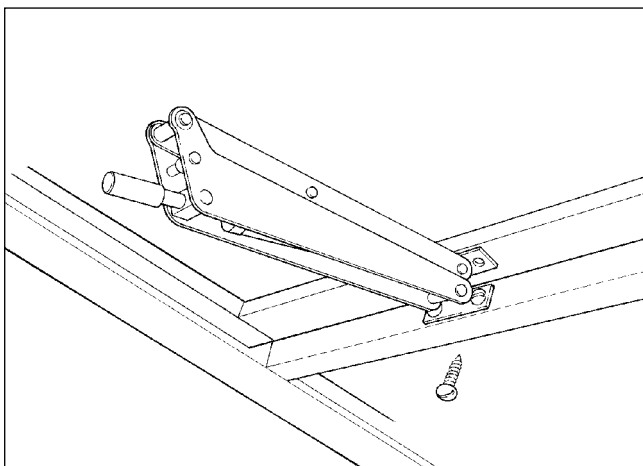

The automatic vent openers are supplied with separate fitting instructions.



FIXING FINIALS TO ROOF

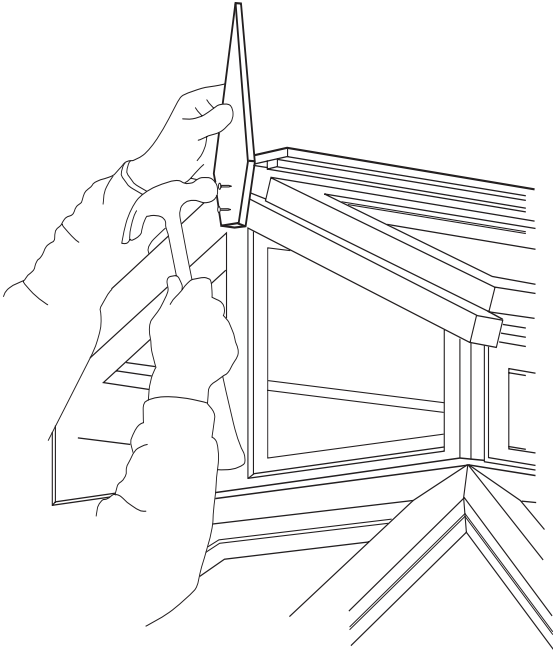

Centralise the finials and nail to both ends of ridge bar



FIXING GLASS TO ROOF

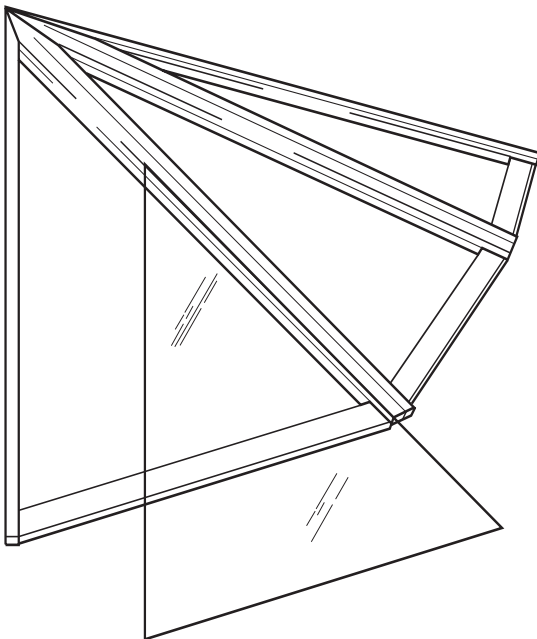

Offer a glass panel to a grooved member on one side of roof panel as shown, and slide up in direction of arrow. Extra help will be required at this stage inside the greenhouse to feed the other edge into the adjacent groove.

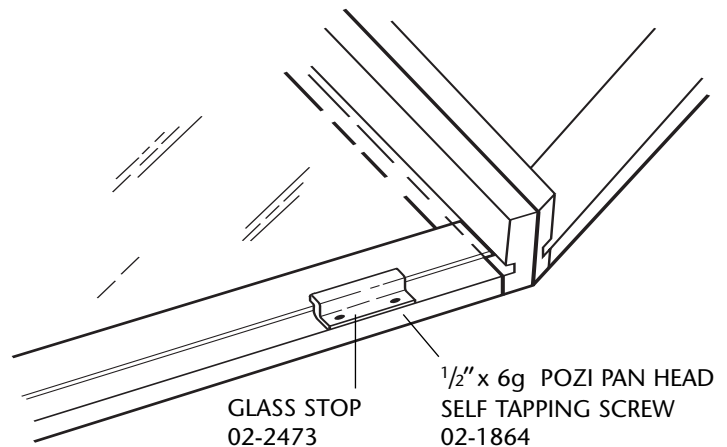

Safety Note

It is advisable to wear suitable gloves when handling glass.

Make sure that the glass grooves in roof panels are free of splinters etc.

When the glass is fully home, secure with two glass stops



FITTING DOOR STOP

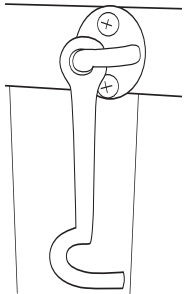

The plates to which the hook and staple are attached are about the same height as the mid rail and bead to which we have secured them. Therefore it is very important to provide a pilot hole (a bradle will do this easily enough) so that the screw does not split the timber when screwed into position. Screws are 02-1849 3/4 x 8 Pan Head Black

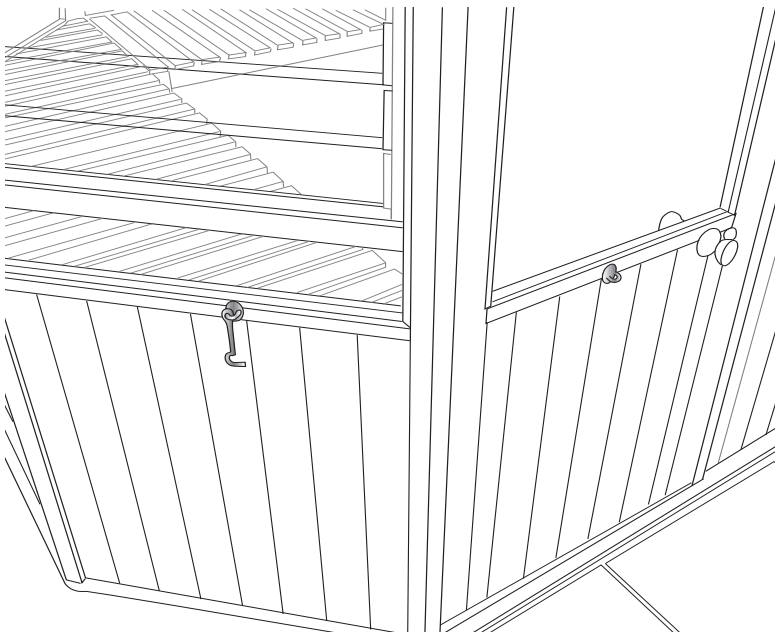
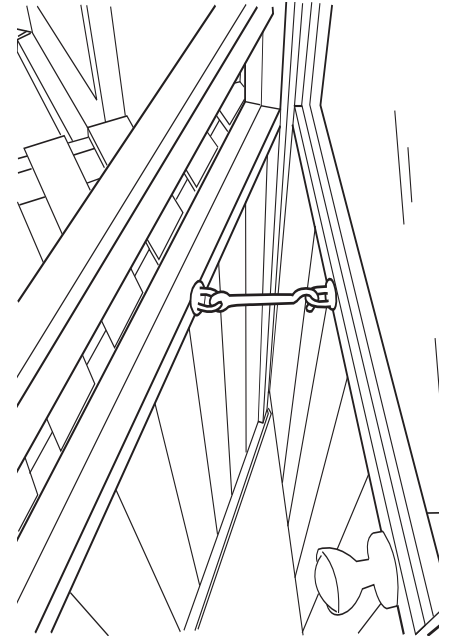

FITTING WINDOW CASEMENT

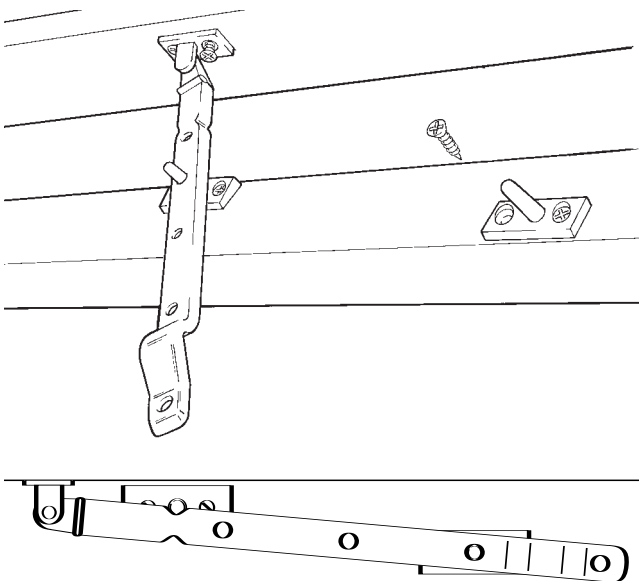

If you have not ordered an Automatic Opener as an optional extra we supply a casement stay for each side vent.

With the side vent closed fix the casement stay centrally to the side vent with 2 off 3/4" (19mm) countersunk screws as shown in fig 2.

Locate the positions of the two studs with reference to the casement stay. Note the position of the 'offset stud' and the 'central stud' from fig 3. When your happy they are in the correct position fix with 3/4" (19mm) countersunk screws.

To fix an Automatic Opener refer to the separate instructions supplied with the unit.

We do not supply a casement stay when an Automatic Opener is supplied.



SIDE & END STAGING

The plan below shows the layout of side and end staging, and the reference at A, B and C show the locations of the two types of bracket used.

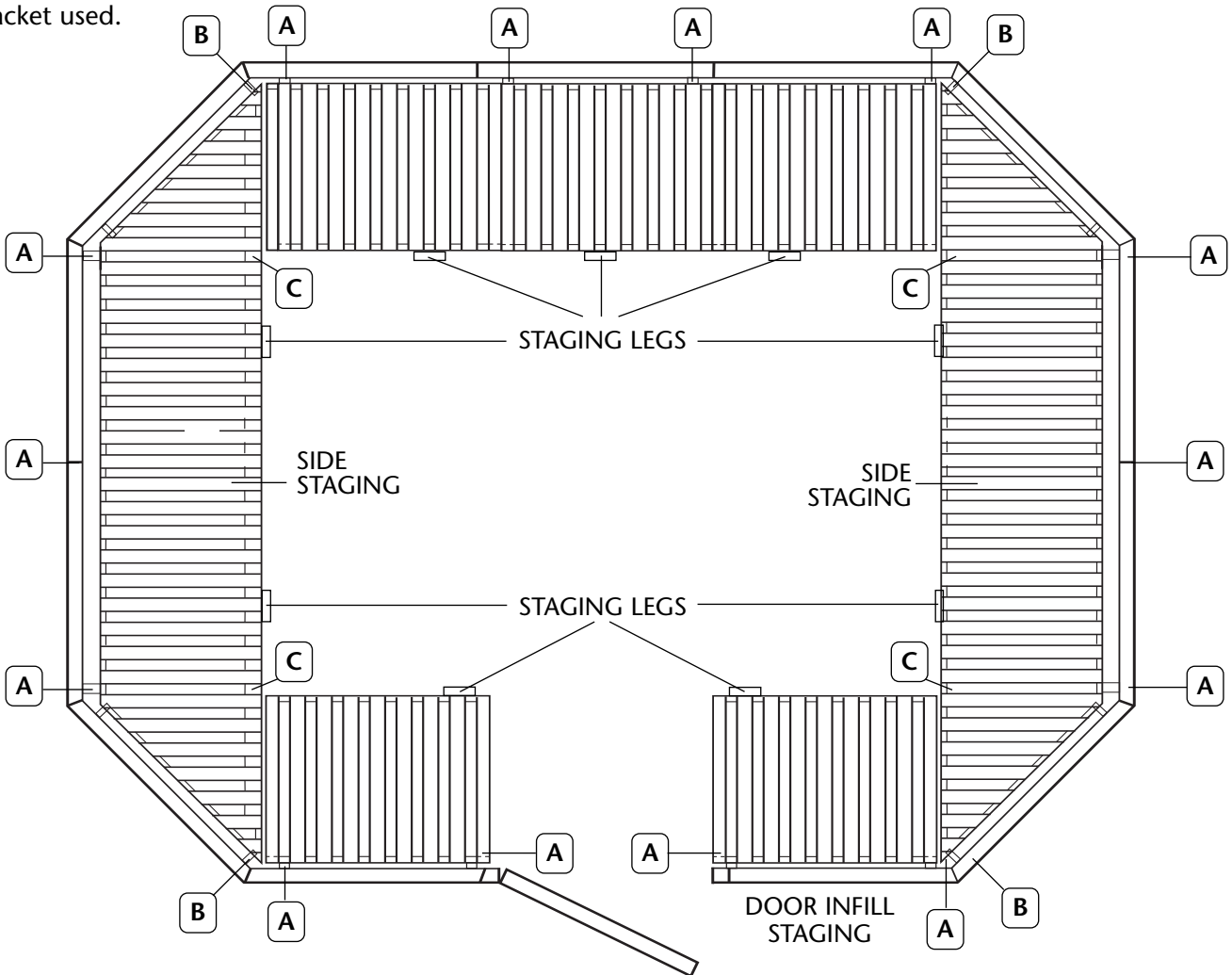

Offer the side staging into position and locate the 2 support legs as shown in lower drawing to determine height of staging.

Place a staging bracket 17-8005 under the back rail of staging, and after levelling mark the position of the bracket on the mid rail of the wall panel.

Repeat this operation at all points A for the side staging. Refer to points B, which show the positions of angle brackets 16-1303.

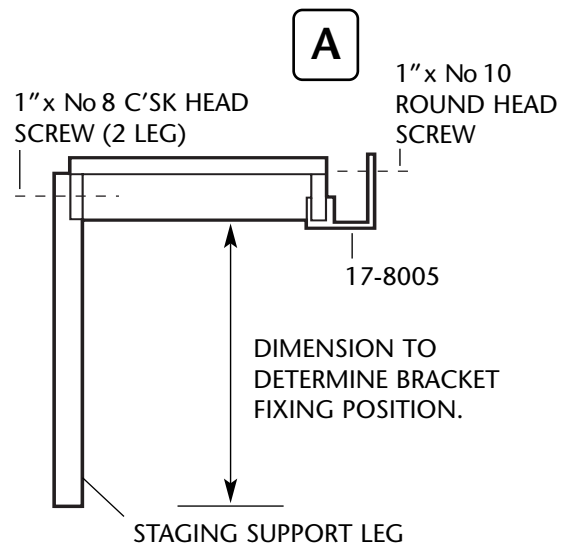

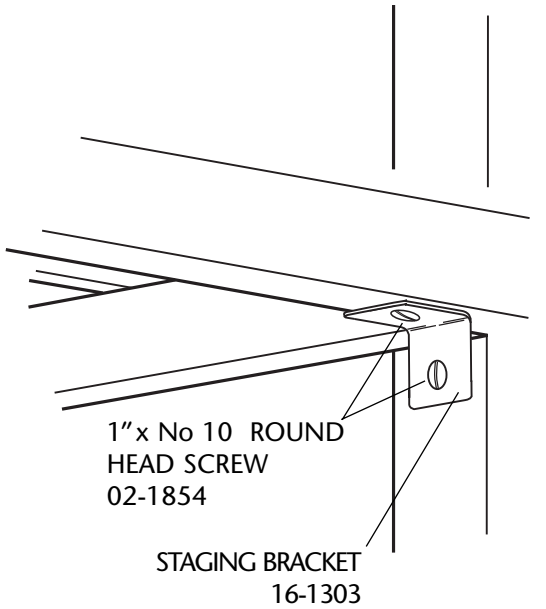

B

Refer to sketch on the left and to all points marked B on the previous page.

These show the positioning and fixing of the 90° staging bracket 16-1303 secured with 1" x No. 10 round head screws 02-1854.

The lower sketch refers to fitting the end staging.

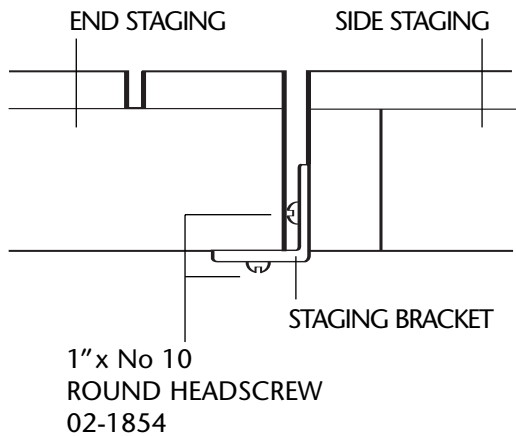

C

Fit 3 staging brackets 17-8005 as shown at point A on the previous page.

Now offer up the end staging to position the angle brackets 16-1303 at point C. These should be mounted flush with the end staging, and secured to the side staging as shown with 1" x No. 10 round head screws.

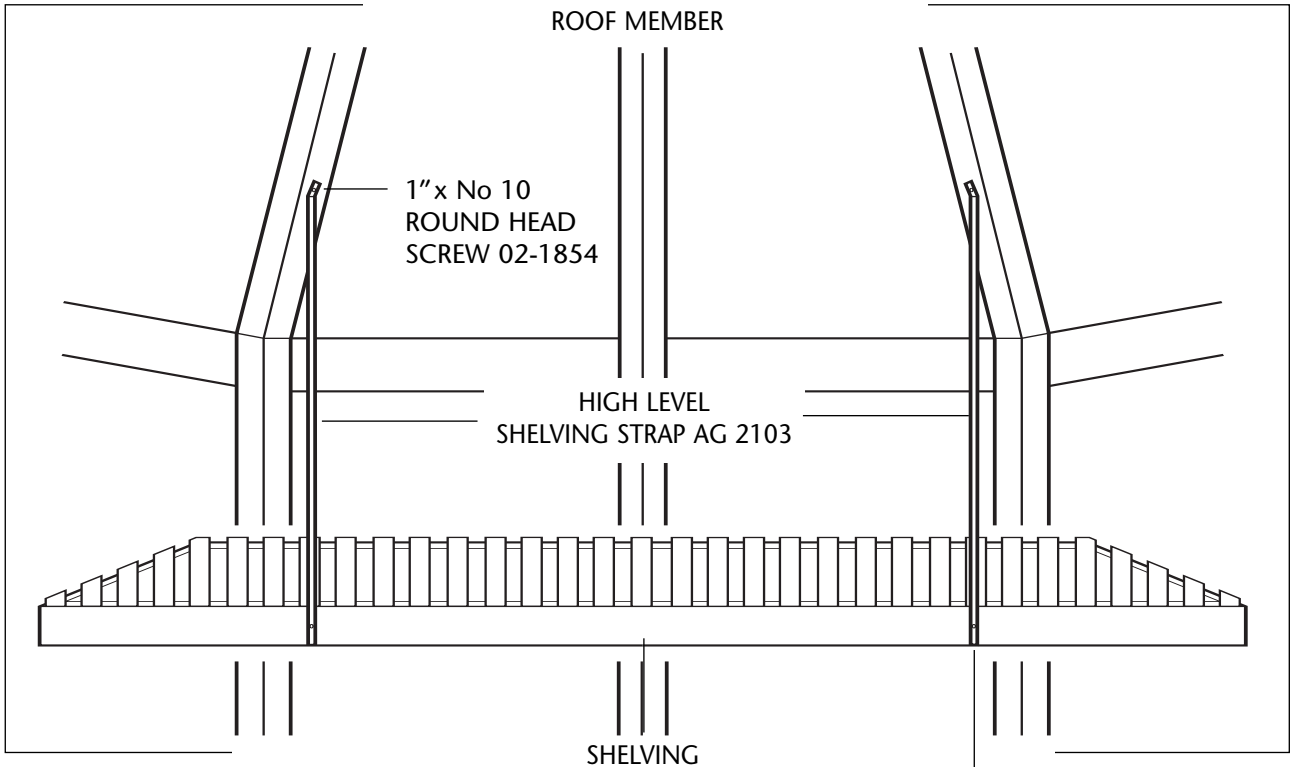

$\frac{3}{4}$ " x No 10 ROUND HEAD SCREW

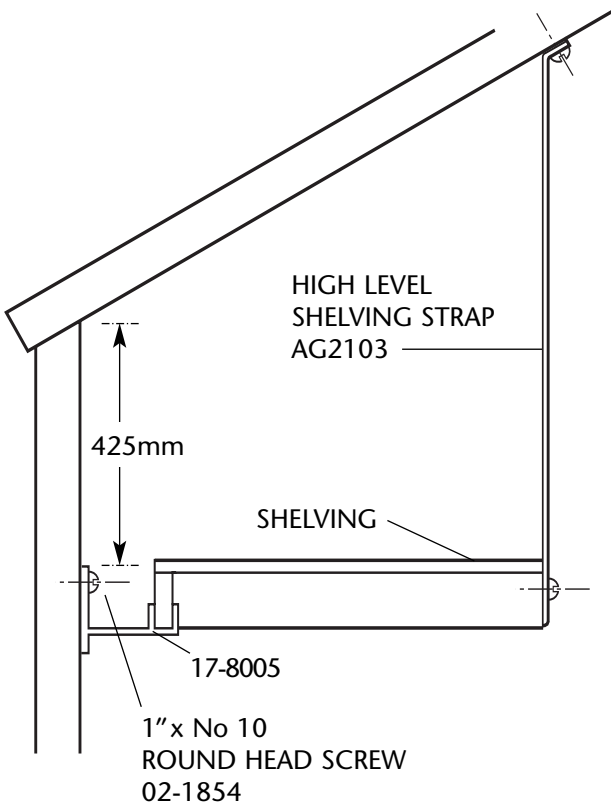

The high level shelving is mounted above the side staging. Mark the position of each staging bracket 425mm from the top of the side panel as shown, and secure the 2 brackets with 1" x No. 10 round head screws 02-1854. Now screw the shelving straps to the outside face of shelving rails and flush with the bottom face.

The assembly can now be placed in position with the rear rail located in the staging supports as shown, and the tops of the shelving straps secured to the roof members with 1" x No. 10 round head screws 02-1854.

The rear shelving is secured in the same way but is rectangular, ie: does not have angled ends.



8'x11' OCTAGONAL GREENHOUSE GLASS DETAILS

4mm TOUGHENED GLASS TO BS 6206 CLASS A

SIDE PANEL GLASS

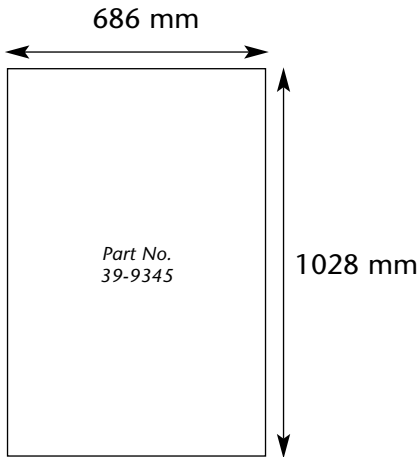

WINDOW GLASS

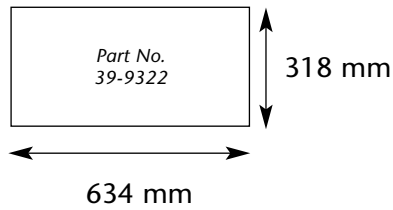

UNDER WINDOW GLASS

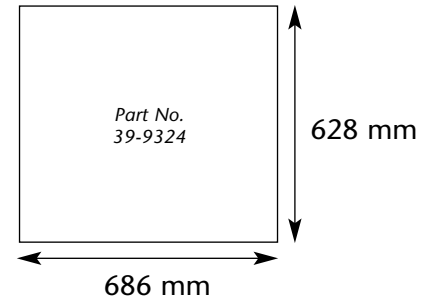

LANTERN GLASS

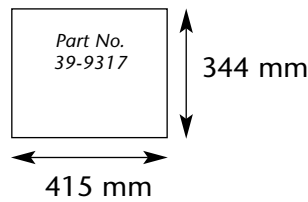

SIDE

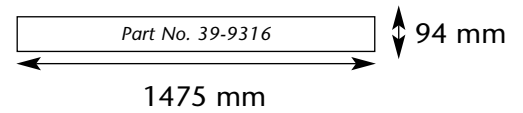

DOOR GLASS

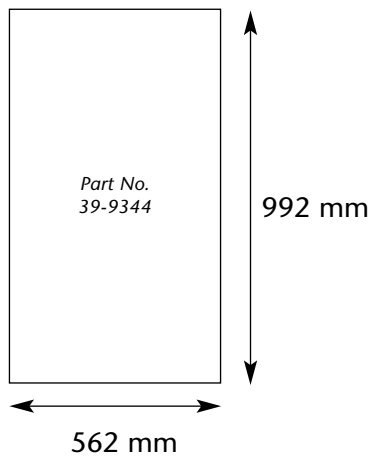

GABLES

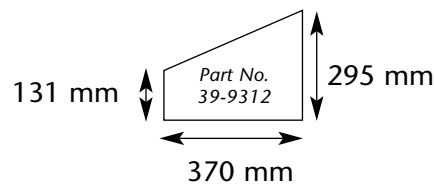

ROOF VENT

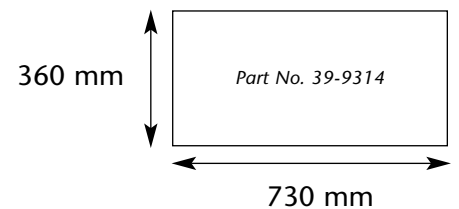

ROOF GLASS

