

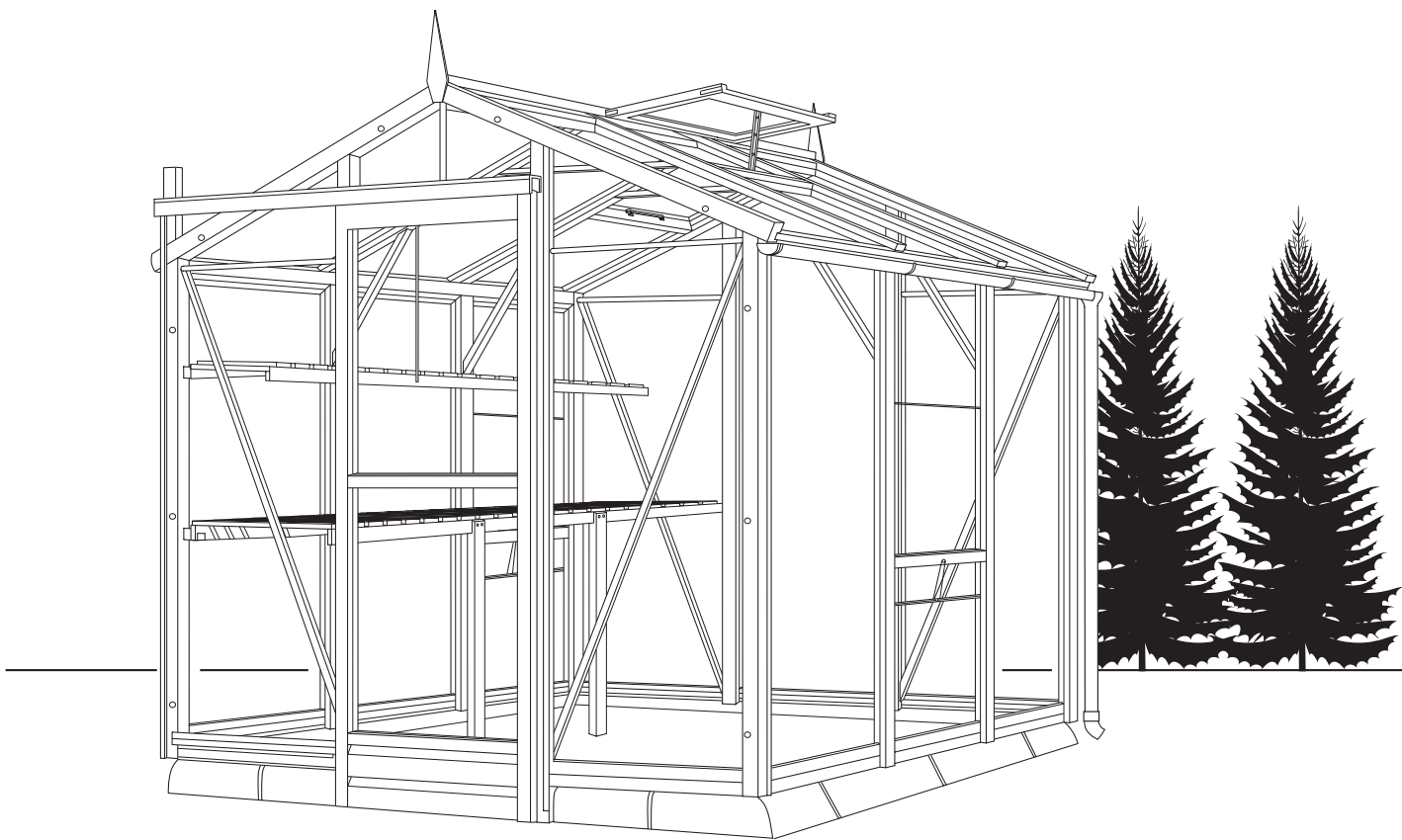

6'5" Wide TRADITIONAL CEDAR GREENHOUSE



ASSEMBLY INSTRUCTIONS

PLEASE READ ALL INSTRUCTIONS BEFORE PROCEEDING



6'5" WIDE TRADITIONAL CEDAR GREENHOUSE

Assembly Instructions

Contents Page

Introduction	3	Bracing & Supports	14
Safety Advice	3	Fixing Door	15-16
Fitting Service	3	Louvre Vents	OPTIONAL 17
Tools required to erect the Greenhouse	3	Ventilation	18
Planning and Preparation	3	Gutter Assembly and Fitting	19
Unpacking the Greenhouse	3	High Level Shelving	20
Optional Accessories	4	Staging Assembly	21
Siting your Greenhouse	5	Glass details	22
Site Preparation	5		
Concrete Base Kerb Dimensions	6		
Kerb Laying Instructions	6		
Fixing Cills to Concrete Kerb	7		
Fixing End Gable and Side Assembly	7-8		
Fixing the remaining Side Panels	8-9		
Fixing Door End Gable	9		
Preparation and Fixing of Ridge Bar	10		
Fixing of Roof Panels	11-12		
Fixing of Roof Fascias and Finials	13		



YOUR NEW CEDAR GREENHOUSE

Introduction

Thank you for buying an Alton Cedar Greenhouse. Please read carefully through these instructions before beginning to put your greenhouse up.

Optional Extras

It is extremely important that you assemble your optional extras in the correct position. Throughout these instruction references will be made to each optional extra. Please refer to the appropriate page or leaflet for full details.

Safety advice

It is advisable that the greenhouse should be assembled by two people. Particular care should be taken when handling glass and the wearing of gloves is strongly recommended. Favourable weather conditions should be chosen. Do not try to erect the building in windy conditions - the panels are difficult to handle in high winds.

All side frames should be suitably propped until the roof frames are secured.

Keep children and pets away until the work is finished.

Take your time - rushing causes accidents.

Fitting service

Please call your local dealer if you would like to have a quote for the erection of your greenhouse by an installer.

Tools required to erect the greenhouse

Drill & bits (for pilot holes), screwdrivers (for slot and posi-drive), spanners 10mm & 17mm, small hammer, pliers, spirit level, step ladder, tape measure, bradawl, mastic gun, saw & props.

Planning and preparation

All of the illustrations relate to a 8'/2.43m long Traditional Greenhouse. For other models you will have a greater or smaller number of Side and Roof Sections for your chosen model.

Before you commence assembly of the frame it is advisable to pre-determine the layout of individual sections to ensure the roof vents are in the position you require. Double roof sections must be positioned above double side sections, and single roof sections above single side sections.

If you **do not** wish to cut one of the roof cover strips please avoid positioning a roof vent at the very end of the greenhouse.

A bradawl should be used to pilot all screw holes, especially on the shelving and staging, to help prevent the timber from splitting. Sometimes the pre-drilled holes in the frames can be blocked - simply insert a screwdriver to clear them.

Unpacking the greenhouse

Before removing all the packaging please note the individual named pieces of greenhouse. This is not only a convenient way to check you have all the correct sections, but also to help you when determining the layout and assembly of your greenhouse. You will also notice all fixtures, nails, screws, bolts etc., come pre-packed and labelled for your convenience.

If using a knife be careful not to cut into the wood.

The plain gable end and the door gable end have carrying straps (pieces of timber) fixed to them and these **should not** be removed until after the greenhouse has been bolted together.

The door gable end also has a transit strap nailed to the bottom of the door posts which must be removed as soon as this section is unwrapped.



OPTIONAL ACCESSORIES

Get even more out of greenhouse

Alton have a range of accessories which will add extra benefits to your new Traditional greenhouse.

Many of the accessories can be brought when ordering your greenhouse - but may also be added at a later date.

If it is a possibility that any of the accessories will be added at a later date, due care and attention should be given at this stage to where the greenhouse is situated. eg space for extension to either end!

Louvre Vents

Extra side ventilation at staging height. Use in conjunction with roof and ventaccess promotes healthy air circulation. Can be used manually or with automatic openers.

To fix at a later date accessibility to both sides of the greenhouse is essential.

Extension Modules

Simply extend your greenhouse - either or both ends - using a pre-treated extension module(s).

You remove an end gable, bolt in the new extension, then replace the end panel.

When siting the original greenhouse, consider the space available for an extension at a later date.

Further Information

If you require further information on any of these Alton accessories please, in the first instant, contact your local Alton Stockist.

Cladding

Alton Cladding is an 'instant fit' cedar wood cladding which simply clips over the outside of the greenhouse. Clad to staging height gives maximum heat retention in winter and extra shade in the summer.



Accessibility all around the greenhouse is essential, to be able to fit and remove the cladding. Cladding can be brought and fitted to any side or sides you wish.

Rainwater Adaptor Kit

An easy to fit adaptor kit to connect both sides of the guttering and to take the rainwater to one single point. Ideal for collecting rainwater - and within easy reach to water the greenhouse plants!

Automatic Vent Openers

Just set and forget. These units automatically open and close in response to climatic conditions. Can be used on roof or side louvre vents to give optimum ventilation.

If this is not feasible, then please contact Alton Greenhouses direct, address details are on the back cover.

Siting your greenhouse

You may have already considered the position of your new greenhouse and be aware of the general guidance given. But it may be advisable to consider the following advice.

A flat level site is essential and further information on the preparation of the ground is given opposite.

It is necessary to leave sufficient working room around your greenhouse when you're putting it up and also to allow for the possible need to replace a piece of glass in the future. If possible try and leave a space of 2ft/610mm around the greenhouse.

Locate the greenhouse where there is maximum amount of sunlight and avoid if possible any shade from trees, fences or other buildings. Over-hanging branches can be a particular nuisance and should be avoided.

Choose a site where the greenhouse is relatively easy to get to and convenient to bring water to and possibly a supply of electricity.

Finally, and most importantly, choose a site where your Alton Greenhouse will look right so that it will complement your garden.

Site Preparation

It is essential that the concrete base kerbs are laid on firm level ground that is unlikely to let the greenhouse sink into it after a number of years. If the site for the greenhouse is not firm, level or well drained, it is advisable to lay concrete footings as illustrated, or lay a perimeter row of paving slabs. The depth of footings will depend on the nature of the ground on your site. For practical purposes a spade's width and depth may be preferred.

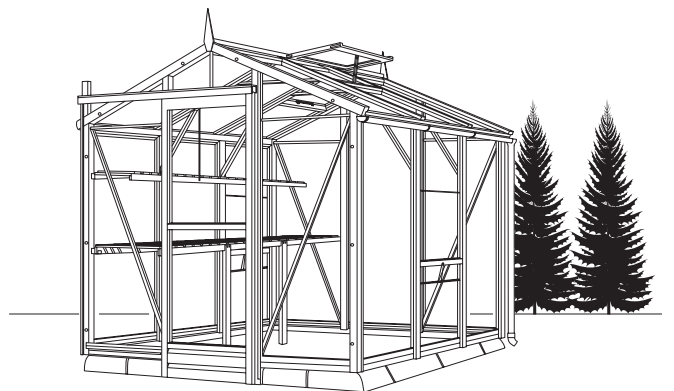
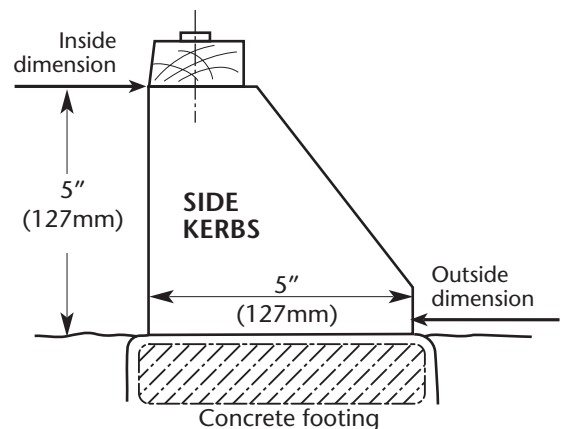
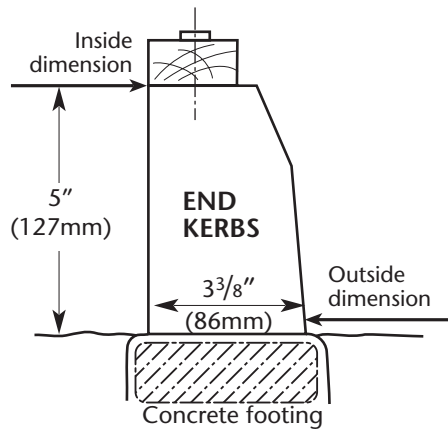



CONCRETE BASE KERBS

Base kerb dimensions

Model	INTERNAL DIMENSIONS			EXTERNAL DIMENSIONS		
	Width	Length	Diagonal	Width	Length	Diagonal
6'5" x 5'6"	5'10" (1778mm)	4'9" (1448mm)	7' 6 ¹ / ₄ " (2293mm)	6'8" (2032mm)	5'3 ³ / ₄ " (1619mm)	8'6 ¹ / ₄ " (2598mm)
6'5" x 8'0"	5'10" (1778mm)	7'3 ³ / ₈ " (2226mm)	9'4 ¹ / ₈ " (2849mm)	6'8" (2032mm)	7'10 ³ / ₈ " (2397mm)	10'3 ³ / ₄ " (3142mm)
6'5" x 10'6"	5'10" (1778mm)	9'9 ¹ / ₂ " (2984mm)	11'4 ³ / ₄ " (3474mm)	6'8" (2032mm)	10'4 ¹ / ₄ " (3156mm)	12'3 ³ / ₄ " (3754mm)
6'5" x 13'0"	5'10" (1778mm)	12'4 ¹ / ₈ " (3762mm)	13'7 ⁷ / ₈ " (4161mm)	6'8" (2032mm)	12'10 ⁷ / ₈ " (3934mm)	14'6 ³ / ₈ " (4428mm)
6'5" x 15'7"	5'10" (1778mm)	14'10" (4521mm)	15'11 ¹ / ₄ " (4858mm)	6'8" (2032mm)	15'4 ³ / ₄ " (4693mm)	16'9 ³ / ₈ " (5114mm)
6'5" x 18'0"	5'10" (1778mm)	17'4 ⁵ / ₈ " (5299mm)	18'4" (5589mm)	6'8" (2032mm)	17'11 ³ / ₈ " (5471mm)	19'1 ³ / ₄ " (5836mm)
6'5" x 20'7"	5'10" (1778mm)	19'10 ¹ / ₂ " (6058mm)	20'8 ⁵ / ₈ " (6314mm)	6'8" (2032mm)	20'5 ¹ / ₄ " (6229mm)	21'6" (6552mm)

Setting out the Concrete Kerbs

The kerbs should be laid out according to the internal dimensions for your particular model. The dimensions are given above. Check the diagonal measurements both ways to ensure squareness.

As a result of the manufacturing process the kerbs can in some cases be uneven on the underside and may need to be bedded on a dry sand/cement mix to correct any inaccuracy.

Each kerb has a number stamped on it to help you identify it and relates to the plan below. The plan

shows the position of each kerb. The ends are the same for all models but the number of kerbs (Ref S756) for the sides varies with the particular length of model. The example layout below is for a 6'5" x 8'/1.95 x 2.43m model. The corner kerbs should be positioned with the sloping side at the side of the the greenhouse and the vertical side to the front or back.

Please note that gaps between the concrete kerbs are normal and these should be grouted after erection of the greenhouse has been completed.

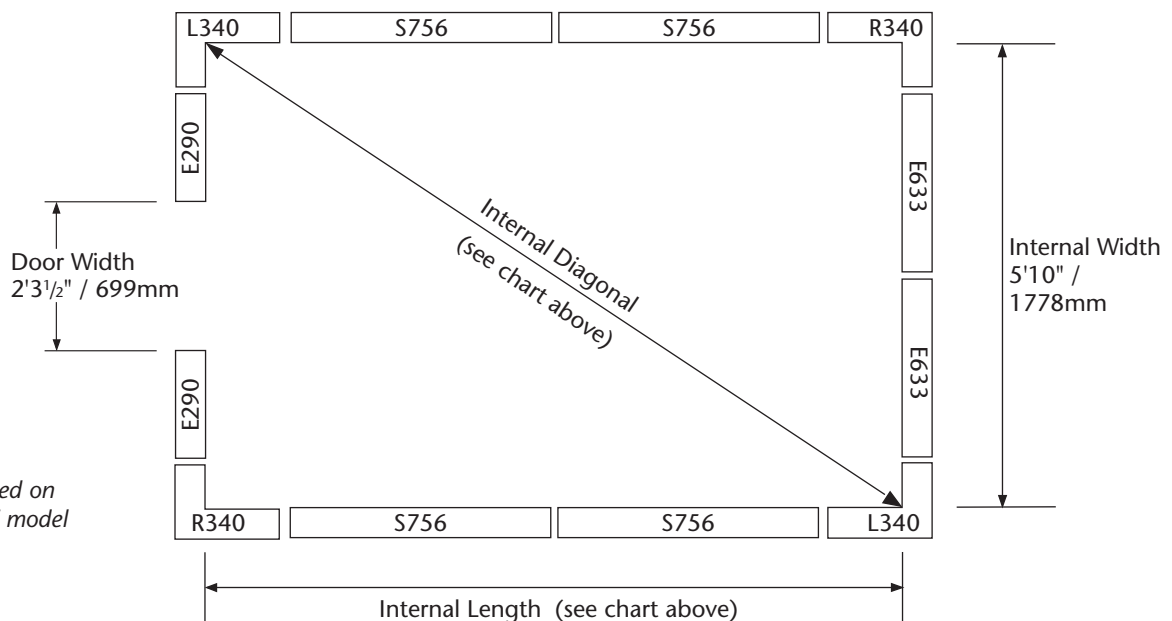
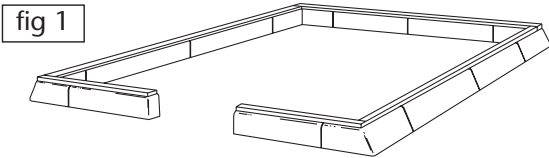

Diagram based on the 6'5" x 8' model

Fixing of cills to concrete kerbs



Layout the wooden cills in position making sure the side cills bevelled edge faces **inwards** from the building. There is no bevel on the gable end cills. They should be positioned with the slots closest to the outside.

Loosely fix the cills with the M10 x 50 coach screws (50mm long) and washers. Use the slots for any adjustment. See fig 2.

The kerbs have a plastic insert, which does have a different thread to that of the coach screws. This is not a problem, as the screws will make a new thread once you start to tighten the screws down.

When all in position tighten the screws down with a 17mm spanner.

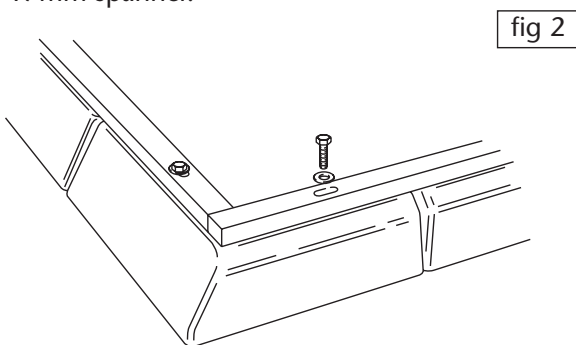

Prior to commencing the assembly of the sides gather together all the necessary bolts, washers, nuts, brackets & screws that you see identified below. The quantity will vary depending on the length of the model.

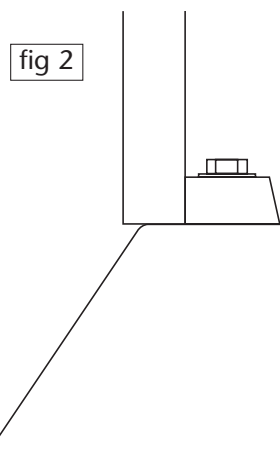
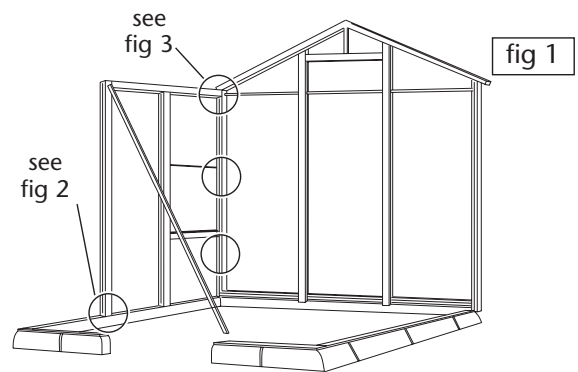

It's best to start with the plain gable end and side panel as shown in fig 1. Offer the end and side section to the cill being sure to rest both sections on the top edge of the concrete and against the outside edge of the cill. See fig 2.

Fix the sections together with 3 off 3³/₈" / 85mm bolts, washers and nuts as shown in fig 3. (Page 8) It's a good idea to prop the side section safely. See fig 1.

Fixing end Gable and the first side panel

The bolts for fixing the frames are different lengths and are for specific locations. Washers should always be fitted before the nut is put on. Please note that, when a low level vent is fitted adjacent to the gable end, the bolts have to be reversed and plastic caps are provided to cover the exposed nuts and bolt heads on the outside of the gable end.

Secure each section to the cill with a 2" / 50mm screw through each pre-drilled hole at the bottom of the section. See fig 6 on page 9.

Next fix a side section to the other side of the gable. In this situation the side vent is adjacent to the gable and the bolt must be reversed so it's head is inside the channel of the lift up vent.

Fixing the first side panel (cont.)

See fig 4. Use 3 off 2³/₄" / 70mm bolts, washers and nuts plus 3 plastic nut covers.

The lift up vent will require the transit blocks to be removed to give access to all the fixing holes. Check the glass slides up and down without hitting the bolt heads.

Note: It is correct that the end of the side section does not line up flush with the gable end.

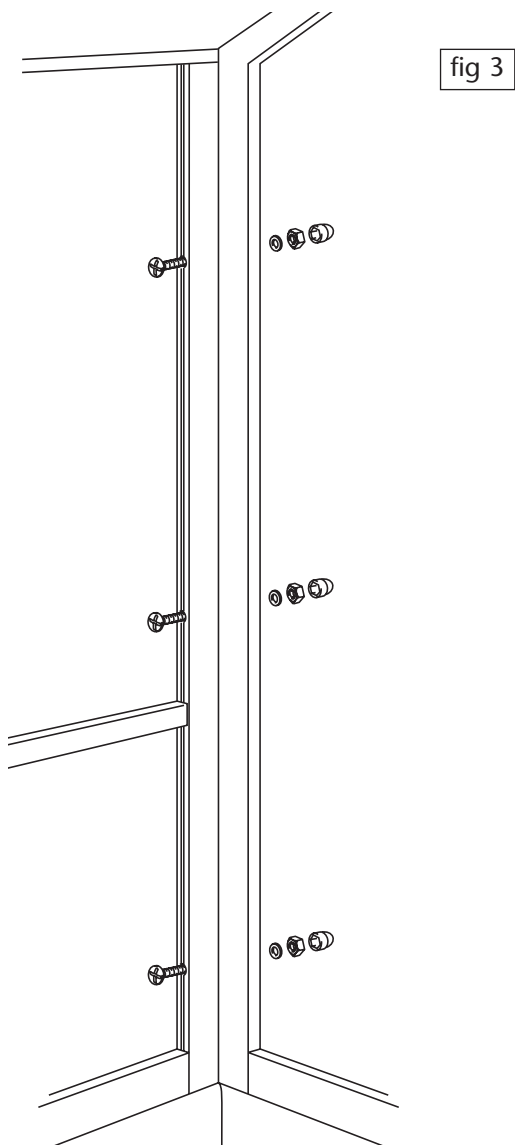

Fixing the remaining side panels

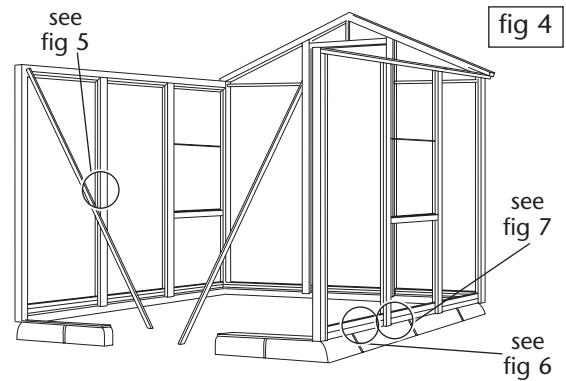

Repeat the same procedures for fitting the remaining side sections in place. Where side sections meet each other use the shorter 2³/₈" / 60mm bolts and fix with a washer and nut as shown in fig. 5 Remember to ensure the bolt head is inside the channel of the lift up vent.

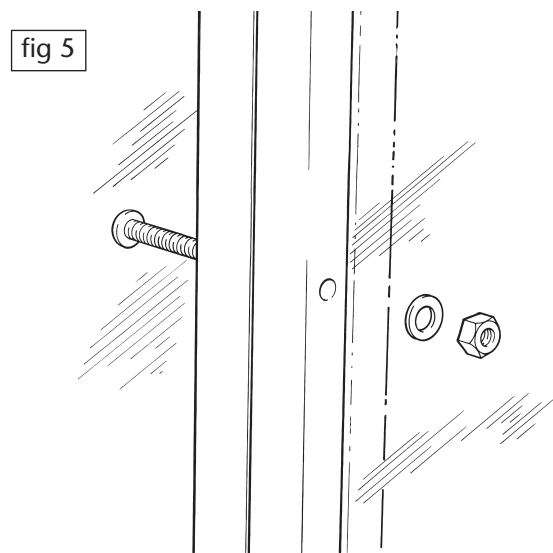

Continue to prop the sides as you progress.

Remember to fix the panels to the cills as before with a 2" / 50mm countersunk screw through each hole as shown in fig 6 on page 9.

Fixing the remaining side panels (cont.)

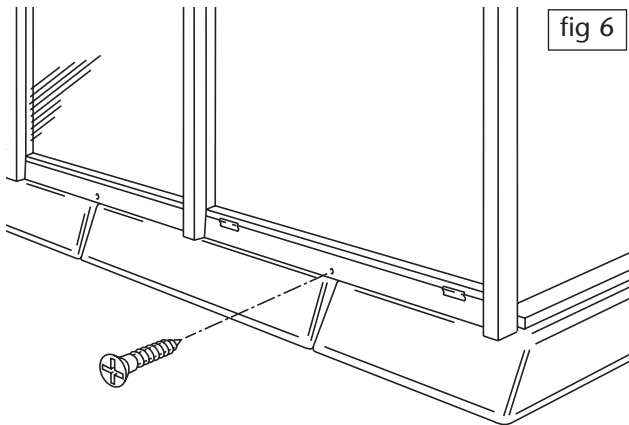

Fix the plastic tongue in the slot between the side panels. This may be done from either the top or bottom. See fig 7. Bend the plastic tongue over on itself when you push the end into the slot. This will prevent it from sliding back out. You may find it easier to accomplish this by gripping the folded end with a pair of pliers.

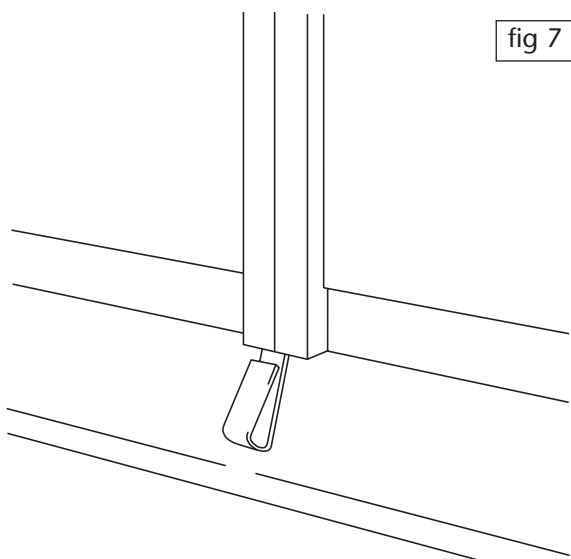

Fixing Door End Gable

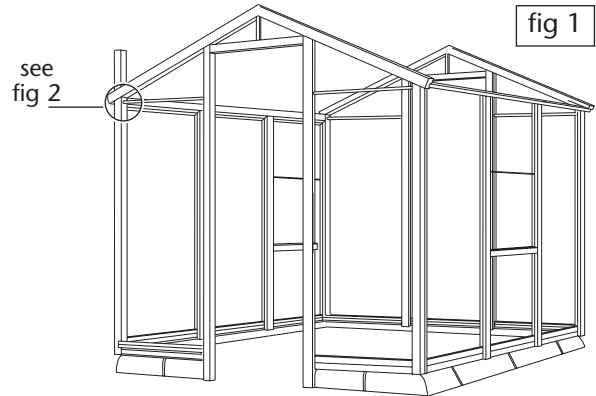

Having fixed all the side sections, offer the door gable to the assembly. Fasten the door gable end with 6 off $3\frac{3}{8}$ "/85 mm bolts, washers and nuts through the pre-drilled holes.

See fig 2.

Fix the door gable end to the cills with 2" / 50mm countersunk screws through each pre-drilled hole.

If the side vent is next to the door gable the bolts must be reversed. Use 3 off $2\frac{3}{4}$ "/70mm bolts, washers and nuts plus the plastic covers.

Plastic nut covers are only supplied for use on exterior nuts

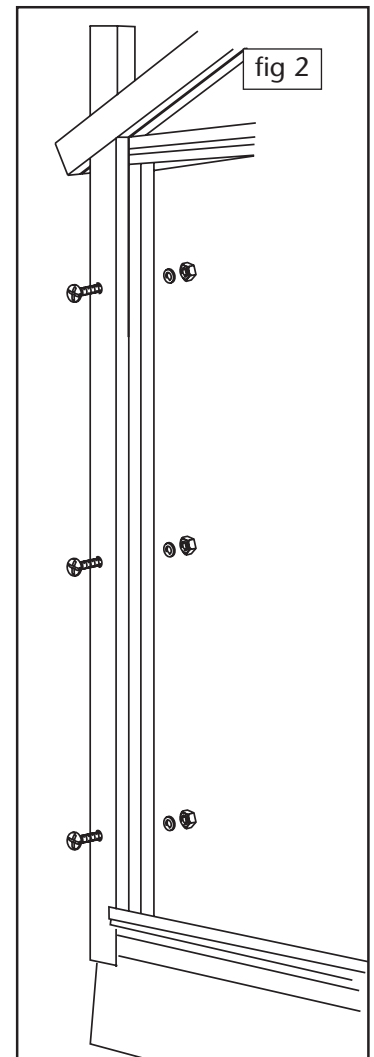

Preparation and Fixing of Ridge Bar

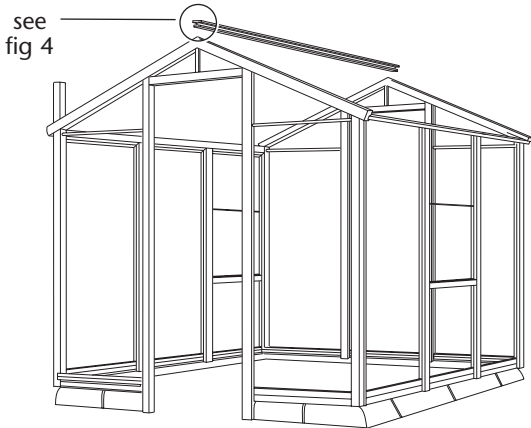

On all models mark the positions of the "U" shaped ridge brackets on the underside of the ridge bar. Position the brackets, with even spaces between them, so they coincide with the centre of each glazed roof section, half way between glazing bars.

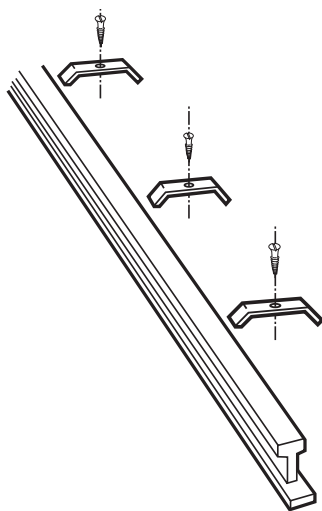

Illus. A

Drill pilot holes **and fix the brackets loosely** with $1\frac{1}{4}$ "/32mm screws. The number of brackets varies with the length of greenhouse.

Sealing mastic can be applied to the ridge when its fixed in position or now while it's still on the ground. A Mastic Gun is required and the nozzle should be cut to provide a $\frac{5}{8}$ "/15mm bead which is applied to the inside top edge of the ridge bar. See fig 3.

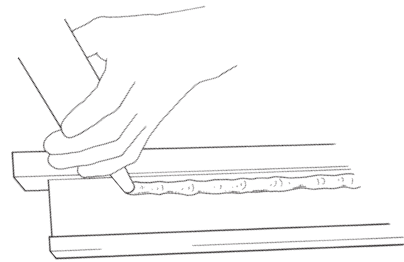

fig 3

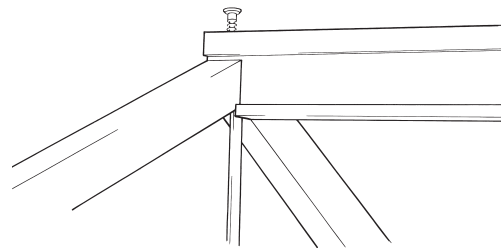

fig 4

With assistance, offer the ridge bar to the assembly and fix with a $2\frac{1}{2}$ "/64mm counter-sunk screw at each end. See fig 4.

On any ridge board longer than 8'0" it is essential to prop it at the centre for the duration of the assembly.

It is beneficial on the longer buildings to prop the ridge to the extent that it has a small upward curve in it.

On models over 13'/3.96m the ridge may be supplied in sections. Lay them upside down on level ground and join them by butting together the halved ends and securing them with the metal channel which is fixed with 4 off $1\frac{1}{2}$ "/38mm countersunk screws.

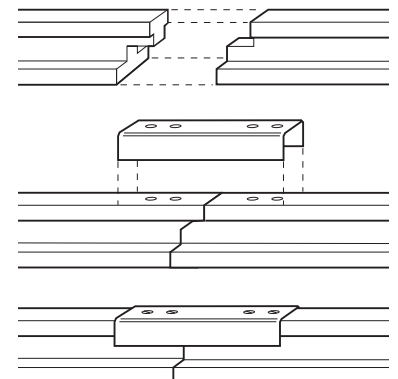

On all models mark the positions of the "U" shaped ridge brackets.

Fixing Roof Panels

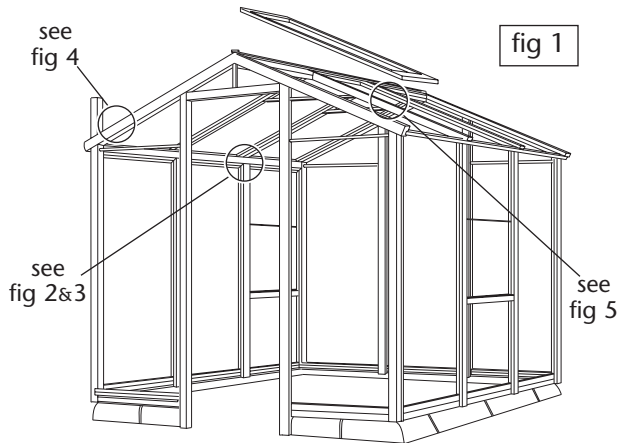

Prior to commencing the assembly of the roof gather together all the necessary bolts, washers, nuts, brackets and screws that you require for this part of the assembly.

- 1"/25mm Round head screws
- 3³/₈" / 85mm Bolts, washers and nuts
- 1¹/₂" / 38mm Countersunk screws
- 2" / 50mm Countersunk screws
- 2³/₄" / 70mm Bolts, washers and nuts
- Roof vent nails · Plastic tongue · Eaves brackets

The quantity will vary dependent on the length of the model.

Double roof sections must be positioned above double side sections, and single roof sections above single side sections.

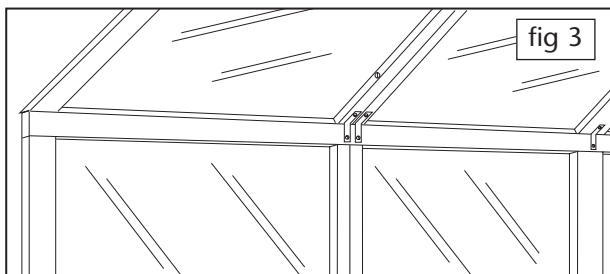
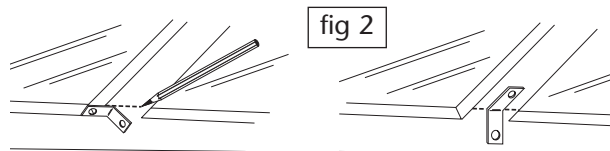

First fix the eaves brackets to the roof sections. They are required on each roof section except where adjacent to the gable ends. See fig 2. Refer to fig 3 and position the bracket so it's lined up with the inside edge of the eaves rail of the roof section and mark along the upper edge of the bracket. Position the bracket in the centre of the style and line up the bend with the mark. Secure each bracket to the roof section with a 1"/25mm round head screw.

Offer up the first roof panel. Align with holes in the gable end by inserting a screwdriver through the holes. Fix the gable end to the roof panel

by inserting 3³/₈" / 85mm bolts from the outside through each hole. Fit washer and nut on the inside. See fig 4.

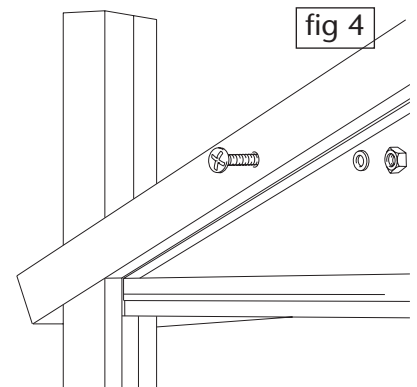

Fix the other end of the eaves bracket with a 1"/25mm round head screw into the top of the side panel.

Now repeat the above with the roof panel on the opposite side of the greenhouse.

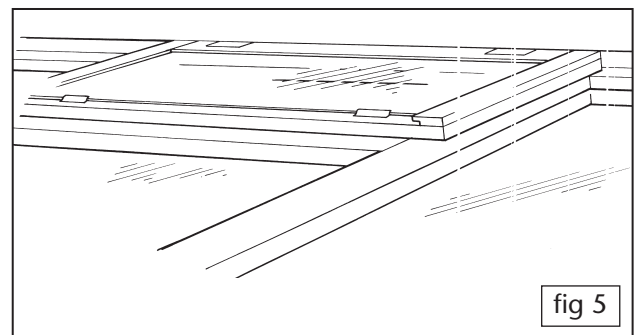

Fixing roof panels (cont.)

When they are both in place with all bolts and screws fitted you can tighten the screws holding the ridge bracket to the ridge. **Before fully tightening ensure the roof panels are pushed tight up against the ridge.**

Position the roof vent centrally and secure with 3 off 2"/50mm countersunk screws through the pre-drilled holes. See Fig 5.

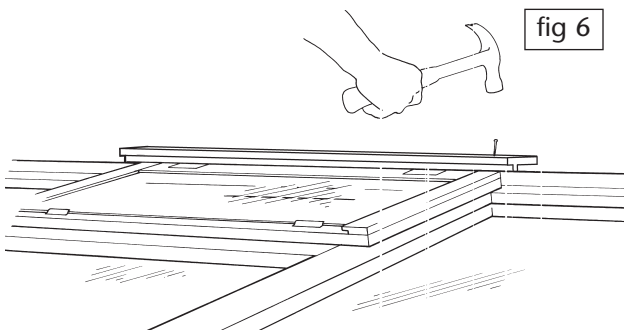

Now fit the roof vent cap above the vent. Fit the vent cap with the drip rail side above the vent and the other side flush to the edge of the ridge. See fig 6 for reference and secure with nails from the roof vent kit.

If you have roof vents adjacent (either side) to each other you will have to trim the vent caps as detailed in fig 7.

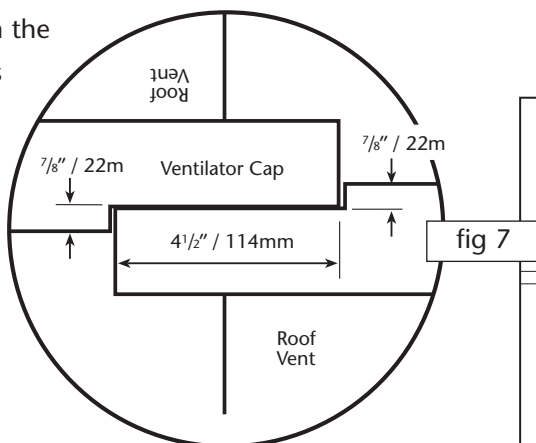

Leave the casement fittings or automatic openers until later.

Follow the same procedures for fitting the remaining roof sections in place.

Where roof sections meet each other use the shorter 2³/₄"/70mm bolts and fix with a washer and nut. Fit any other roof vents and vent caps.

Fix the plastic tongue in the slot between the two roof panels. See fig 8. Bend the plastic tongue over on itself when you push the end into the slot. This will prevent it from sliding back out and you may find it easier to accomplish this by gripping the folded end with a pair of pliers.

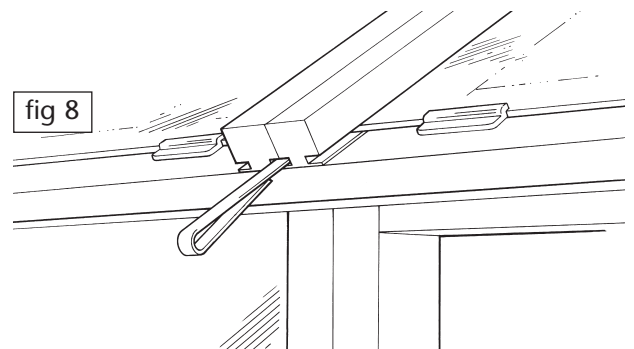

Note: It is correct that the end of the roof section does not line up flush with the gable end.

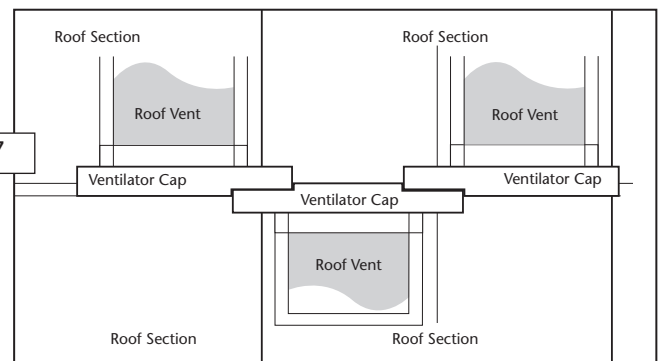

Fixing the Roof Fascias and Finials

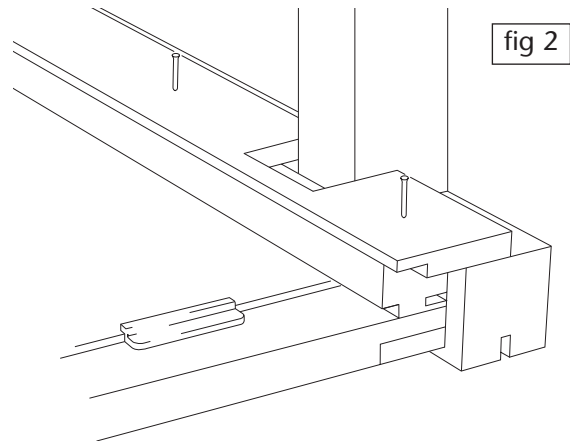
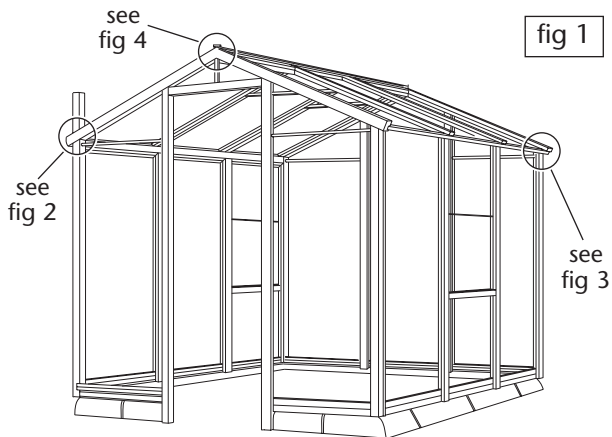

The gable roof cover strips (4) should be fitted next. At the door end you will need to cut out the necessary gap for the door post. Offer up the strip to mark off the correct amount to be carefully cut out.

Then fix with 1"/ 25mm nails, use 5 per strip. See fig 2.

Fix the remaining roof cover strips as shown opposite in fig 3.

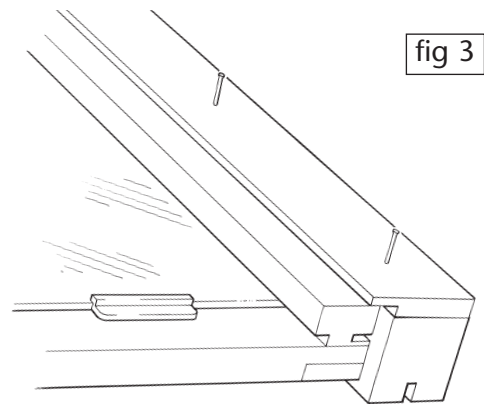

If you have a roof vent adjacent to the gable you will have to cut away part of the strip to allow the vent to close. Again offer it up into position to establish the amount you need to remove.

Attach the finials to each gable end with 2 off 1"/ 25mm nails each. See fig 4.

Now remove the transit bars from both gable ends.

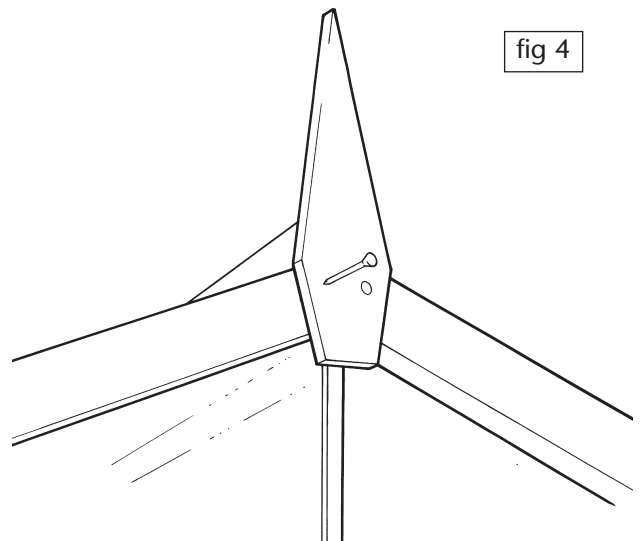

Bracing and Supports

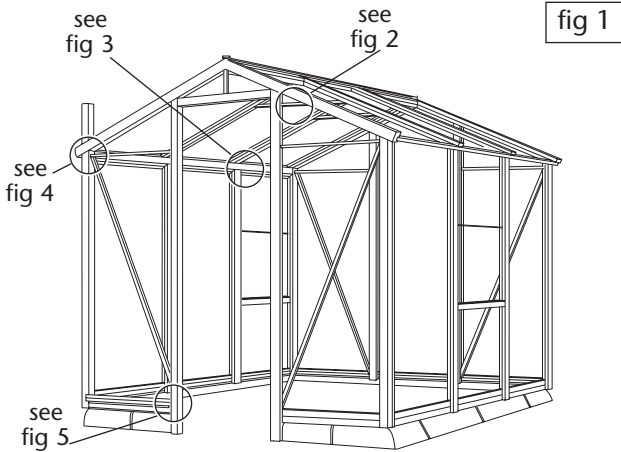

Fix the RIDGE braces to every glazing bar except at the gable ends. These are 2' / 610mm in length and should be positioned centrally and secured with 4 off 1 1/4" / 32mm countersunk screws for each. See fig 2.

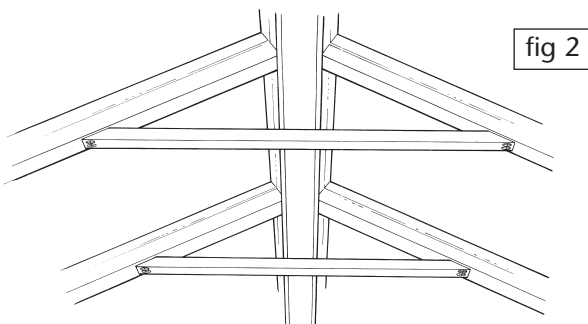

ON ALL MODELS fit the EAVES braces on every glazing bar except at the gable ends as shown in fig 3. These braces are 1'10" / 560mm in length and are secured by 4 off 1 1/4" / 32mm countersunk screws.

Measure a distance of 12 1/4" / 312mm down from the top of the side section to get the correct position of the end of each brace.

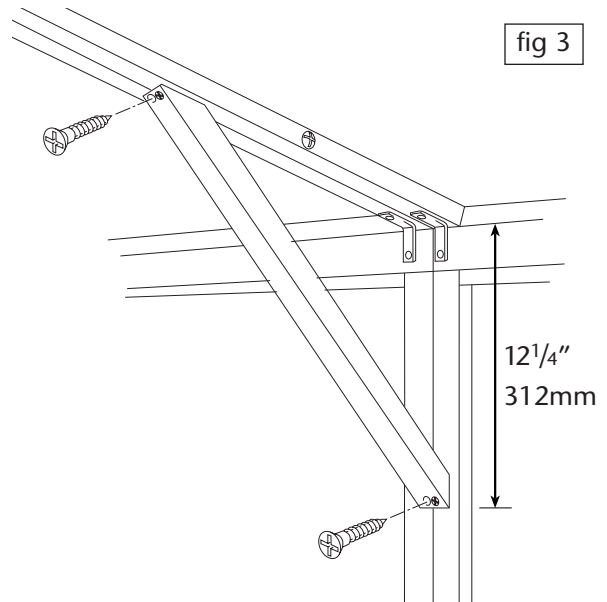

Gable end braces are fixed as shown in fig 4 & 5. Double check the verticals before securing with a 1 1/4" / 32mm countersunk screw at each end.

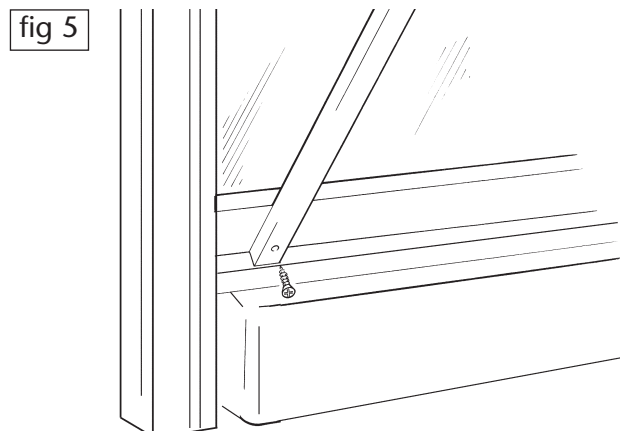
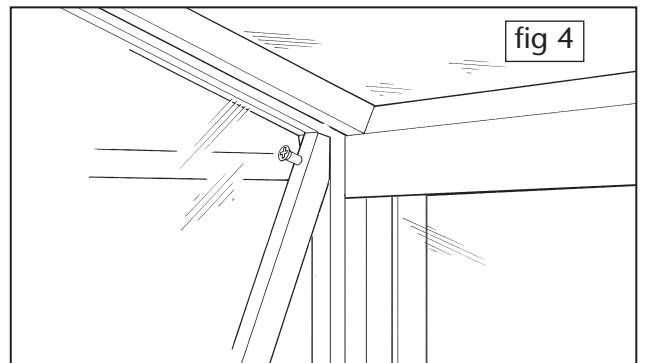

Fixing the Door

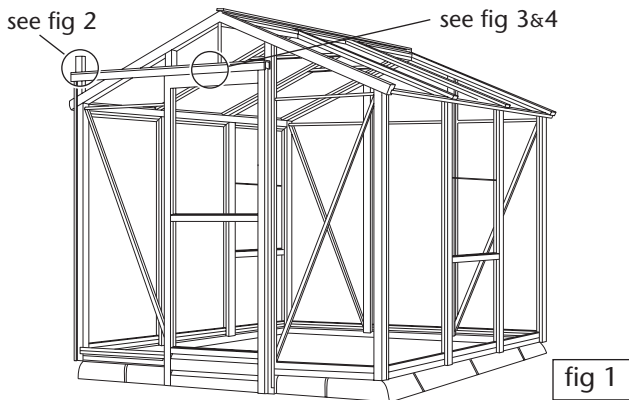

To help you get the correct clearance under the door it can help to lay the timber door stop (slamming strip) on the ground at the door entrance so the under side is level with the bottom of the kerbs. If you then stand the door on the strip this will give you clearance of about $\frac{3}{8}$ " / 10mm beneath the door.

Check with a spirit level that the door is vertical and then hold the metal top door track in position and mark its location on the frame.

Take the door away and fit the metal top door track. Ensure the right hand end lines up with the outside edge of the door post and fix with 4 off $1\frac{1}{2}$ " / 25mm countersunk screws as shown in fig 2.

Assemble the door pelmet with 6 off $1\frac{1}{2}$ " / 25mm) nails as shown in fig 3 being careful not to split the timber.

Secure the pelmet to the metal top door track using 4 off $\frac{1}{2}$ " / 12mm countersunk screws as in fig 4.

Slide the door into position on the door track.

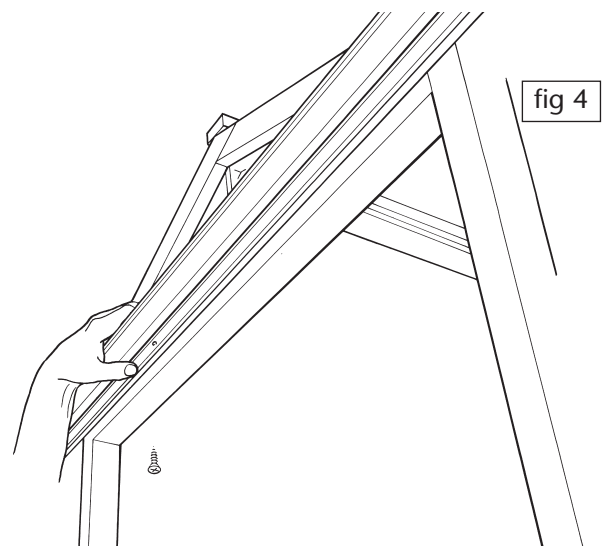
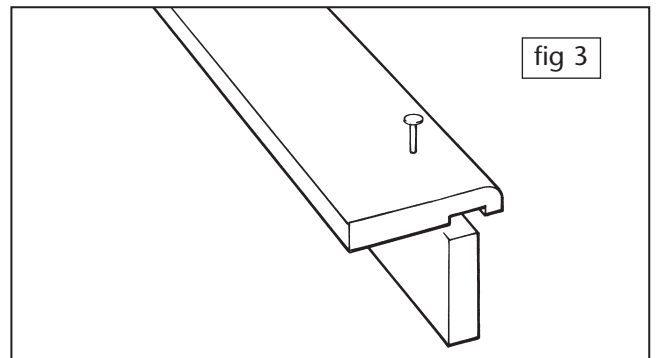
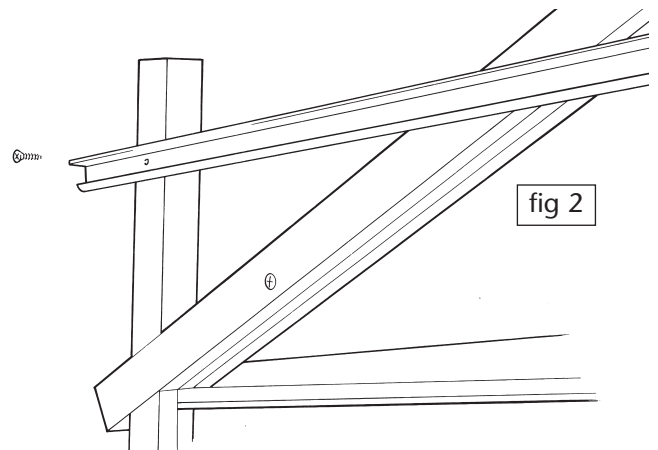

Fixing Door (cont.)

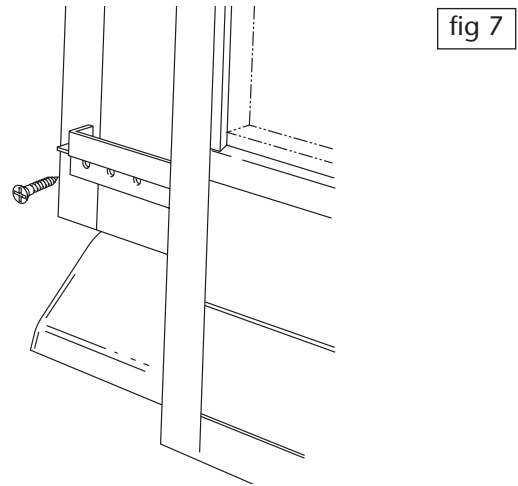
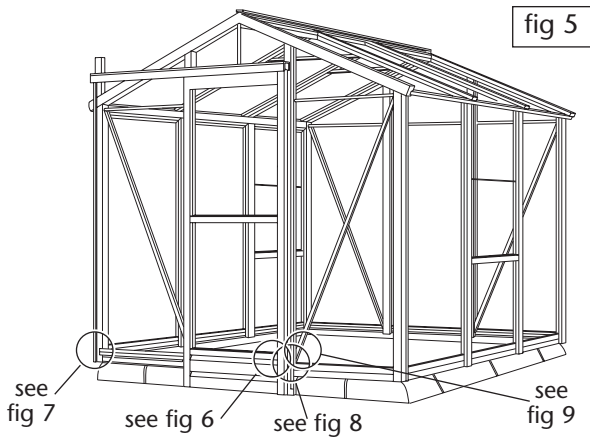

Positioning of the metal bottom door guide is important. The door must not rest on the guide, it must hang by the rollers in the top track and have a clearance between the door and the bottom guide rail. Fix into position with 2 off $\frac{3}{4}$ "/19mm countersunk screws. See fig 6 & 7.

Position the metal door stay as shown in fig 8 so that when the door is closed it lines up with and covers the end of the channel cut into the door.

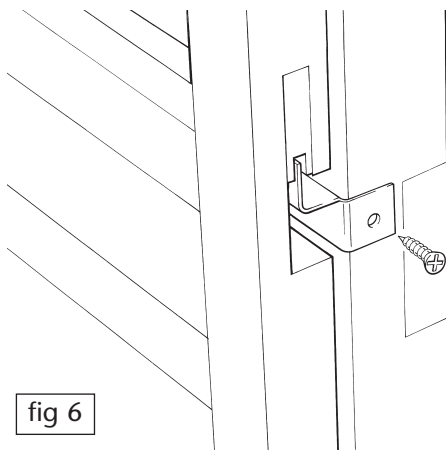

Fix with 2 off $\frac{3}{4}$ "/19mm countersunk screws.

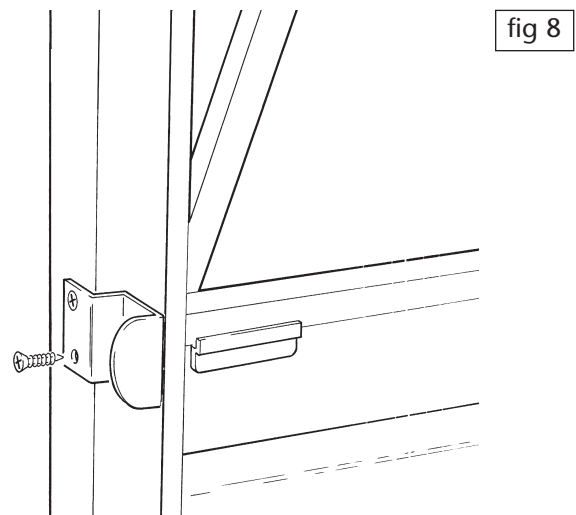

Shut the door to the metal door stop and then hold into position the timber door stop (slamming strip) so that it is flush to the door edge. See fig 9. Secure with 3 off $1\frac{1}{4}$ "/32mm countersunk screws, in the pre-drilled holes.

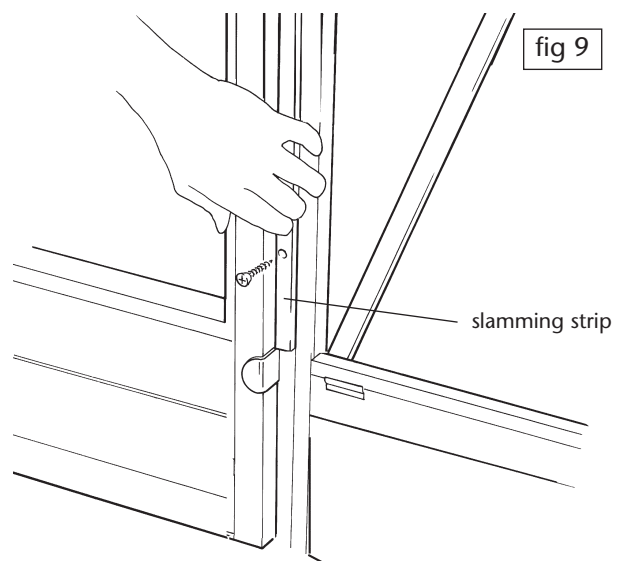

Louvre Vent Assembly and Fitting

Louvre vents are fitted at stage height and are positioned to complement other ventilation available: eg ventaccess and roof vents.

First, carefully remove existing sheet of glass from the chosen panel by removing the glazing strip and the two brown glass stops. Support the glass at the bottom, then gently remove the glass by initially moving to the left. Put safely to one side. Remove centre nut and bolt from side section.

good fit and make secure with brown glass stops and replacing the glazing strip. See fig.4.

Finally open louvre to the horizontal position and insert glass blades, (4mm thick). Secure by bending lips up. (Use pliers if necessary).

The fitting of automatic openers can be done at this stage. Please follow the instructions that come with the unit.

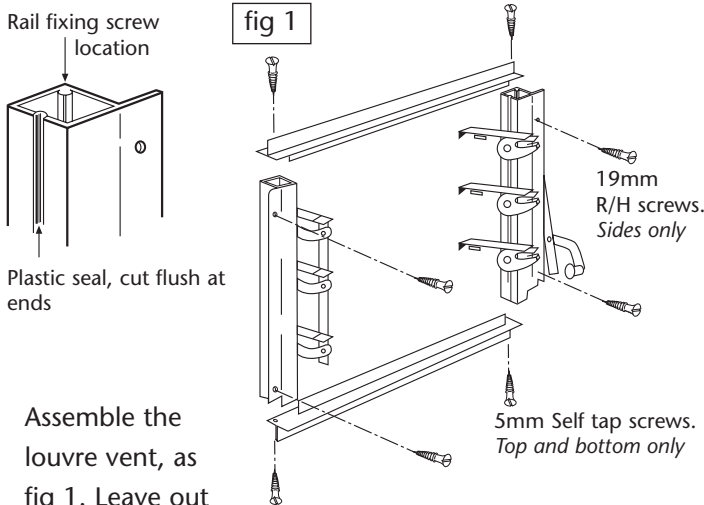
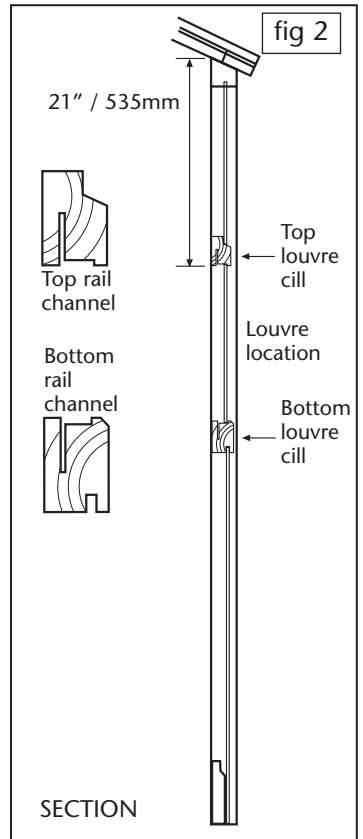

Assemble the louvre vent, as fig 1. Leave out the glass panels.

Measure 21"/535mm for top of panel. See fig 2. Insert the louvre top rail into the top cill channel until fully home. Together with the top sheet of glass (18¹/₂" x 28¹/₄" / 470 x 730mm) offer up to the section so that the bottom of the top louvre cill is at 21"/535mm. See fig 3. At this stage mark screw locations of vent, make pilot holes with bradawl/drill. Secure with 3/4" / 19mm roundhead screws provided.

Fit bottom cill onto the louvre vent bottom rail. Place bottom sheet of glass in position, pushing gently upwards to ensure a

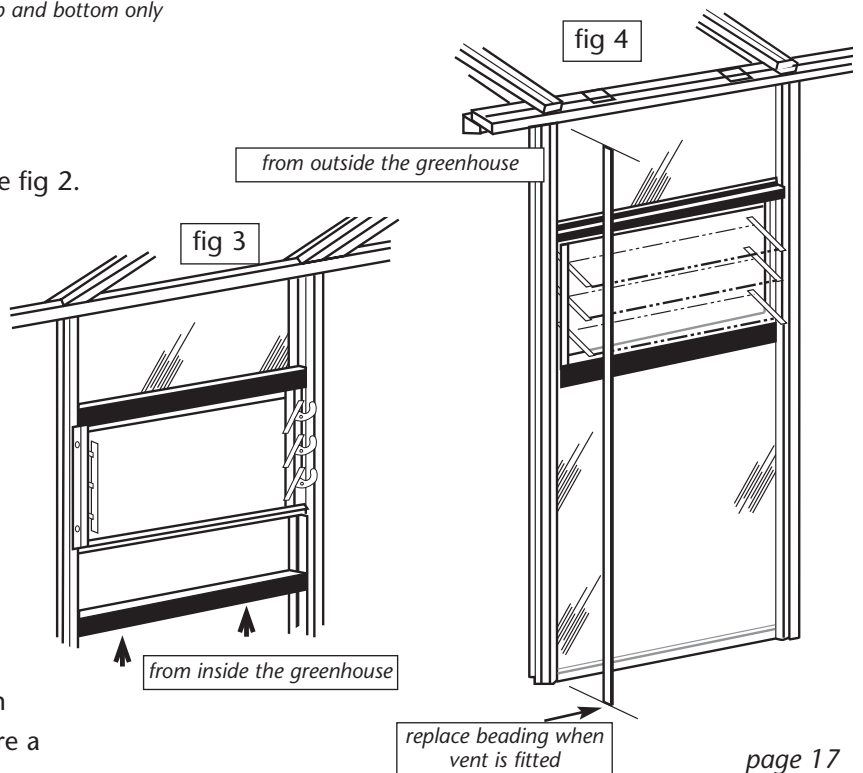

Ventilator Options

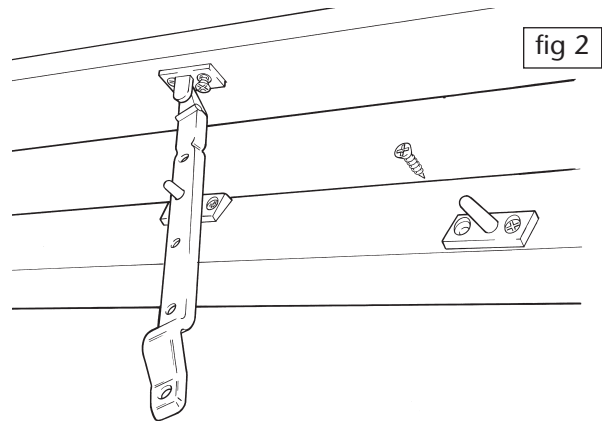
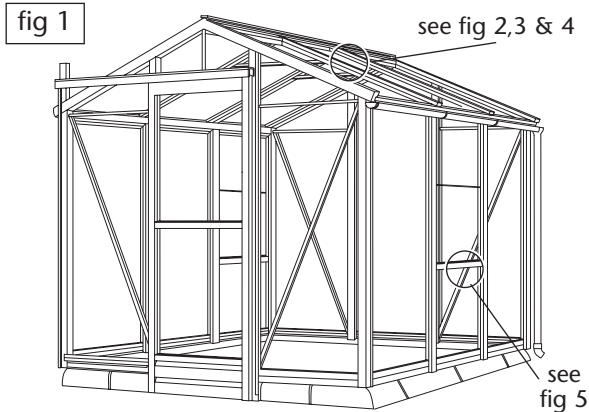

If you have not ordered an Automatic Opener as an optional extra we supply a casement stay for each roof vent.

With the roof vent closed fix the casement stay centrally to the roof vent with 2 off $\frac{3}{4}$ " / 19mm countersunk screws as shown in fig 2.

Locate the positions of the two studs with reference to the casement stay. Note the position of the 'offset stud' and the 'central stud' from fig 3. When your happy they are in the correct position fix with $\frac{3}{4}$ " / 19mm countersunk screws.

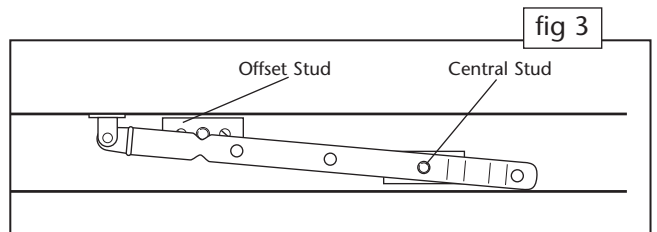

We do not supply a casement stay when an Automatic Opener is supplied.

Refer to fig 4 and fix a $1\frac{1}{4}$ " / 32mm round head screw centrally in the timber bar above each of the lift up side vents. Fit the spring to the vent handle and fit the handle to the clip.

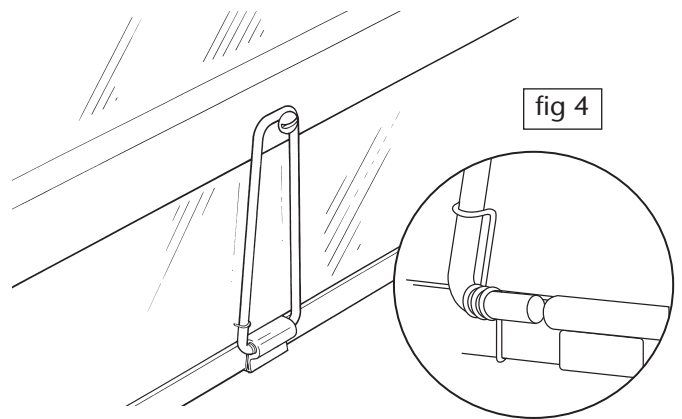

To fix an Automatic Opener refer to fig 5 plus the separate instructions supplied with the unit.

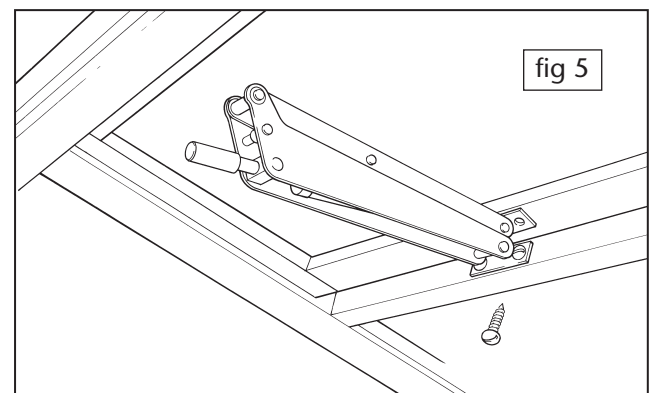

Gutter assembly and Fitting

Decide at which end the downpipes will be located. Use a length of string to give a fall of $\frac{1}{2}$ "/12mm over every 10' / 3.04m.

Fix the downpipe brackets into position with $\frac{3}{4}$ "/ 19mm countersunk screws and slide the downpipe into the brackets and fix loosely with the bolt & nut. See fig 2.

Drill a 5mm fixing hole in the stop end outlet, screw it into place with the downpipe connected. Using a $\frac{3}{4}$ " / 19mm screw. See fig 4.

Fix the support brackets fig 3 and joint bracket/s fig 5 as required for the length of greenhouse. Use $\frac{3}{4}$ " (19mm) screws. Working from the downpipe end fix the guttering into the brackets having trimmed it to length if necessary with a fine saw. The stop end should finish level with the gable end of the greenhouse.

Tighten up the downpipe and fix the shoe at the bottom. See fig 6.

Repeat the process on the other side.

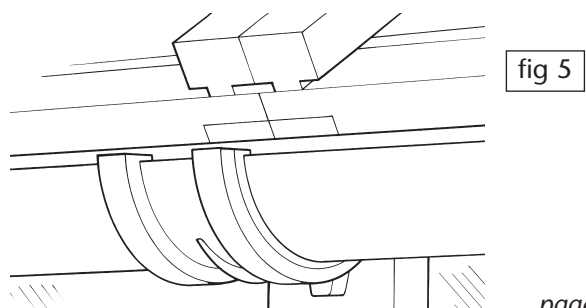
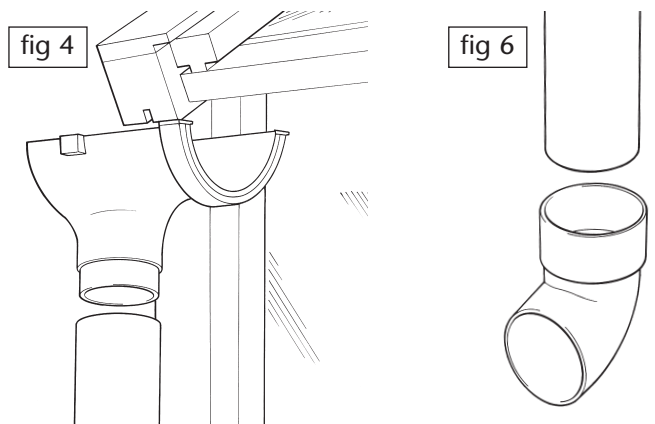
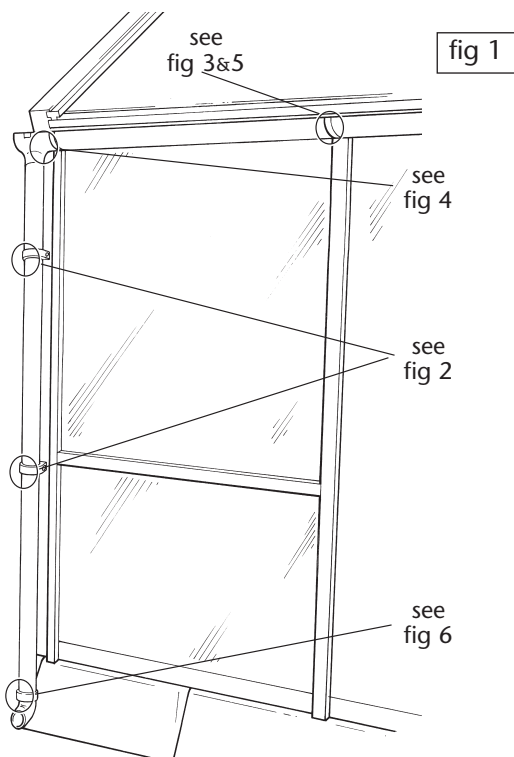
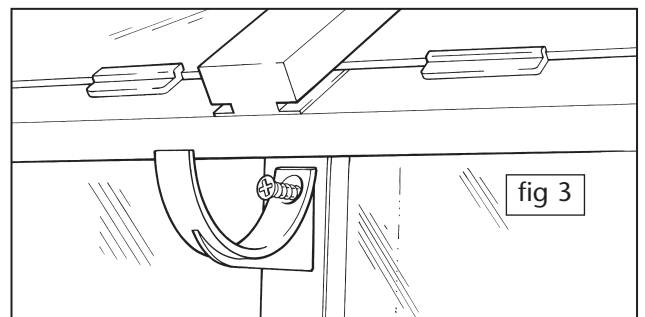
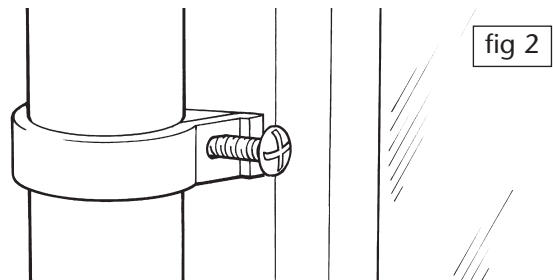

High Level Shelving

The high level shelving can be fitted to either side of the greenhouse.

To locate the brackets for the high level shelf measure $13\frac{1}{2}$ "/345mm down from the top of the side panel at each glazing bar and gable end. See fig 2.

This is the location of the screw hole for each bracket. Fix the brackets with $\frac{3}{4}$ "/19mm round head No 10 screws. See fig 3. The double bracket is used where the lengths of shelving meet.

Place the shelf on the brackets and position the shelf strap. After **drilling pilot holes** fix the bottom of the strap flush to the shelf bearer and fix the top to the roof glazing bar making sure the shelf is level. See fig 4. Screws for fixing are $\frac{3}{4}$ "/19mm round head No 10.

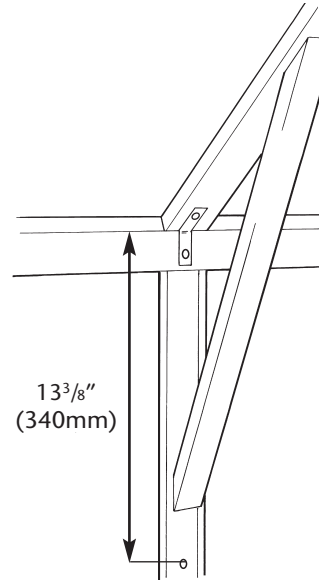

fig 2

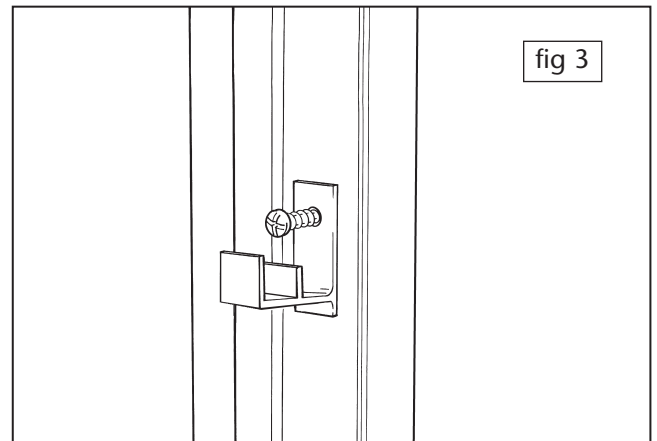

fig 3

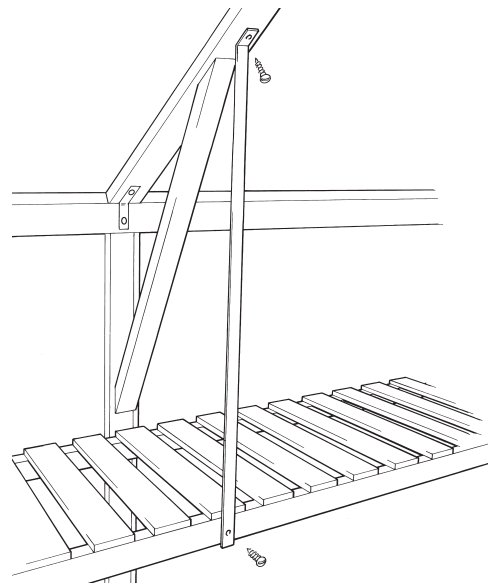
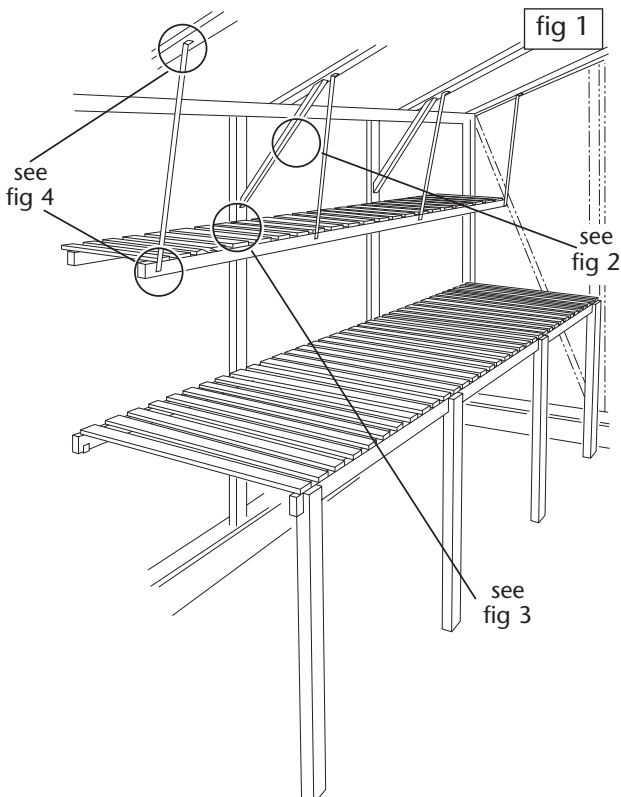

fig 4

Staging assembly

The staging can be fitted to either side of the greenhouse.

To get the staging support brackets at the correct height hold one of the staging legs next to each side glazing bar with the bottom of the leg level with the underside of the concrete base kerb and mark on the glazing bar the level of the rebate at the top of the leg.

This is the correct height for the horizontal part of the support brackets on which the staging frames rest. They are fixed with $\frac{3}{4}$ "/19mm round head screws. See fig 2.

The double bracket is used where the lengths of staging meet.

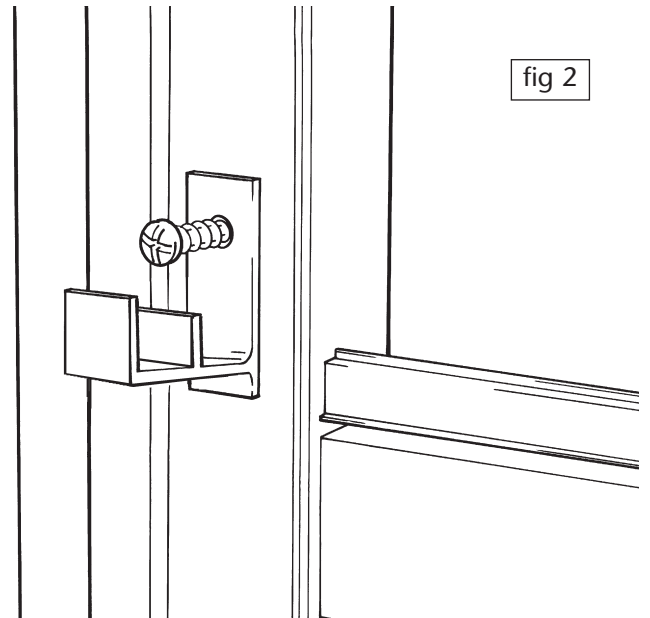

Position the staging legs as shown opposite and after **drilling pilot holes** fix in place with 1"/25mm countersunk screws.

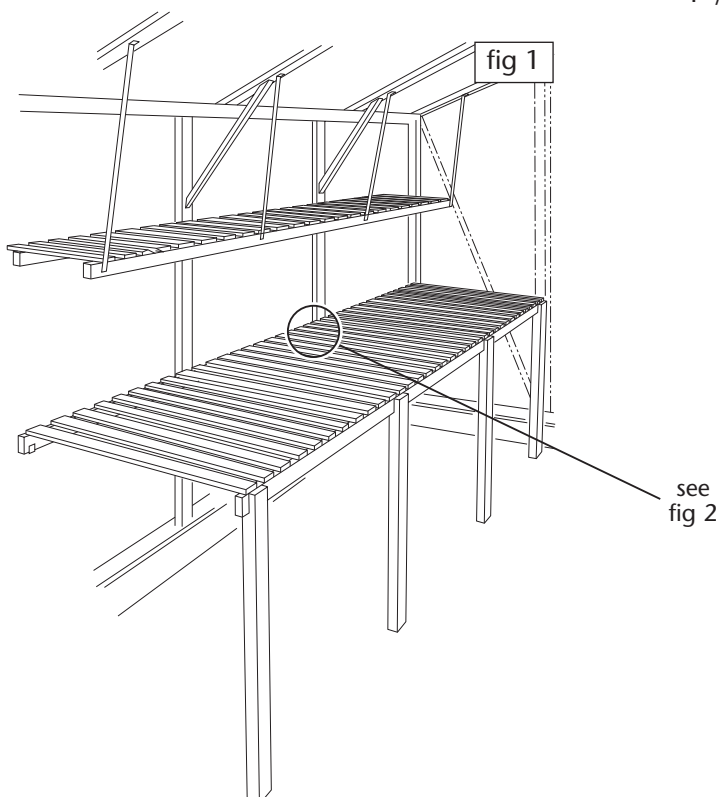

Glass Details

In the event that any glass is broken upon delivery we ask that you purchase the glass locally and forward us the bill for repayment. This will be the quickest way to rectify matters and get your greenhouse completed. The details give the sizes and method of fitting.

If you are not happy to do this or have any other difficulties please contact our After Sales Department on 01295 770291 during office hours. Please refer to the brown envelope attached to the delivery notes.

Replacing Glass

When handling glass please ensure you wear gloves.

Roof glass

All roof glass slides into glazing grooves and is held in place at the eaves with plastic glass stops which are fixed with screws.

Side and End glass

All glass is held in on one side by a glazing groove and on the other by a timber beading and plastic glass stops at the bottom. The timber beading can be prised off carefully with a wide putty knife and the plastic glass stops are fixed with screws.

Replacement glass should be slid into the glazing groove, and with the other side in the rebate it should be pushed upwards into the top glazing groove. The glass stops and beading should then be re-fixed.

Glass Sizes

We use 3mm horticultural glass as standard, 4mm toughened glass as an optional extra.

Door and Gable End glass

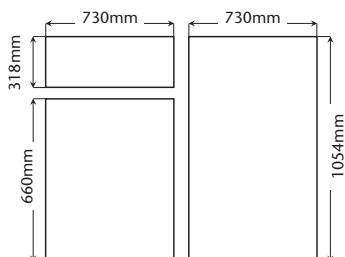
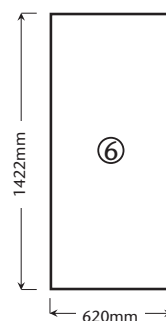
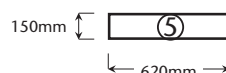
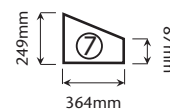
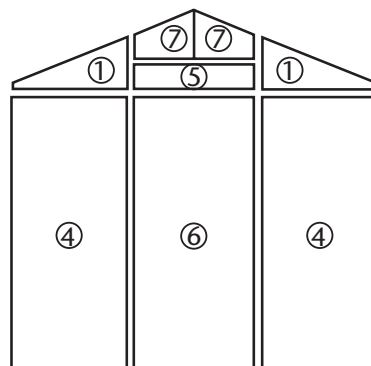
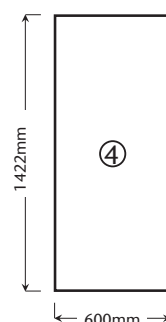
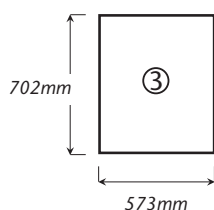
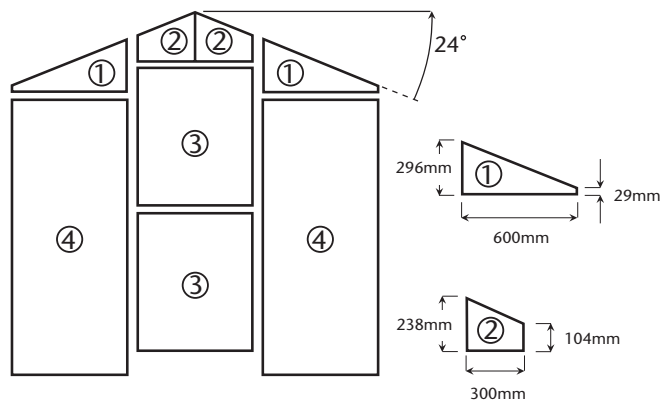

Roof Panel glass

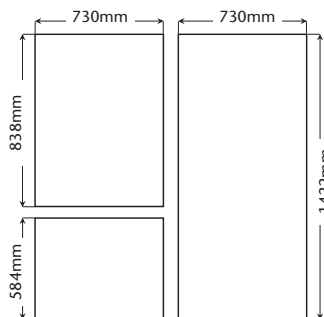

Side Panel glass



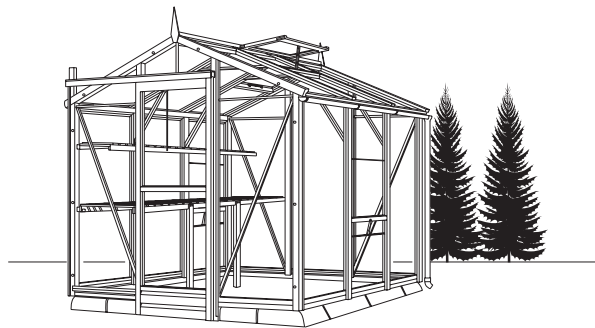

ALTON Greenhouses, Station Works, Fenny Compton, Southam, Warwickshire CV47 2XB
Telephone: 01295 770795 · Fax 01295 770819

08/04